

BLACK DIAMOND®

Project Name: _____

Location: _____

Item #: _____

Qty: _____

Black Diamond 2 Double Tap Towers Beer Dispenser, 32 Cu. Ft., in Black

USBD-9028/2



The Black Diamond 2 Double Tap Towers Beer Dispenser offers robust 32 Cu. Ft. storage for kegs, cans, and bottles, making it ideal for high-volume bar or restaurant environments. Durable plastic-coated steel doors, adjustable shelves, and an advanced side-mounted compressor ensure optimal performance and easy cleaning. Electronic controls, a wide 33° to 40°F range, and secure locking doors provide reliability and peace of mind, while a two-year parts and labor warranty and five-year compressor warranty deliver lasting value.

FEATURES AND CONSTRUCTION

- 32 Cu. Ft. capacity provides ample storage for kegs, cans, and bottles
- Side-mounted 1/3 HP compressor ensures efficient and uniform cooling
- Laminated black vinyl exterior and stainless steel interior offer superior durability and a sleek, professional finish
- Maintains a consistent internal temperature range from 33°F to 40°F for beverage quality preservation
- Three hinged, reversible doors feature recessed handles and secure locking mechanisms
- Four height-adjustable, plastic-coated wire shelves allow flexible configuration for bottles and cans
- Fixed base design without casters for stable and permanent placement in commercial settings
- Measures 90.4"W x 27.8"D x 35.6"H, offering substantial storage in a space-efficient footprint
- Integrated locks on all three doors for secure after-hours storage
- Dual stainless steel double tap towers and ability to hold four half-barrel kegs support versatile beverage service

ELECTRIC

115V / 60Hz / 1 ph

Cord Length (Inches): 110.20"

Plug Type: NEMA 5-15P

Cord set included

NEMA 5-15P



3RD PARTY APPROVALS



WARRANTY (USA / CANADA)

Two (2) Year Limited Warranty on Parts and Labor, Five (5) Year Warranty on Compressor and Evaporator

Contact us for details at 1.877.368.2797



STORAGE CAPACITY

- Cubic Feet: 32 Cu. Ft.
- Half Barrel Keg: 4
- 12 oz Cans: 152 6-pks, 12 oz Bottles: 165 6-pks

TEMPERATURE

- Holding Temperature (Fahrenheit): 33° - 40°

These models are designed to operate in an environment where temperature and humidity do not exceed 75°F (24°C) and 55% relative humidity



Black Diamond 2 Double Tap Towers Beer Dispenser

USBD-9028/2

FRONT

SIDE

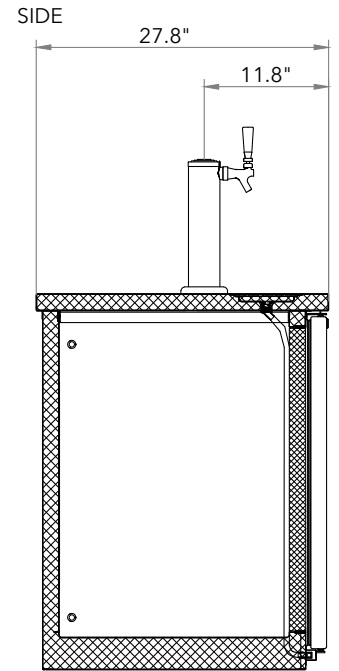
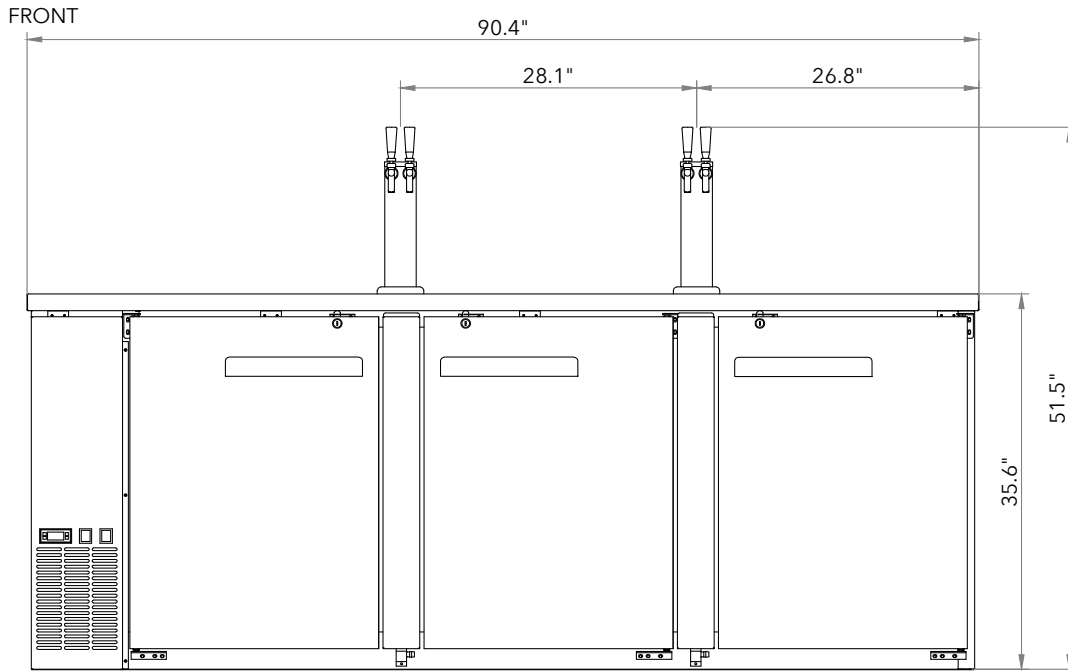

TOP

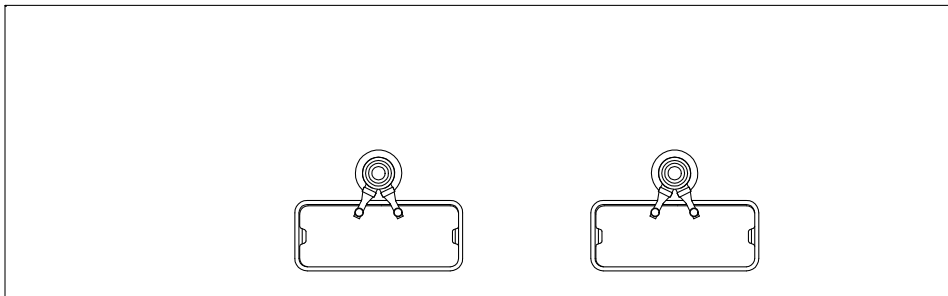

TOP

Beer Dispenser

Taps	Kegs (Half Barrels)	Doors	Shelves	Amps	HP	Refrigerant Type / Oz.	Assembled Dimensions (in)	Item Weight (lbs)	Shipping Weight (lbs)
4	4	3	4	7.5	1/3	R290 2.471	27.80" x 90.40" x 35.60"	363.8	407.0

Due to periodic changes in designs, methods, procedures, policies and regulations, the specifications contained in this document are subject to change without notice. While we exercise good faith efforts to provide information that is accurate, we are not responsible for errors or omissions in information provided or conclusions reached as a result of using the specifications. By using the information provided, the user assumes all risks in connection with such use.