

## 5.0 Gallon 90 mil LBR Pail with Tri-Seal Gasketless Cover

### Multiple Uses

Dry Products  
Liquid Products

### Product Codes

Container: **5500 Series, 55100**  
Description: 5.0 gallon 90 mil Pail

### Cover: 8500 Series

Description: Standard Tri-Seal Gasketless Cover  
Note: \*Multiple fitting and venting options available

### Features

Gauge: 90 mil.  
Nominal capacity: 5.0 USG / 19.0 L  
Stack performance: 350 lbs.\*  
Tare weights: Body: 2.08 lbs. / .948 kgs  
Cover: .73 lbs. / .331 kgs.

Note: \*Ratings will be reduced with uneven load distribution.

### Specifications with Cover

Dimensions: 12-3/8" D X 14-11/16"H  
Maximum capacity: 5.36 USG / 21.2 L  
Tare weight: 2.81 lbs. / 1.27 kgs.

### Colors

Standard: White, Black and Natural  
Custom: Available at manufacturer's discretion

### Decorating Options

Four color offset printing  
Print area: 33"W x 8-1/2"H  
Sleeve or pressure sensitive labeling

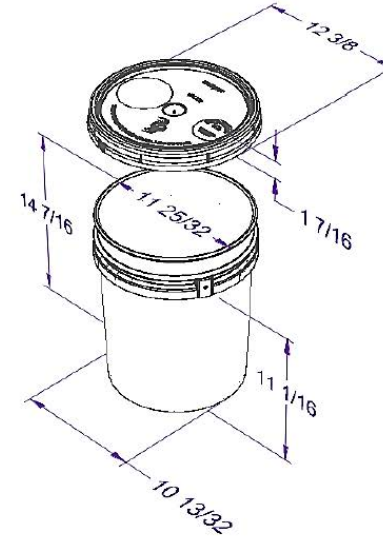

### Shipping Data

Qty. per pallet/carton:  
Gross Weight (lbs./kgs.)\*\*:  
Length (in./cm.):  
Width (in./cm.):  
Height (in./cm.):

### Bodies

240\*  
499 / 226  
48 / 122  
36.5 / 91.4  
45 / 114

### Covers

1,200\*  
876 / 397  
48 / 122  
40 / 101.6  
98 / 249

### Filled Containers

36 (12 per layer / 3 layers high)  
Pallet Height: 48"

Estimated truckload quantity of 5,520 bodies and covers\*\*\*

Notes: \*Quantity can vary based on customer request  
\*\*Weight does not include pallet/packaging  
\*\*\*Truckload quantity based on 53' trailer

### Materials

FDA approved materials  
Resin: Body: High-Density Polyethylene (HDPE)  
Cover: High-Density Polyethylene (HDPE)

### Optional Carrying Handle

Wire or Plastic

### DISCLAIMER

THIS INFORMATION IS PROVIDED AS A GENERAL GUIDE, INCLUDING DIMENSIONS. IT IS THE CUSTOMER'S RESPONSIBILITIES TO SELECT THE PROPER CONTAINER FOR PRODUCT AND APPLICATION COMPATIBILITY.

DISTRIBUTED BY:



DESCRIPTION:

3.5-7 gallon HDPE Cover

REF NO.:

DWG20639