

- NOTES:**
1. SCALE: 1:1
 2. FINISH: M28SP400 WITH RAMPS
 3. MATERIAL: HDPE
 4. GRAM WT.: 54 GRAMS
 5. OVERFLOW CAPACITY: 990 ± 15 (32 FL. OZ. NET)
 6. STANDARD S.P.I. TOLERANCES APPLY TO ALL BODY DIMENSIONS.

TOP

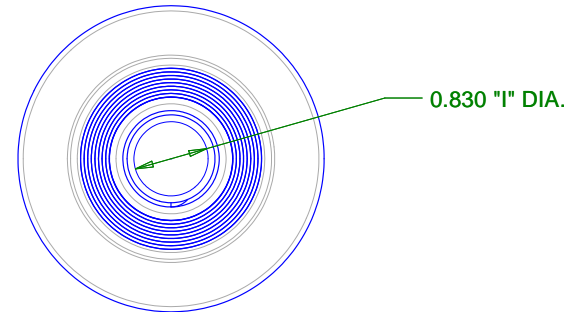

BOTTOM

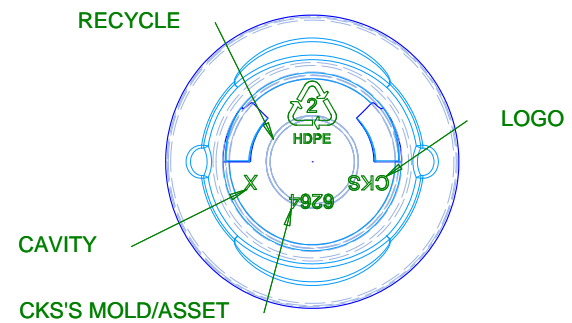

DISCLAIMER

THIS INFORMATION IS PROVIDED AS A GENERAL GUIDE, INCLUDING DIMENSIONS. IT IS THE CUSTOMER'S RESPONSIBILITIES TO SELECT THE PROPER CONTAINER FOR PRODUCT AND APPLICATION COMPATIBILITY.

DISTRIBUTED BY:



REF NO.:

DWG30390

DESCRIPTION:

32 oz HDPE Ring Decanter, 28-400