

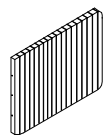

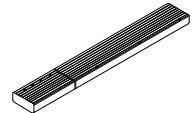

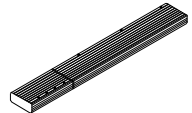

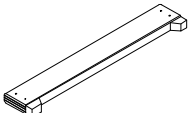

ASSEMBLY INSTRUCTION

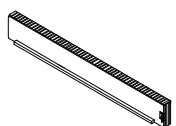
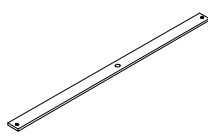
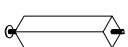
1547F-1 / 1547F-1(SPK) FULL BED
1547-1 / 1547-1(SPK) QUEEN BED

A Headboard  1 pc	B H/B Poster Left  1 pc	C H/B Poster Right  1 pc	D Footboard  1 pc
E Side Rail Left  1 pc	F Side Rail Right  1 pc	G Slat  4 pcs	H Support Leg  4 pcs
I Allen Bolt $\text{Ø}5/16" \times 45\text{mm}$  16 pcs	J Allen Bolt $\text{Ø}5/16" \times 63\text{mm}$  6 pcs	K Spring Washer $\text{Ø}5/16"$  22 pcs	L Flat Washer $\text{Ø}5/16" \times 19\text{mm}$  22 pcs
M Screw $\text{Ø}8 \times 30\text{mm}$  8 pcs	N Allen Key 4mm  1 pc	O Rectangle Plate $220 \times 80 \times 3\text{mm}$  2 pcs	

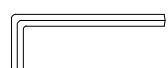
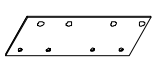
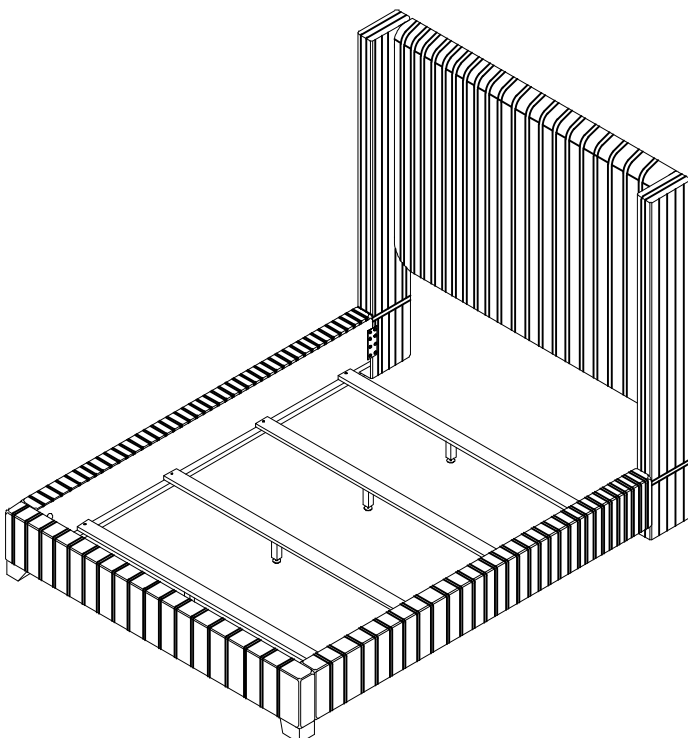

This page lists all the contents included in the box. Please take the time to identify the hardware as well as the individual components to this product. As you unpack and prepare for assembly, place the contents on a carpeted or padded area to protect them from damage.

IMPORTANT NOTE:

1. Do not tighten all screws / bolts until all completely assembled.
2. Keep all hardware parts out of reach of children.

***** Do not tighten screws & bolts until the entire unit is completely assembled.**

1

Attach H/B Poster Left & Right (B), (C) to Headboard (A) by using Allen Bolt (J), Spring Washer (K) and Flat Washer (L), tightening with Allen Key (N).

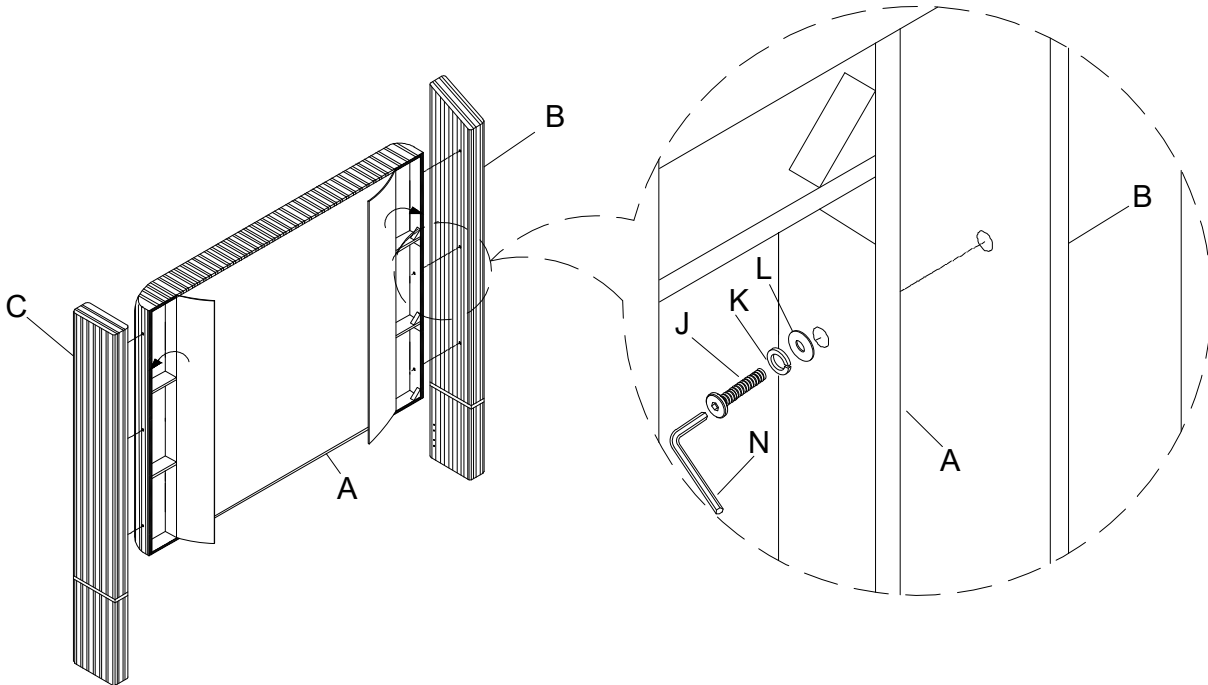

2

Attach Rectangle Plate (O) to the Side Rail Left & Right (E), (F) and H/B Poster Left & Right (B), (C) of Headboard (A) by using Allen Bolt (I), Spring Washer (K) and Flat Washer (L) with Allen Key (N). Unfasten bolts on Footboard (D), then attach Side Rail Left & Right (E), (F) to Footboard (D) and tighten all bolts with Allen Key (N).

Remark: Do not tighten the bolts until screw Slat (G) well on the Side Rail Left & Right (E), (F).

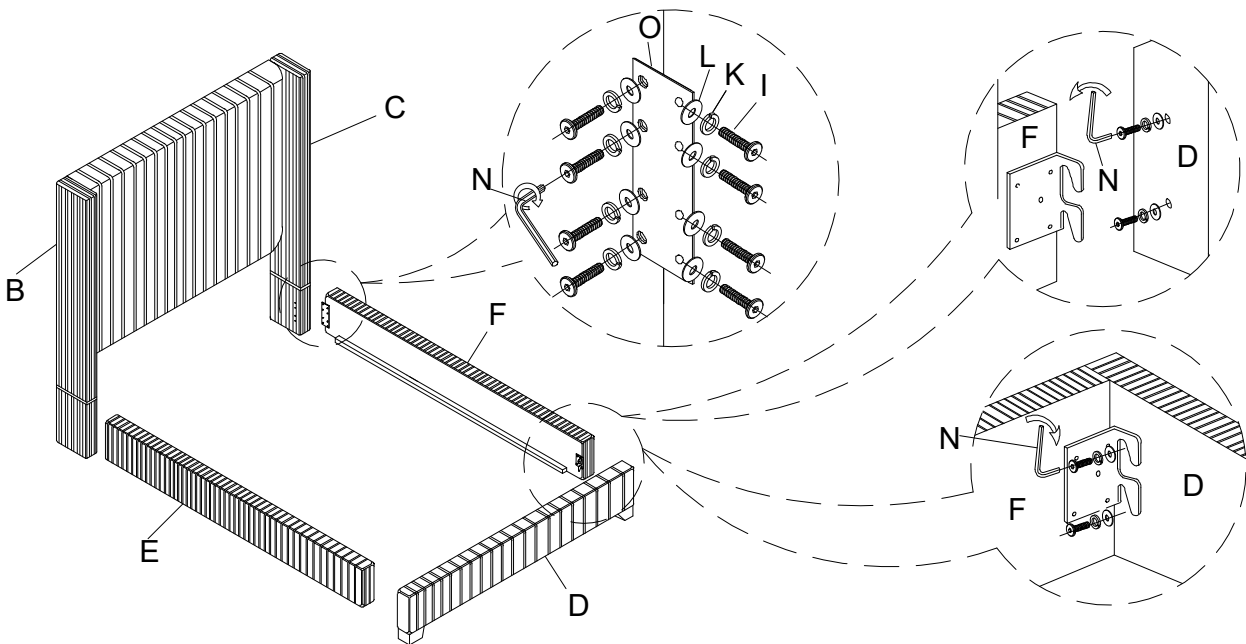

***** Do not tighten screws & bolts until the entire unit is completely assembled.**

3 Attach Support Leg (H) to Slat (G).

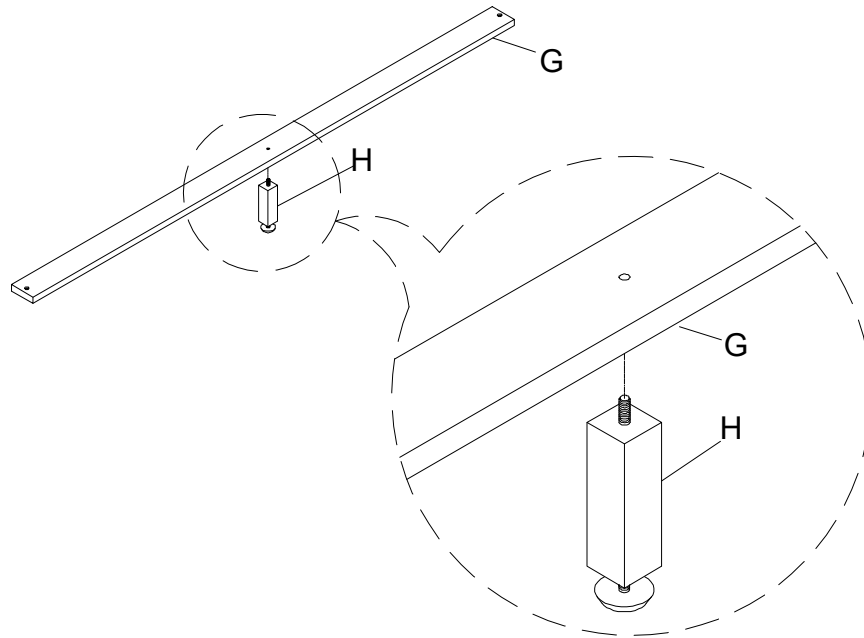

4 Attach Slat (G) to Side Rail Left & Right (E), (F) by using Screw (M) and Screw Driver (not included). Remark: Tighten the bolts after screw Slat (G) well on the Side Rail Left & Right (E), (F).

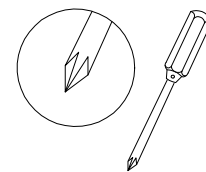
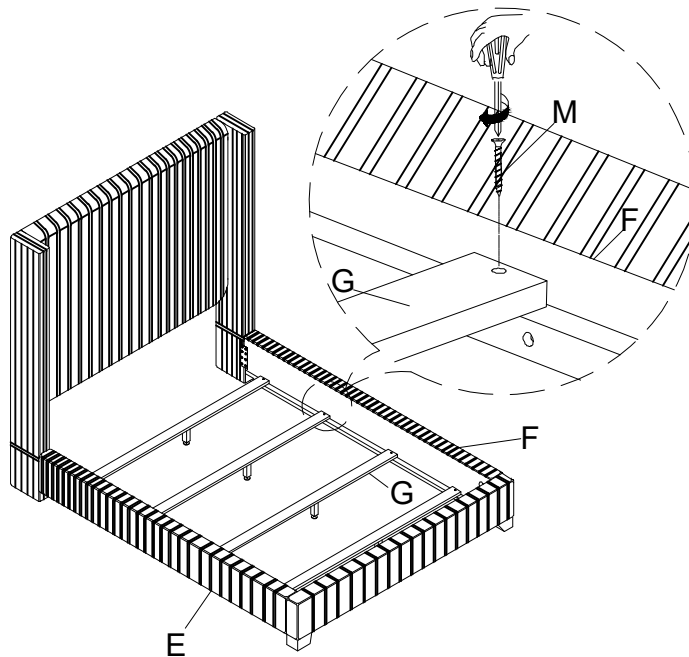

Phillips head screwdriver (not included) is required for assembly. Use the Phillips head screwdriver to tighten the screws.

Cleaning & Care

Treat surface with care. Surface is resistant to scratches but is not scratch resistant. Clean surfaces with a dry or damp soft cloth. Do not use abrasive cleaners. Hardware may loosen over time. Periodically check that all connections are tight.