

Installation Instructions for Trilock Eclipse Dummy

Suits 35mm to 45mm door thickness

Step 1

- Fold template where indicated.
- Position template on door edge at desired height, align with operating Eclipse on opposite door.
- Firmly hold template and mark 4 off 10mm holes centres & 1 off 54mm hole centre.
- Drill pilot holes [suggested size 3mm (1/8")]. Then enlarge holes as per template, drilling from both sides of the door.

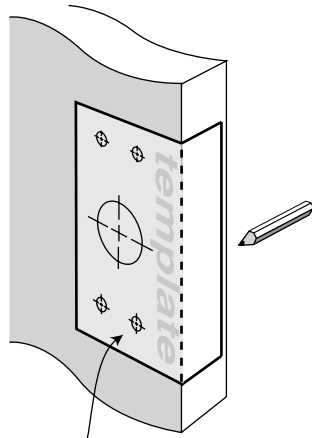

Please note: Ensure the template position and orientation is as shown, incorrect installation voids warranty.

Step 2

- Install 4 off M4 threaded posts to Eclipse external faceplate

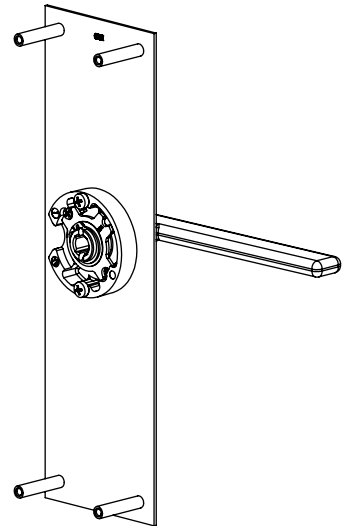

Step 3

To rehand external lever & set lever operation (if required).

- To rehand, remove the stop screw and rotate the lever 180° and refit the stop screw.

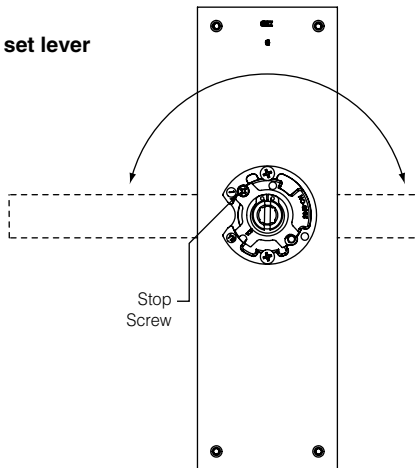

Step 4

- Fit 4 off mounting screws from inside into threaded posts.
- Align both face plates to door edge & each other and tighten screws.

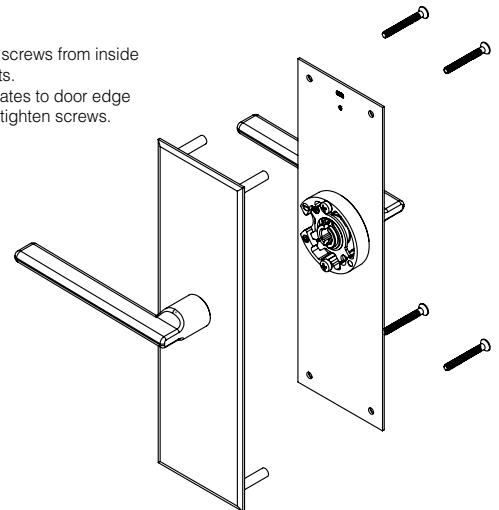

NOTE:

- carefully follow these instructions when installing.
- do not overtighten screws.
- use of power driver is not recommended.
- fully remove the Trilock prior to painting the door to avoid harming the product's finish.

Gainsborough

TRILOCK 

BY GAINSBOROUGH

Installation Instructions for Trilock Eclipse Dummy

Suits 35mm to 45mm door thickness

Exploded Diagram

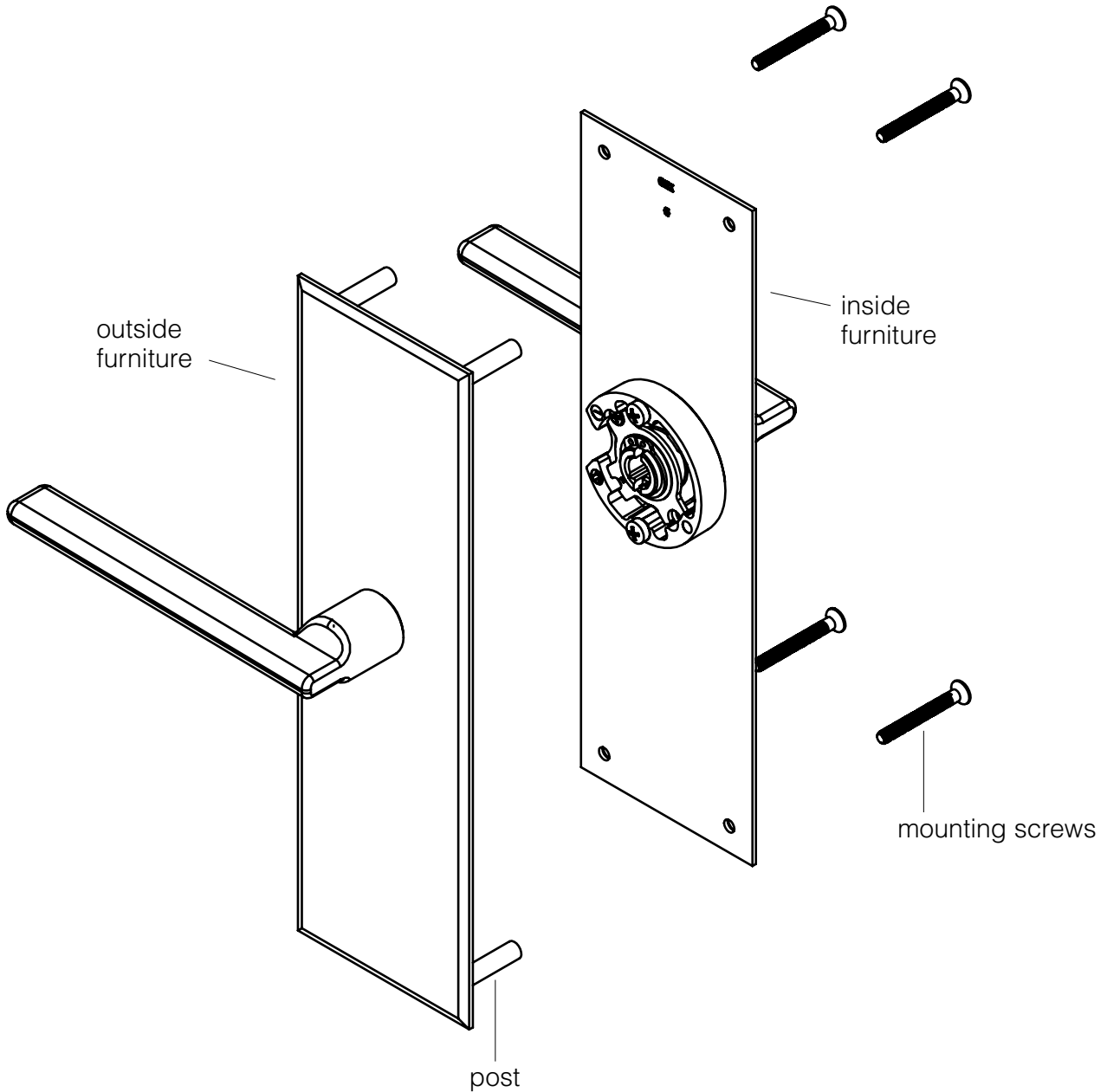

Gainsborough



TRILOCK™
BY GAINSBOROUGH

Designed in Australia by Gainsborough Hardware Industries Limited, Melbourne, Australia. A.B.N. 25 004 792 269

www.gainsboroughhardware.com.au