

Item: CMAB8B

Assembly Instructions

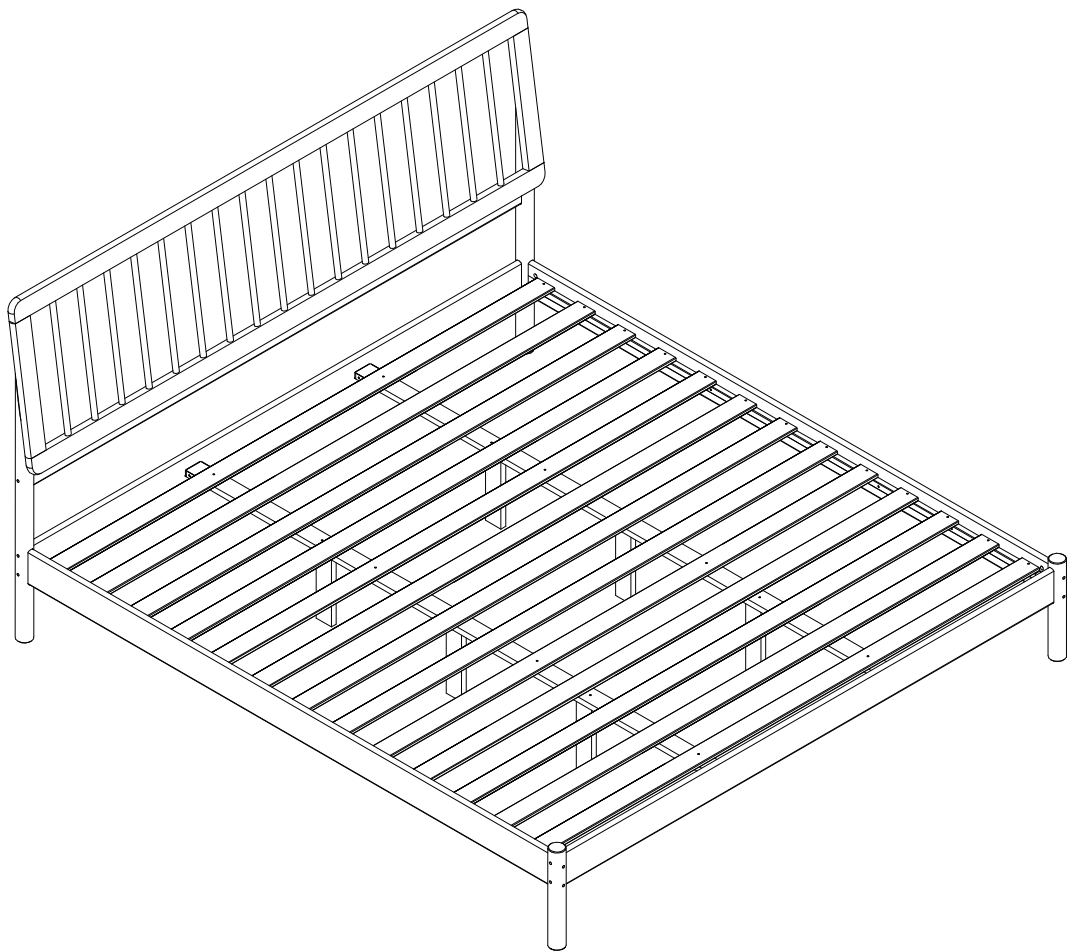

Please visit our website for the most current instructions, assembly tips, to report damage or request parts. www.walkeredison.com

Revised 08/23-V1

General Assembly Guidelines

- I. Ensure that all parts and hardware are available before beginning assembly.
- II. Follow each step carefully to ensure the proper assembly of this product.
- III. Two people are recommended for ease in the assembly of this product.
- IV. The three main types of hardware used to assemble this product are : wood dowels , screws and bolts.
- V. A Phillips head screwdriver and slotted head screwdriver is required for the assembly of this Product.

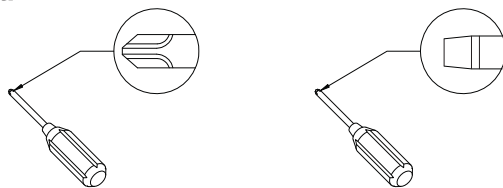

- VI. Power tools should not be used to assemble this product .

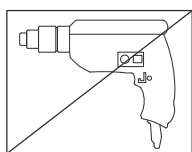



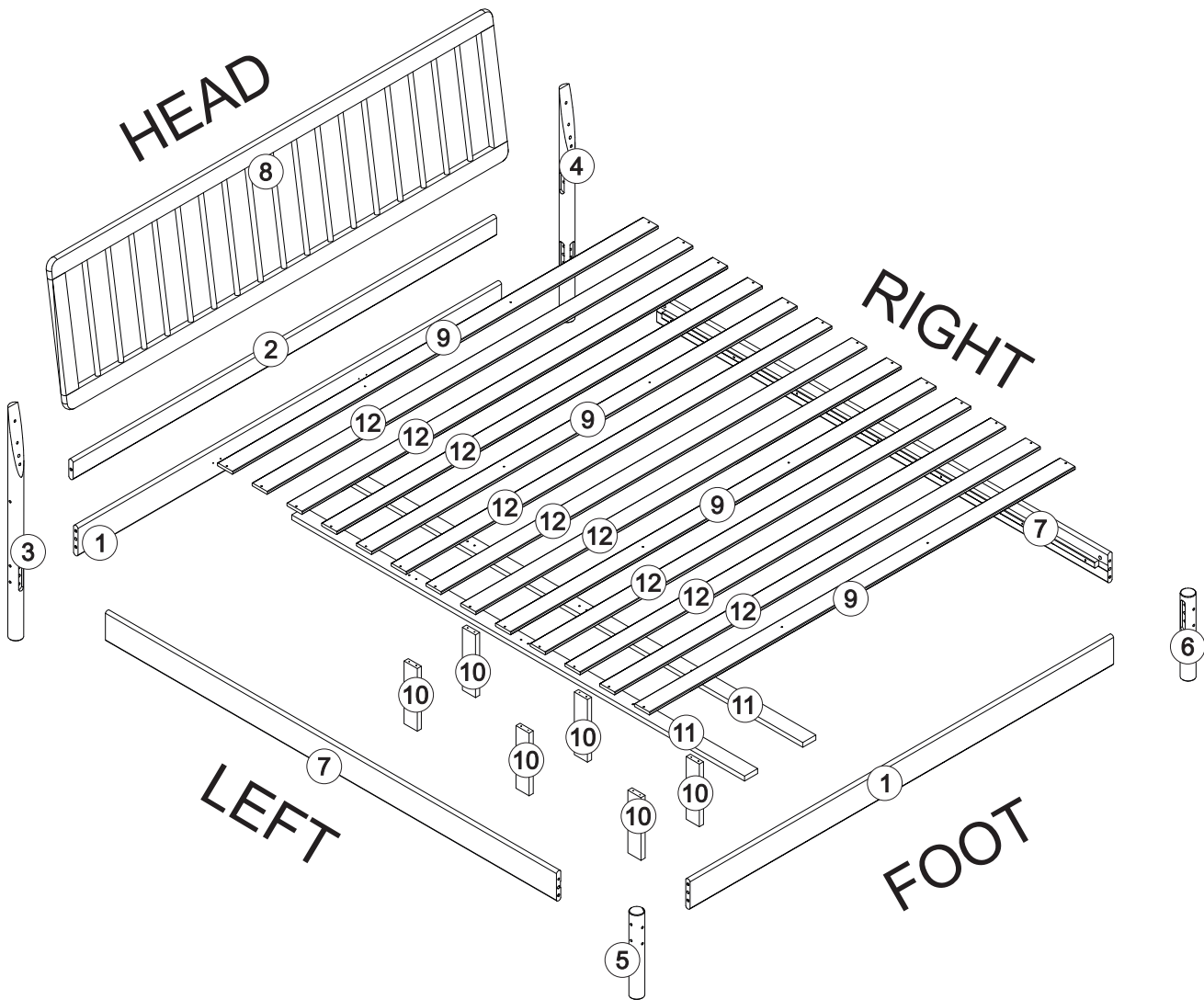



Parts List

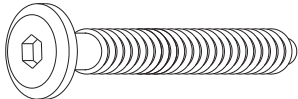
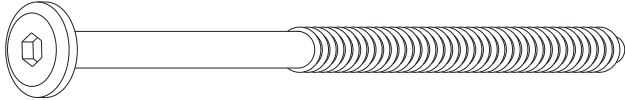
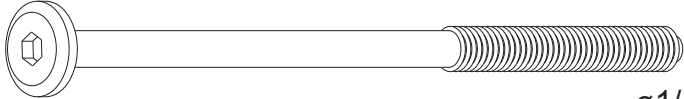

Part #	Description	Qty
1	Headboard and Footboard	02 pcs
2	Headboard Middle Slat	01 pcs
3	Headboard Left Post	01 pcs
4	Headboard Right Post	01 pcs
5	Left Post Of The Footboard	01 pcs
6	Right Post Of The Footboard	01 pcs
7	Bed Crosspiece	02 pcs
8	Headboard	01 pcs
9	Slat 4 Hole	04 pcs

Part #	Description	Qty
10	Center Foot	06 pcs
11	Center Slat	02 pcs
12	Slat 2 Hole	09 pcs

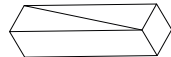
Hardware List

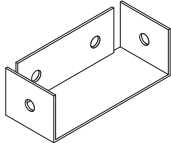
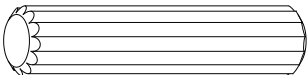
A		ø7,0"*40mm	Bolt	18 pcs
B		ø7,0"*80mm	Bolt	14 pcs
C		ø1/4"*90mm	Bolt	04 pcs
D			Hex key	01 pc
E			Nut	04 pcs
F		ø4.0*30mm	Screw	34 pcs
G		81mm	Space Block	02 pcs
I		ø4.0*16mm	Screw	16 pcs
J			Support	04 pcs
K		ø10*40mm	Dowel	10 pcs

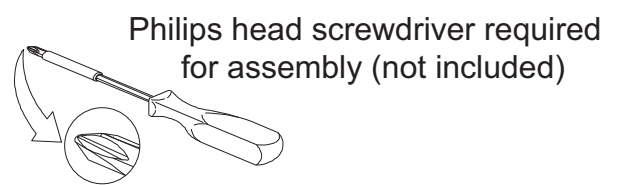
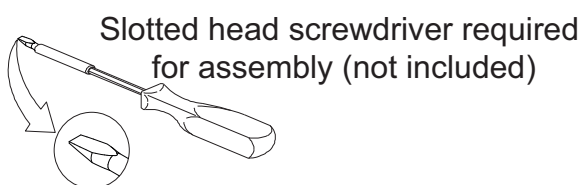

The hardware quantities listed above are required for proper assembly. Some extra hardware may also have been included.

Step 1

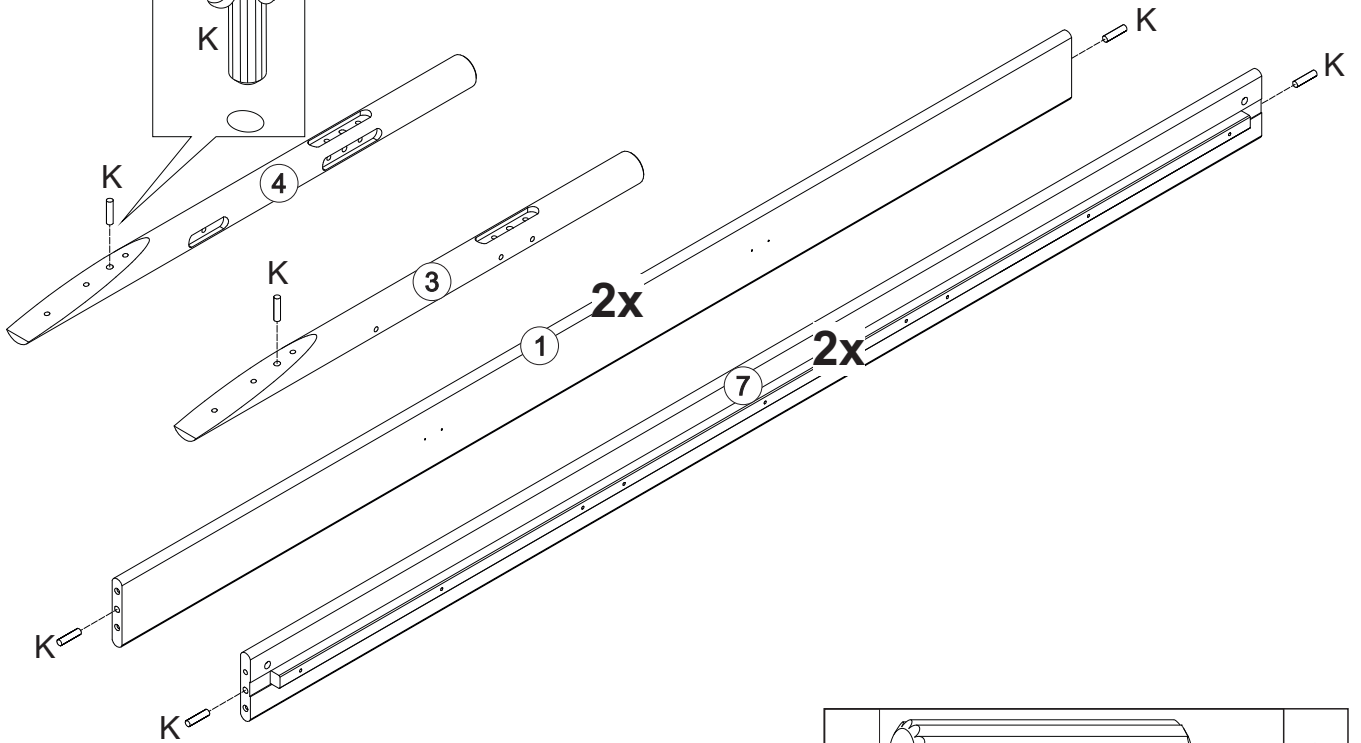
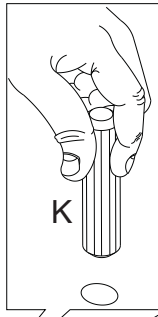

Insert the dowel K into parts 1, 3, 4 and 7

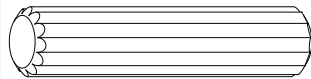
K		10
<small>ø10*40mm</small>		

Step 2



Please assemble on a clean soft surface to avoid damage.

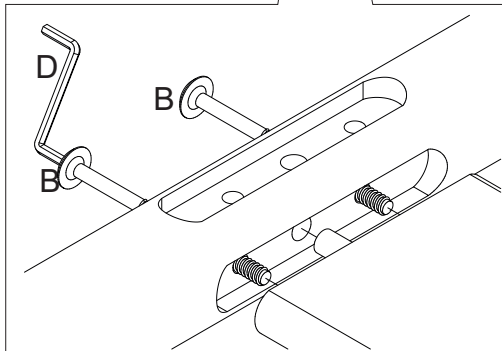
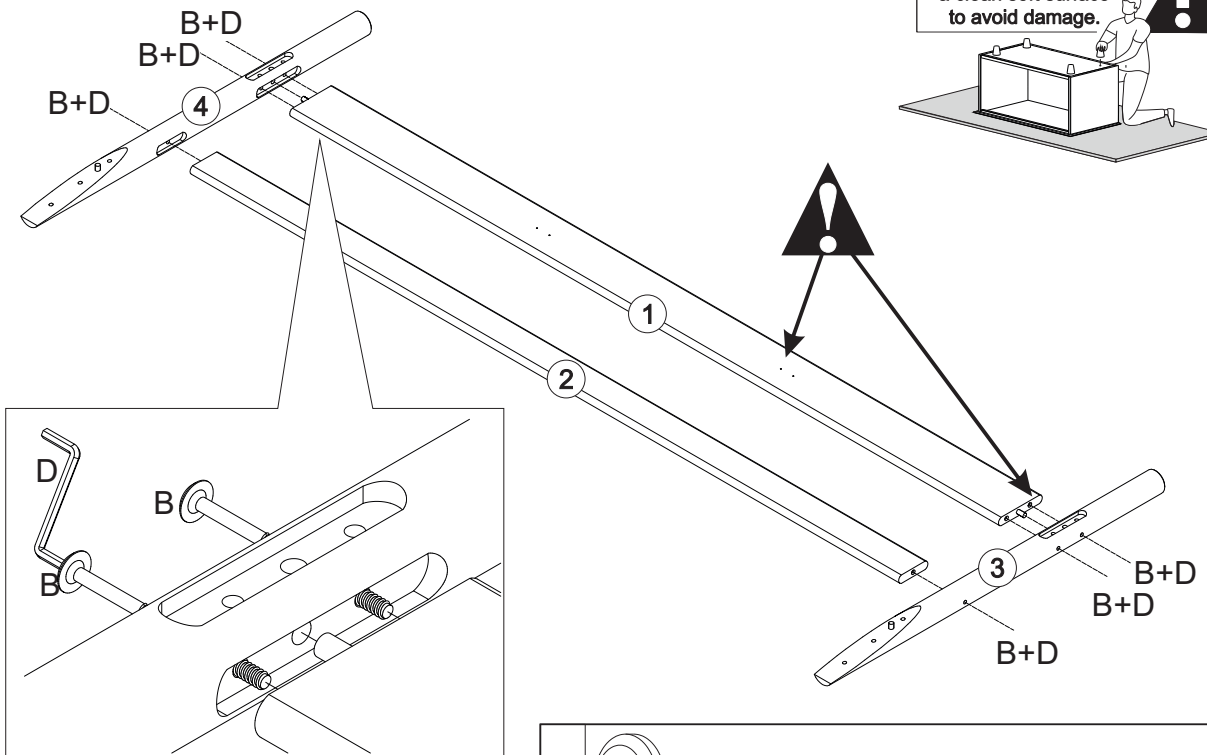

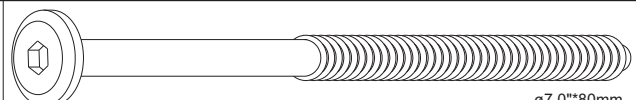
B		06
<small>ø7,0**80mm</small>		

D		01
---	---	----

Attach parts 1 and 2 to parts 3 and 4 with screw B, using hex key D

Step 3

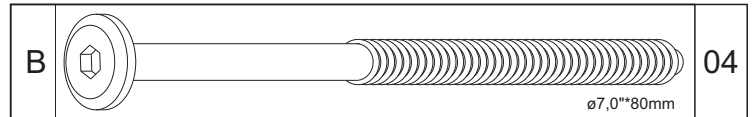
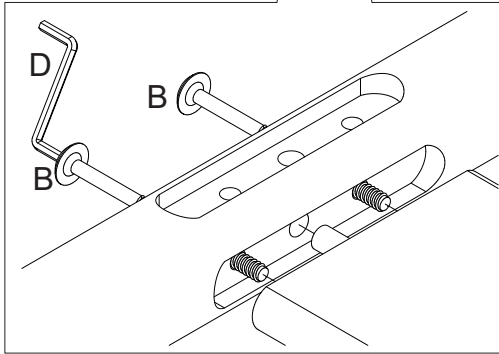
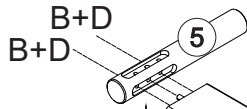

Attach parts 1 to parts 5 and 6 with screw B, using hex key D.

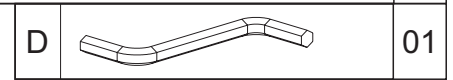

Step 4

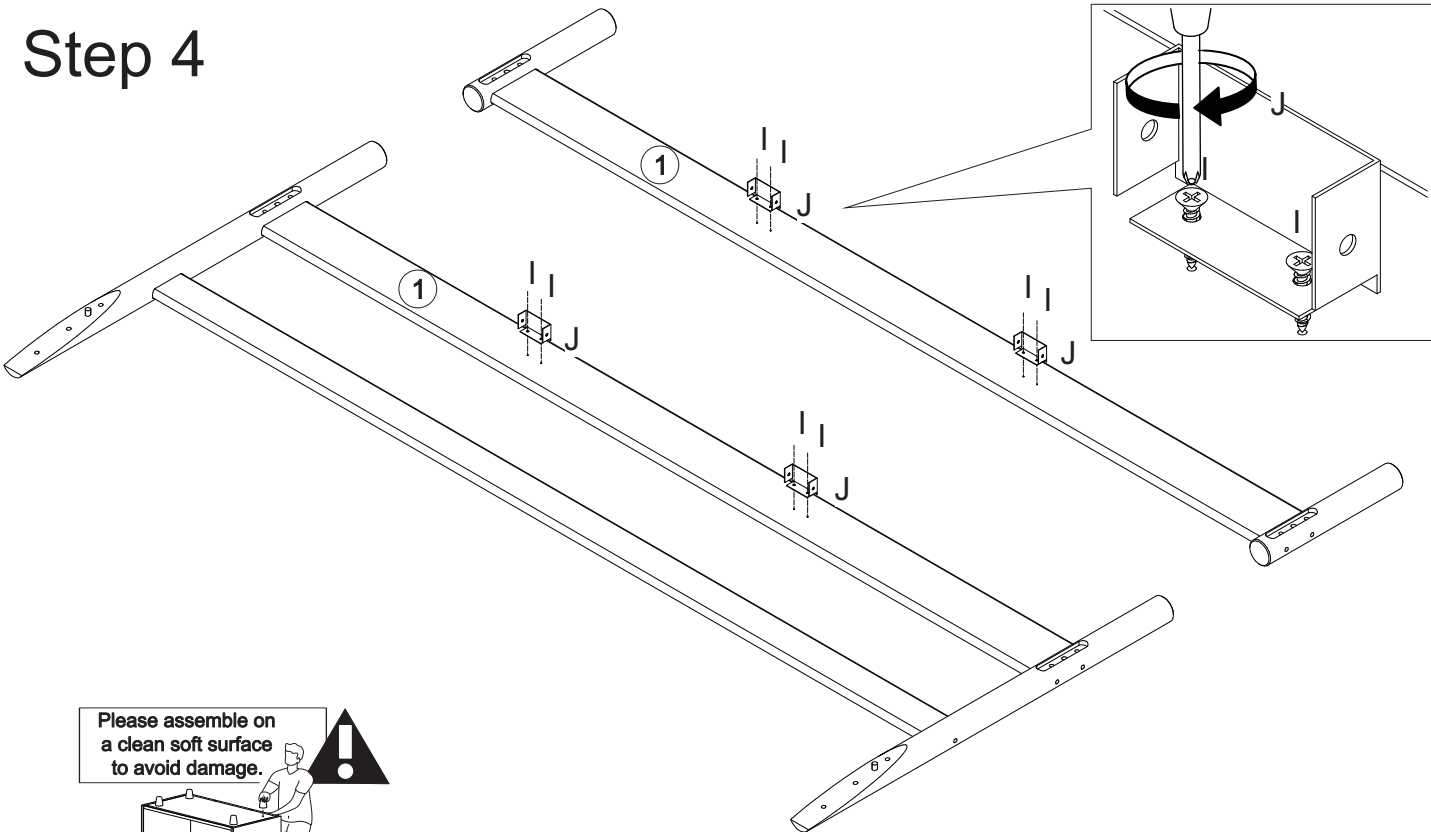



I		08
J		04

Apply support J on part 1 and fix with screw I, using the Phillips head screwdriver.

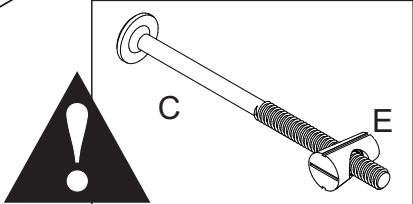
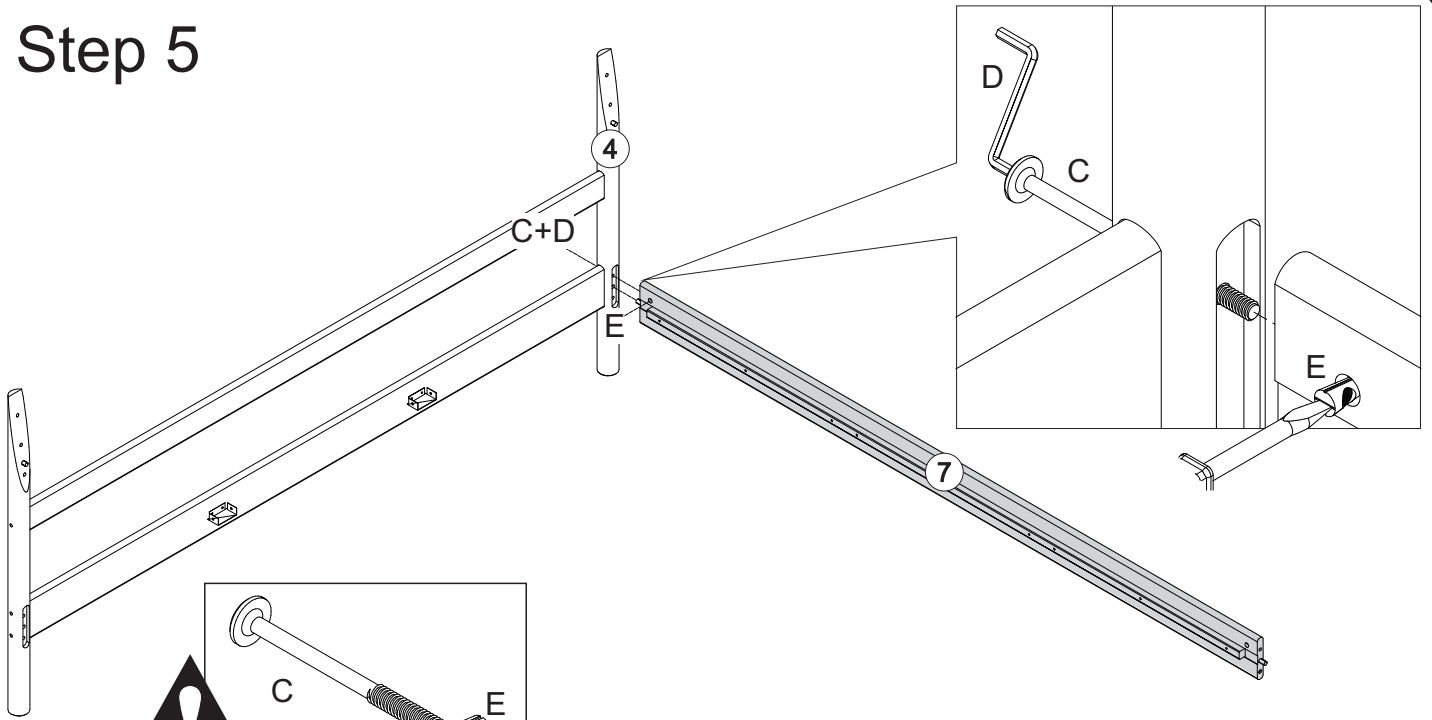
Step 5



C		01
<small>ø1/4**90mm</small>		

D		01
---	---	----

E		01
---	--	----

Attach part 7 with the post 4, fix with screw C and nut E using a Hex Key D. If necessary, use a flathead screwdriver.
 "If necessary, use a slotted head screwdriver»

Step 6

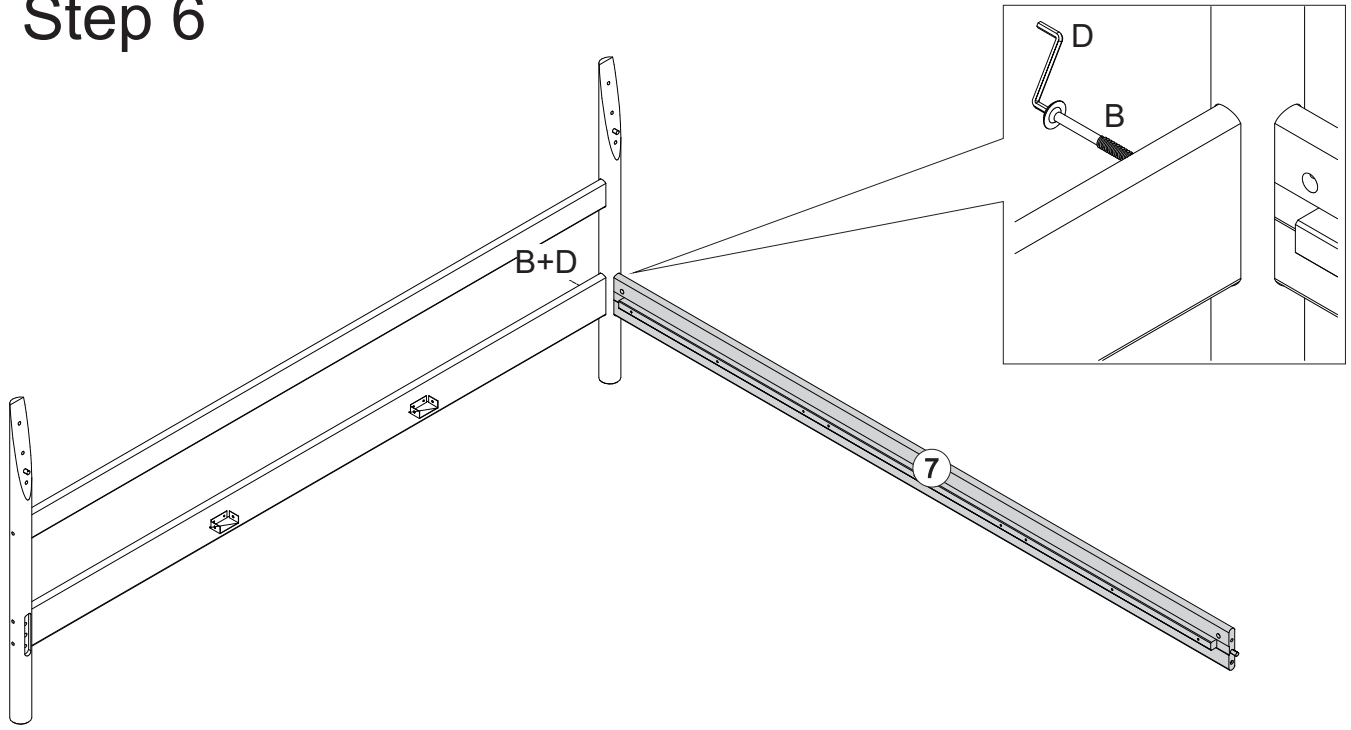

B		01
<small>ø7,0**80mm</small>		

D		01
---	---	----

Attach part 7 with the Headboard Right Post 4, fix with the screw B using the hex key D.

Step 7

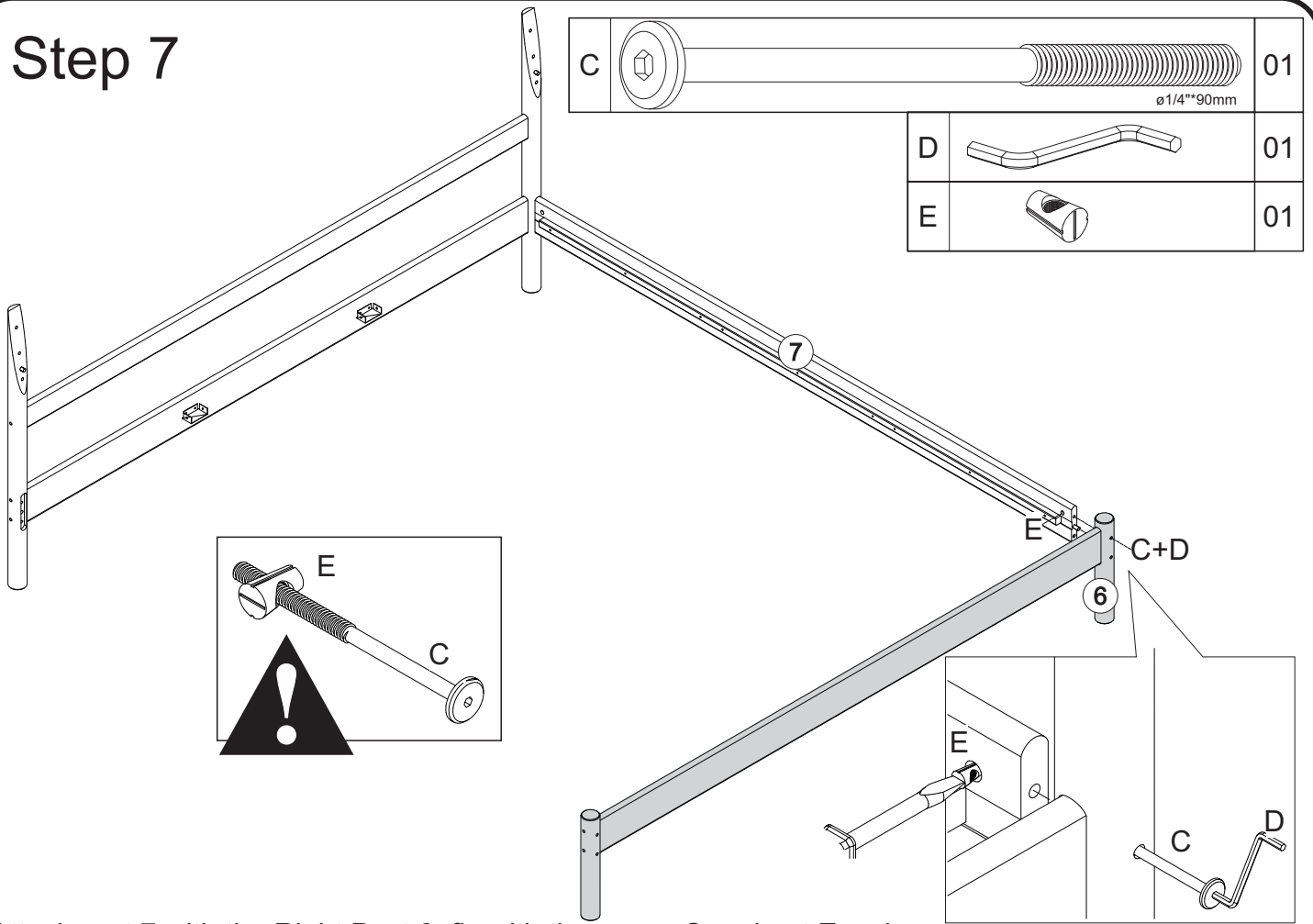

Attach part 7 with the Right Post 6, fix with the screw C and nut E, using the hex key D. If necessary, use a slotted head screwdriver.

Step 8

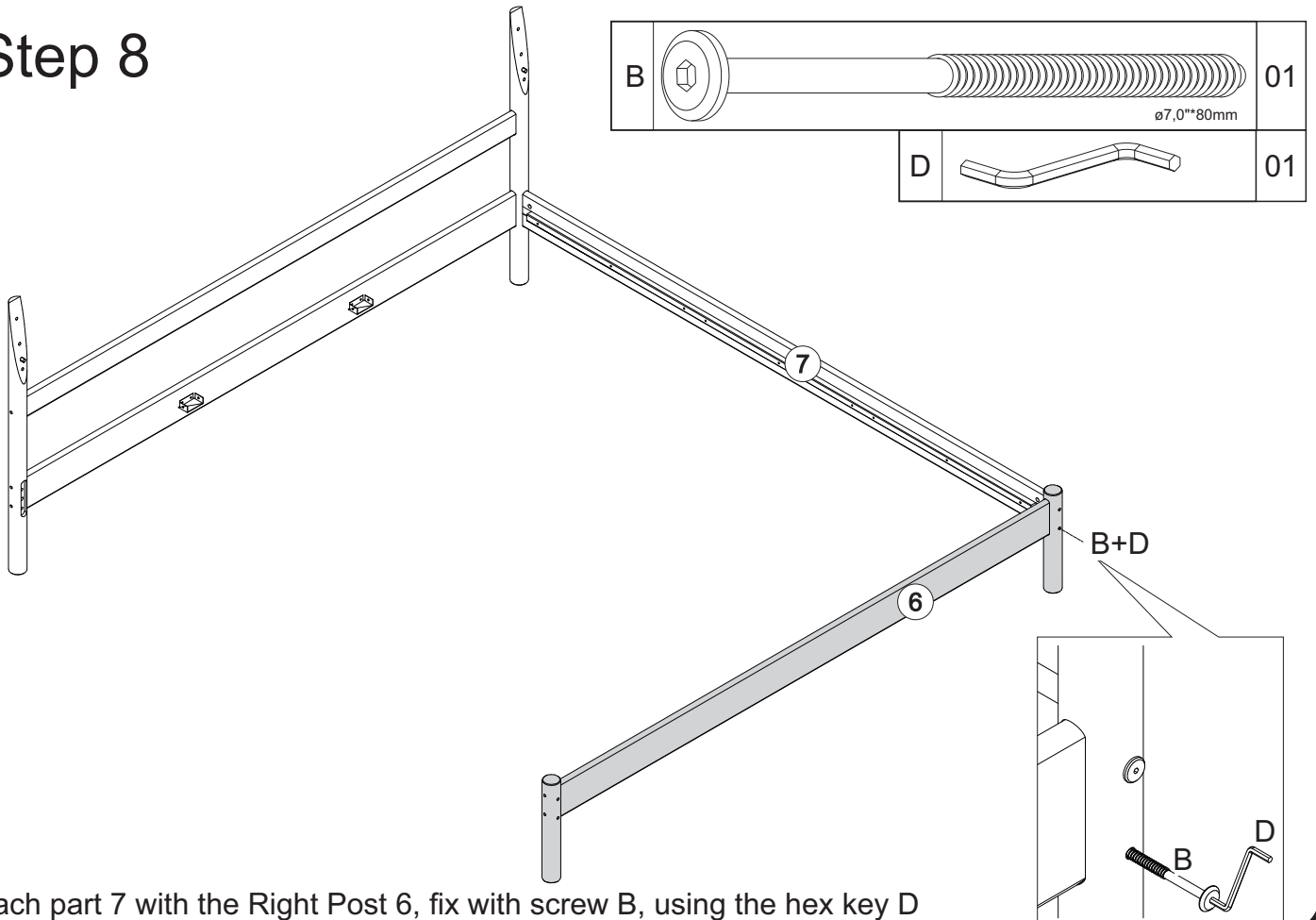

Attach part 7 with the Right Post 6, fix with screw B, using the hex key D

Step 9

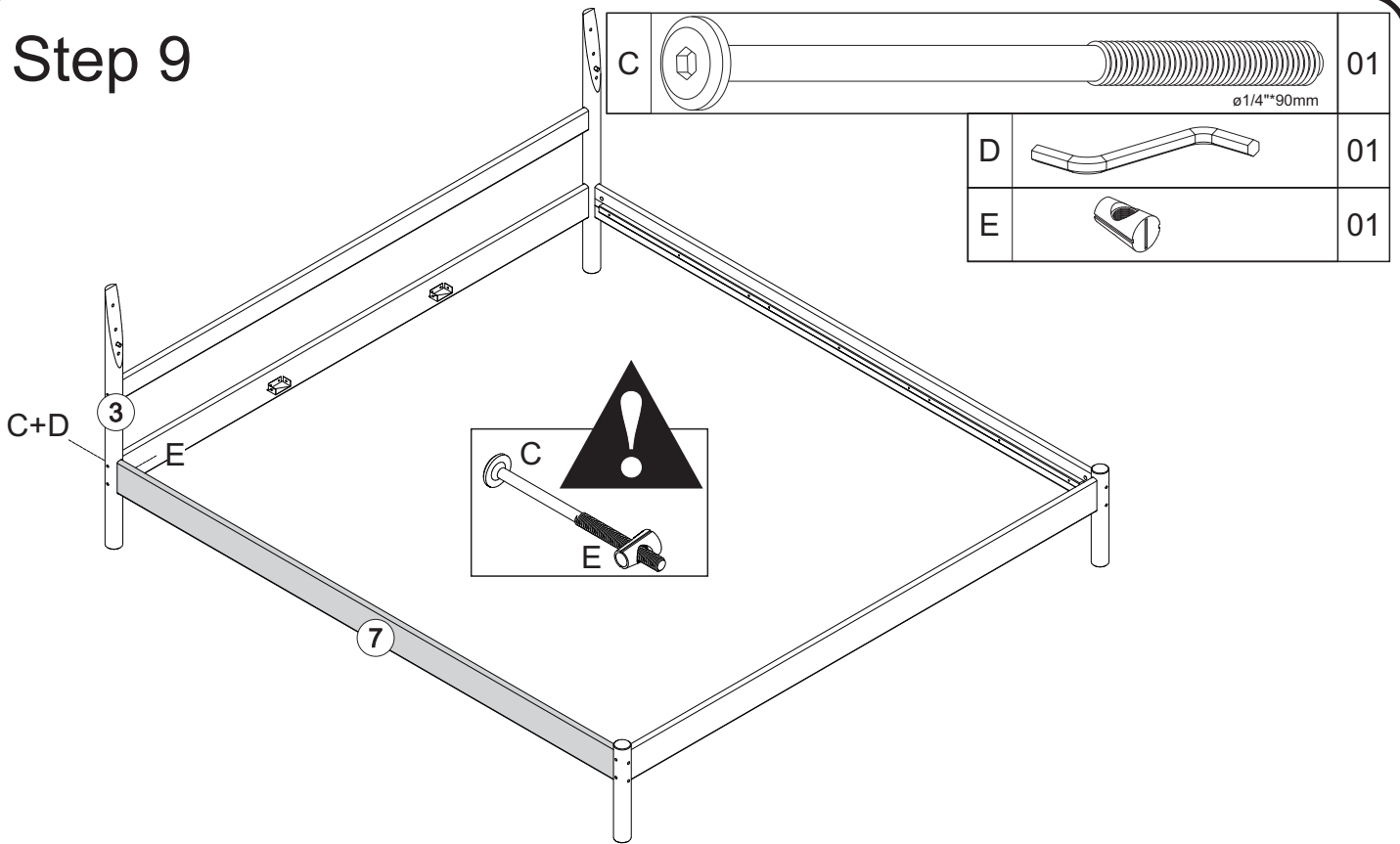

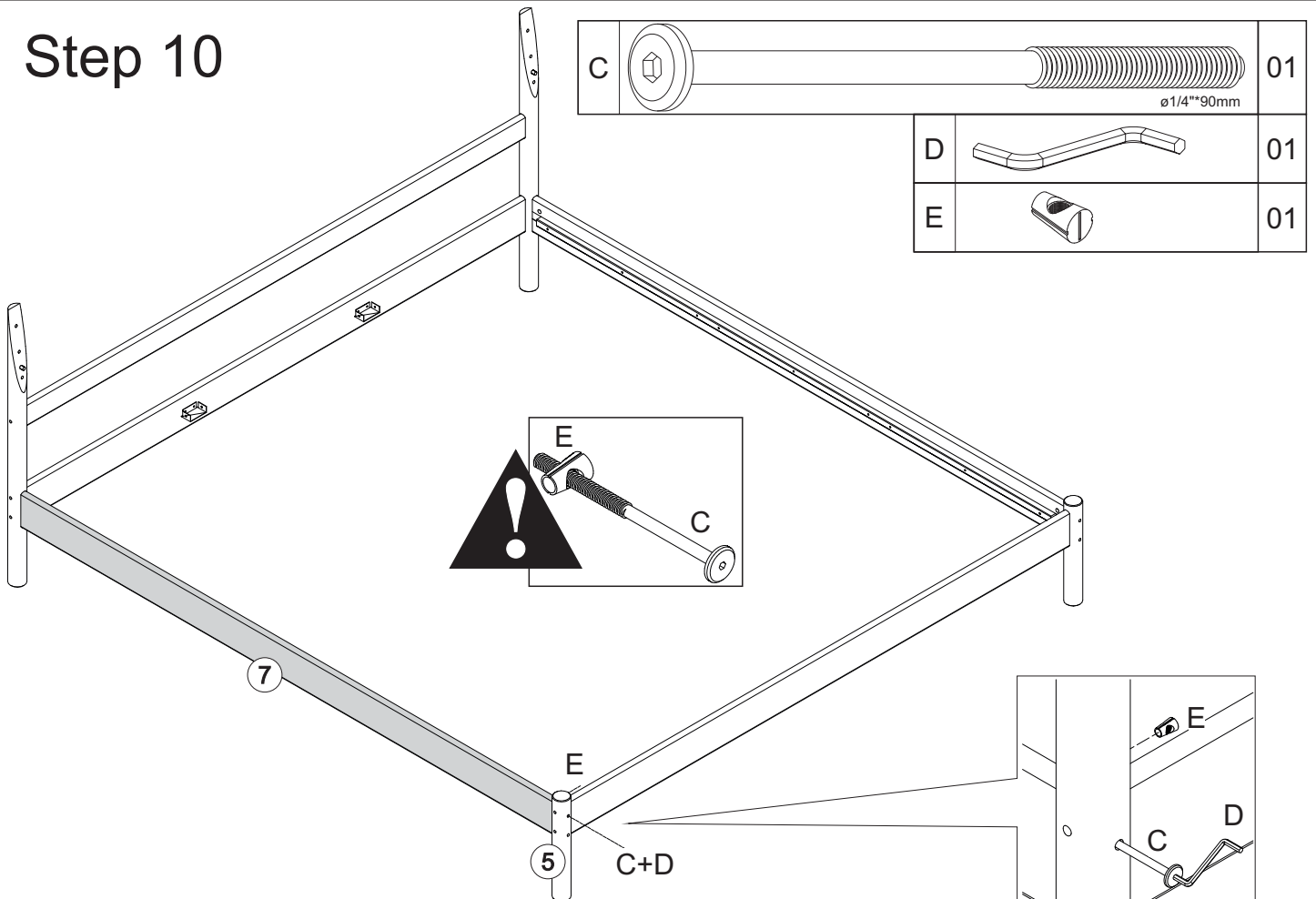

Attach part 7 with the Headboard Left Post 3, fix with screw C and nut E, using the hex key D. "If necessary, use a slotted head screwdriver»

Step 10

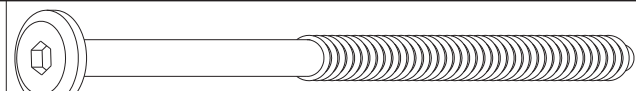

Attach part 7 with the Left Post 5, fix with screw C and nut E, using the hex key D. "If necessary, use a slotted head screwdriver»

Step 11

B	 <small>ø7,0**80mm</small>	02
D		01

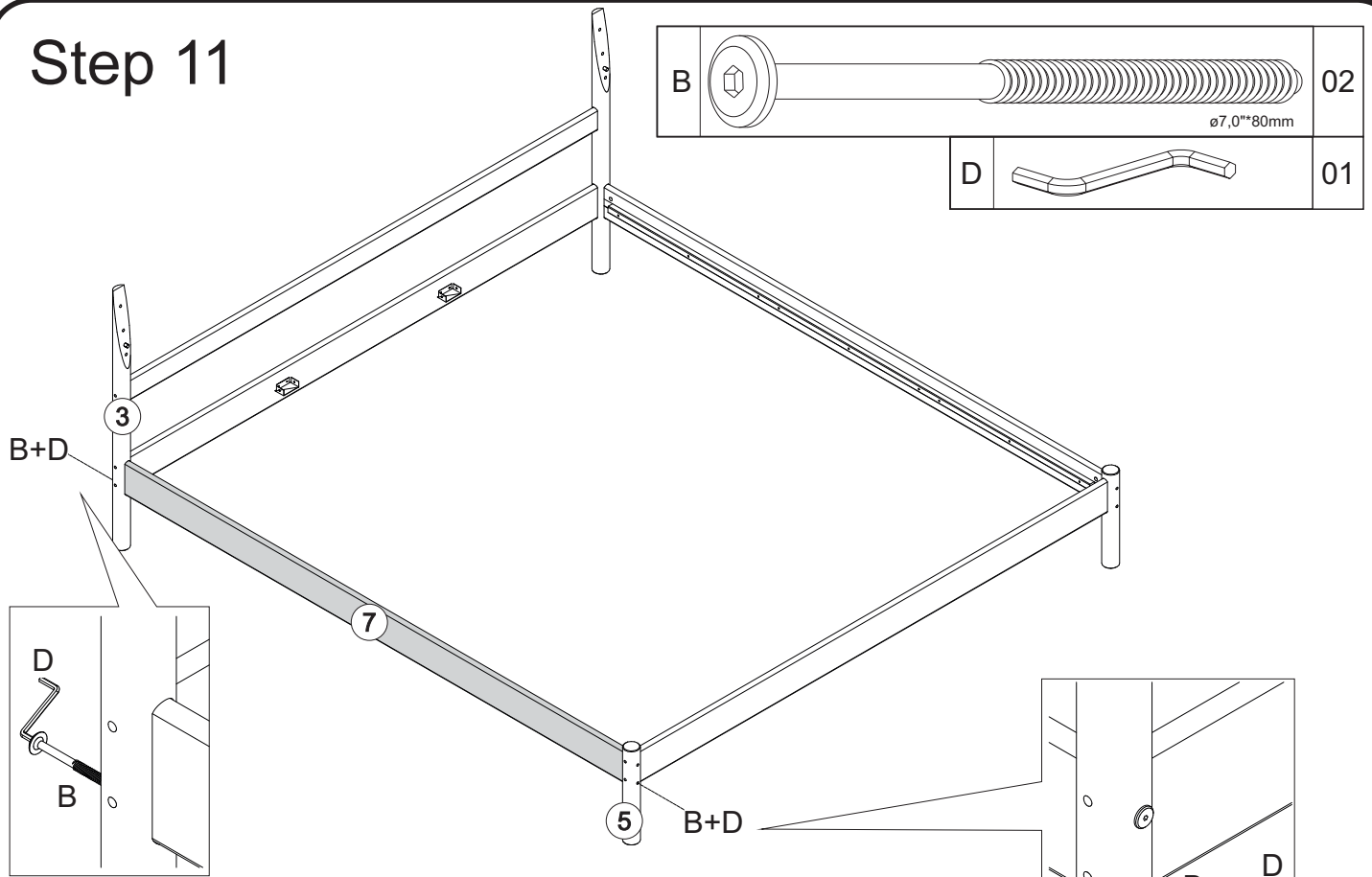

Attach part 7 with the Headboard Left Post 3 and the Left Post 5, fix with screw B, using the hex key D

Step 12

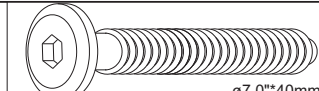
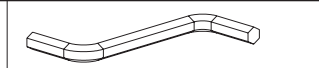
A	 <small>ø7,0**40mm</small>	06
D		01

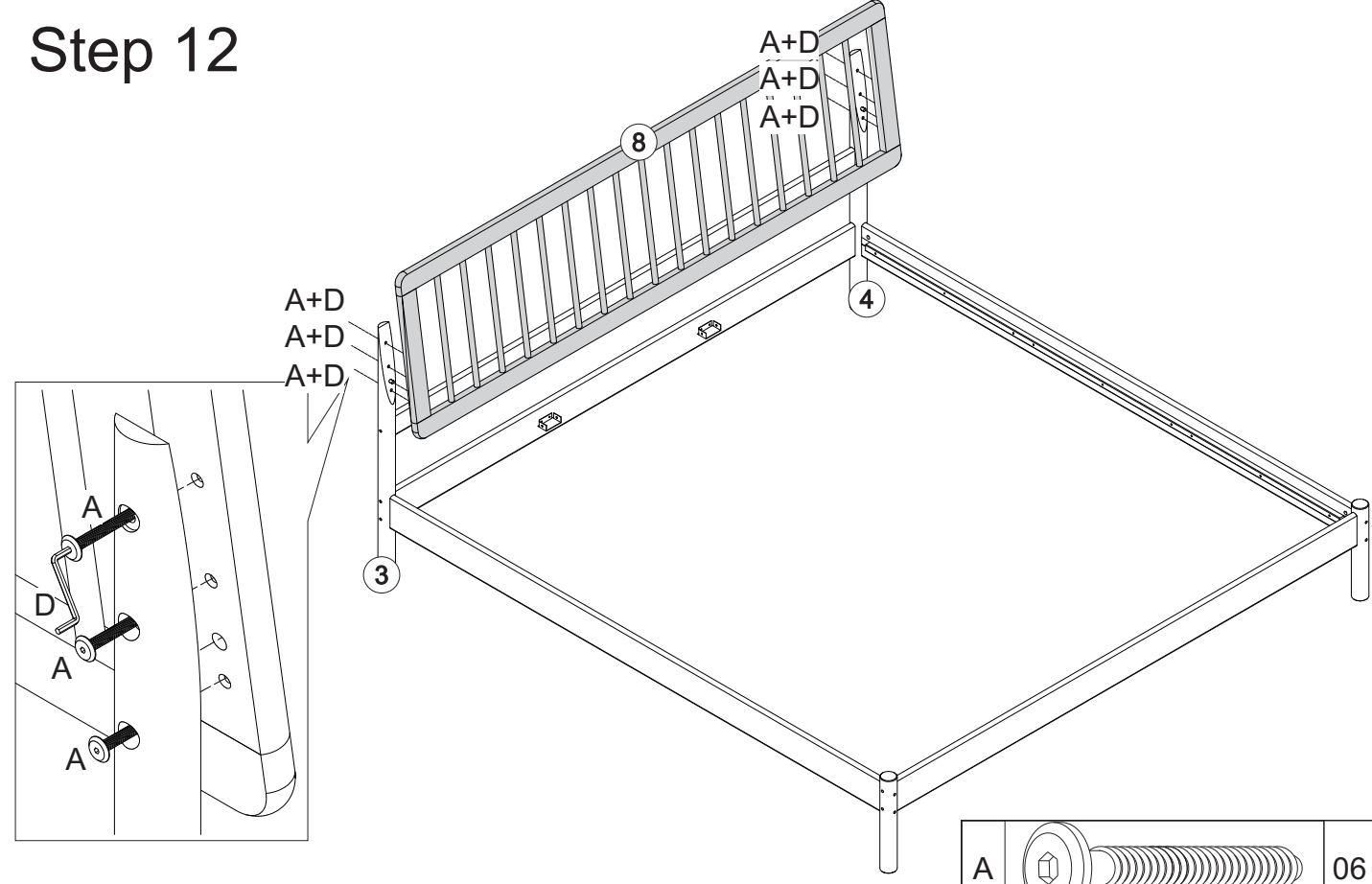

Attach part 8 on the Headboard Left Post 3 and the Headboard Right Post 4, fix with screw A, using the hex key D

Step 13

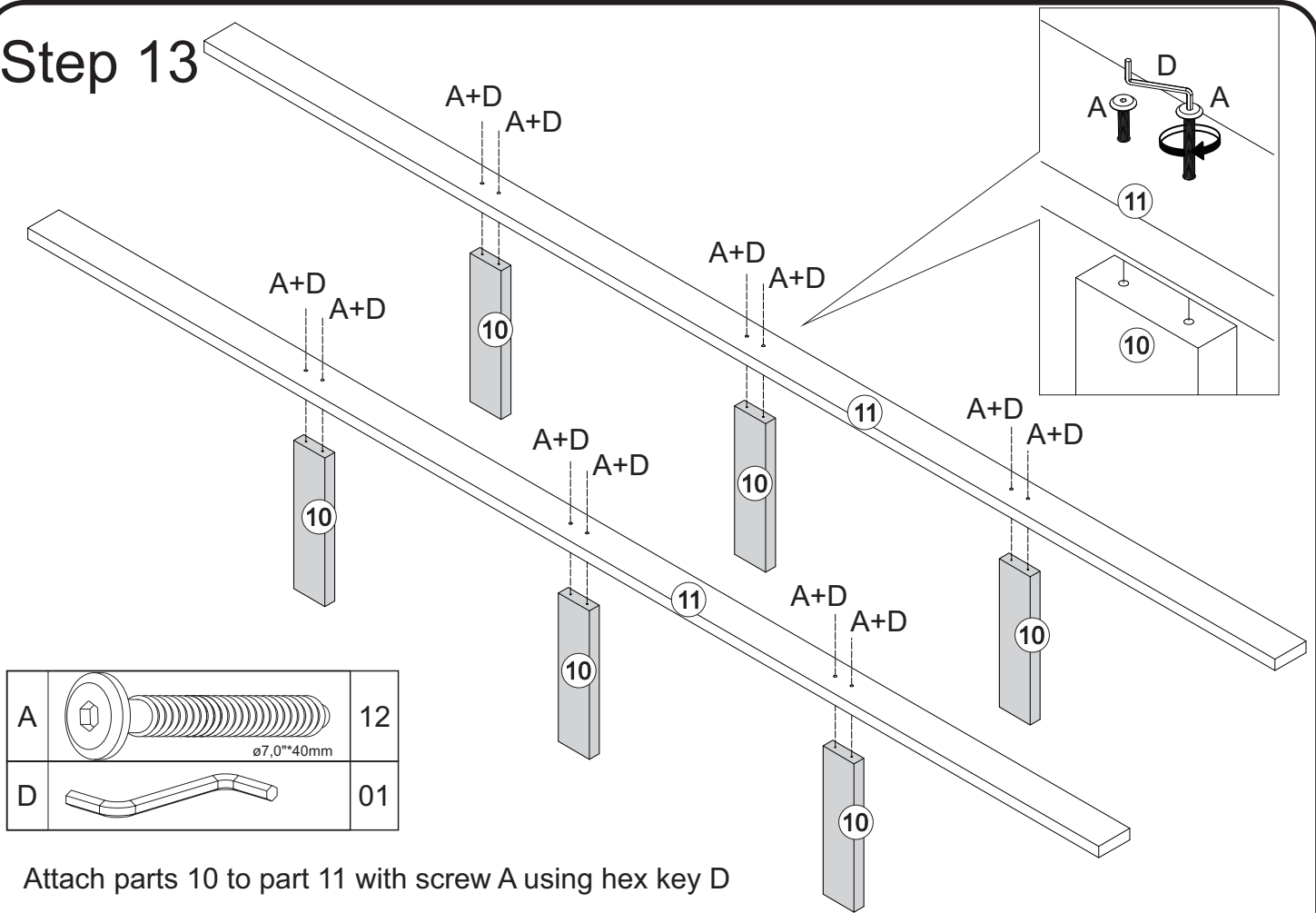

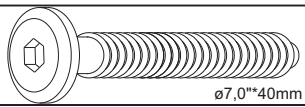
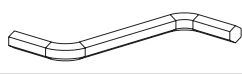
A	 ø7.0*40mm	12
D		01

Attach parts 10 to part 11 with screw A using hex key D

Step 14

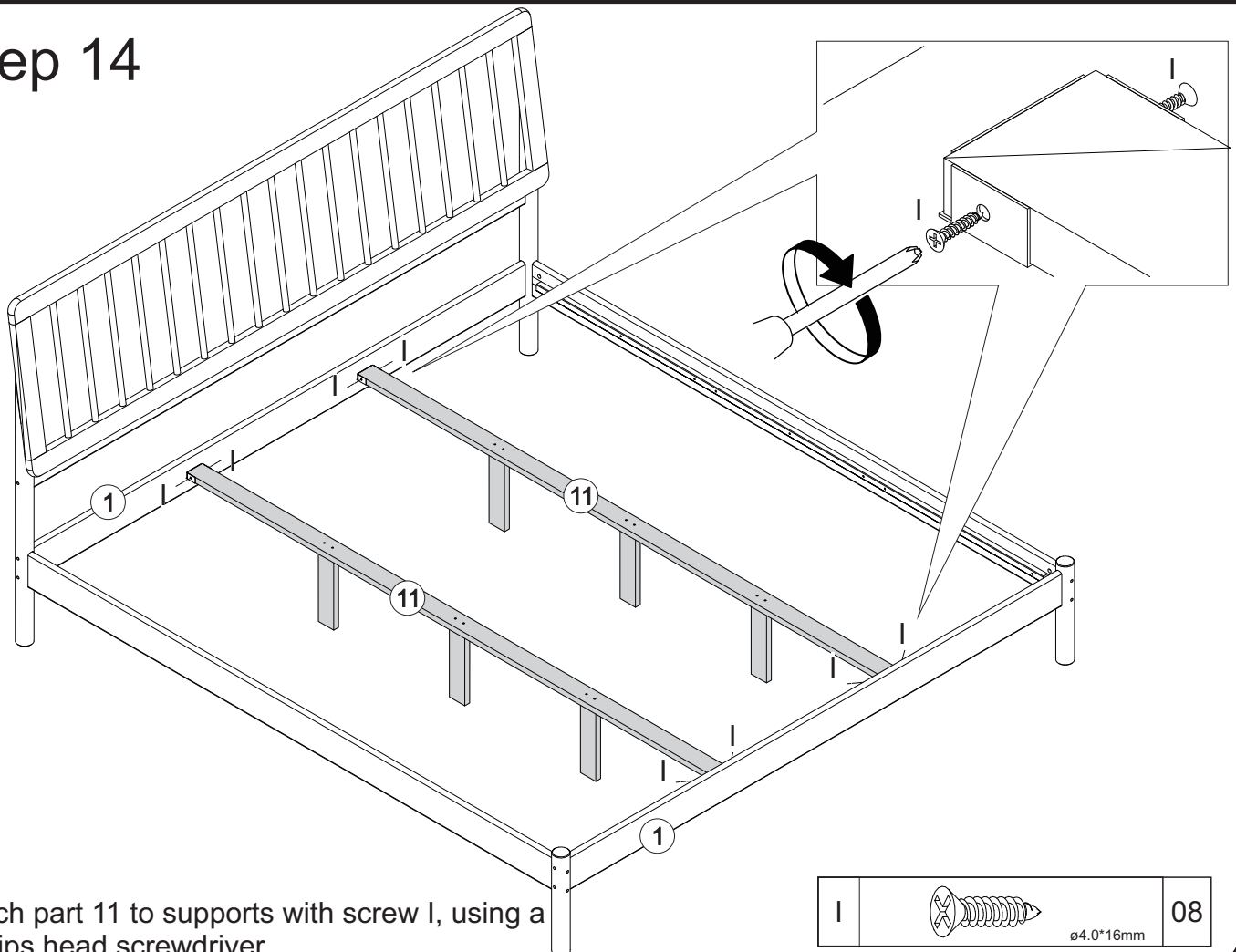

Attach part 11 to supports with screw I, using a Phillips head screwdriver.

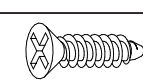
I	 ø4.0*16mm	08
---	--	----

Step 15

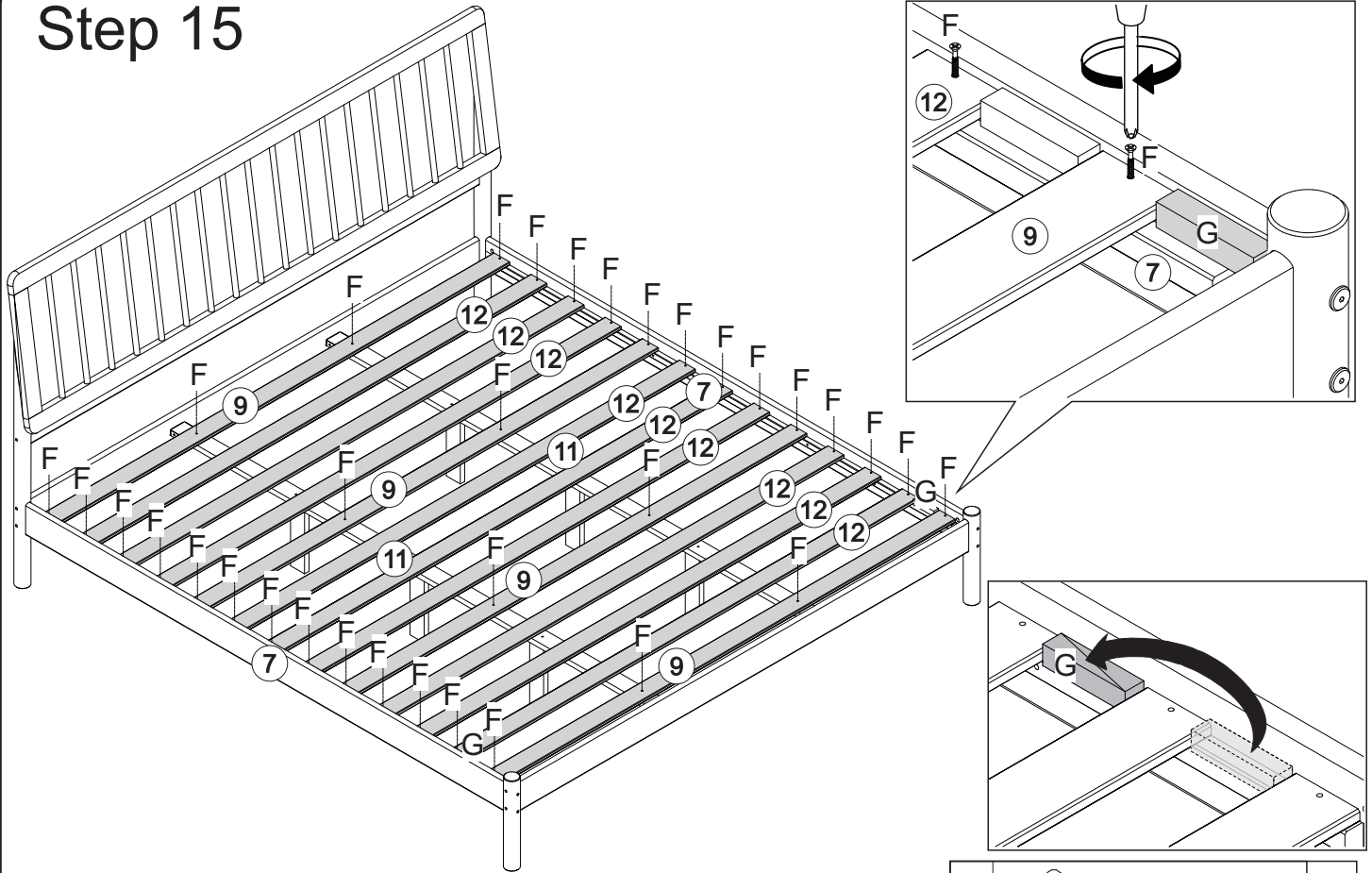

Align part 7 with 9, and use hardware G to space the next parts 9 and 12.
Join pieces 7, 9, 11, and 12 with screw F using a Phillips head screwdriver.

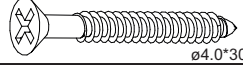
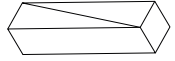
F	 $\phi 4.0 \times 30\text{mm}$	34
G	 81mm	02

Step 16

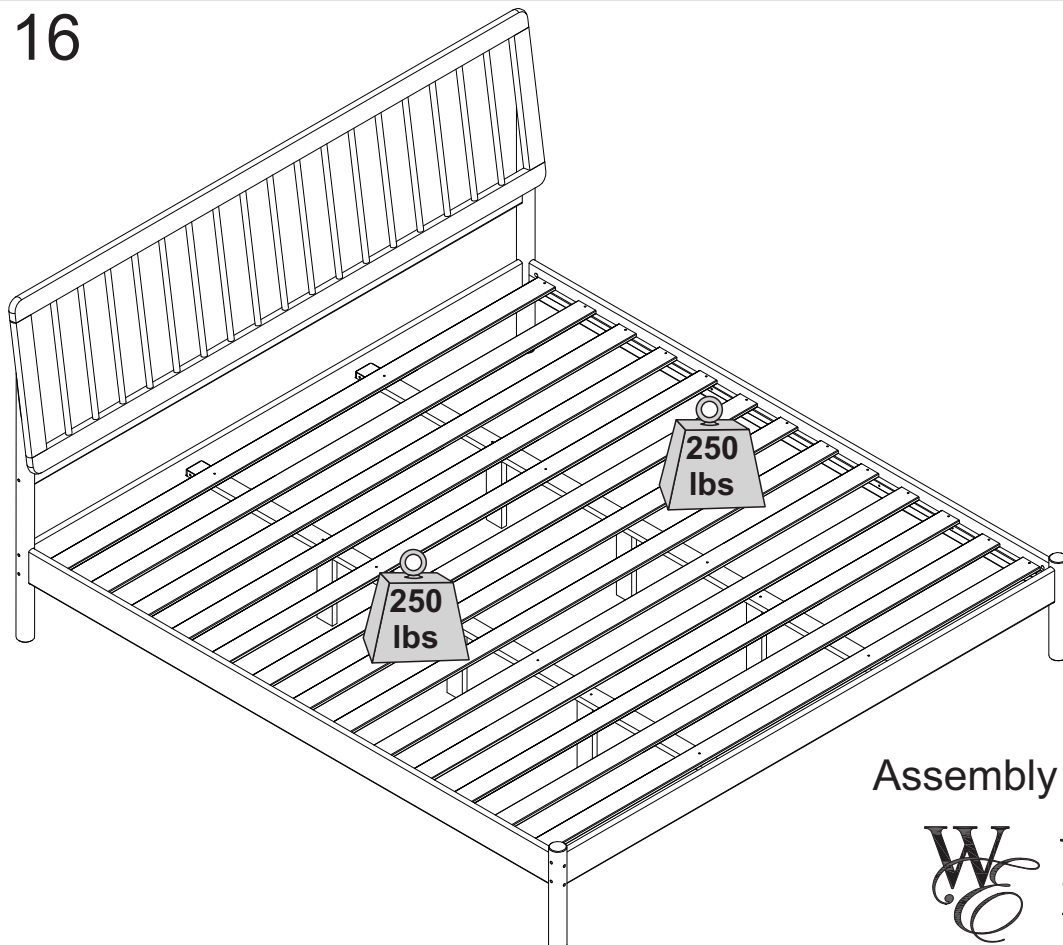

Assembly Complete!

 Walker Edison®