

Adventure Starts Here.

44" X27" RECTANGLE COFFEE TABLE

**SEAHAWK
DESIGNS**

EST. 2005

! NOTICE

- Do not overtighten hardware.
- Do not exceed the weight capacity of this item.
- Only use this item for what it is intended for, improper use will void any warranty.
- Firmly secure all bolts, screws and nuts before use.
- Reconfirm that all bolts, screws, and nuts are firmly secured every 90 days.
- Keep this furniture clear of all uncontrolled open flames or flammable/combustible materials. Exposure to fire, high heat, or embers will permanently damage the material.
- To avoid stripping and cracking of the material, DO NOT use power tools for assembly.
- Always prioritize caution and safety throughout the assembly process.

TOOLS REQUIRED

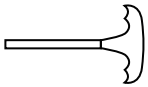

ALLEN WRENCH
(PROVIDED)

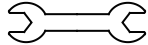

WRENCH
(PROVIDED)



330 LBS
WEIGHT
CAPACITY



SUGGESTED
2 PERSON
ASSEMBLY



ESTIMATED
ASSEMBLY
TIME: 20 MIN

HARDWARE

REF#: OP8048

1

SCREW
M6 x 70mm



4 PCS

2

BOLT
M6 x 65mm

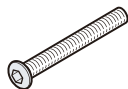

8 PCS

3

M6-NUT



8 PCS

4

M6-WASHER



8 PCS

5

SCREW HOLE PLUG



12 PCS

PARTS

REF#: OP8048

A

TABLE TOP

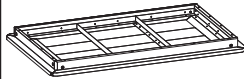

1 PC

B

SHELF

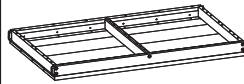

1 PC

C

LEG

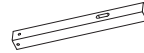

4 PCS

PRODUCT ASSEMBLY - OVERALL VIEW

Please refer back to this image during the assembly process for part placement.

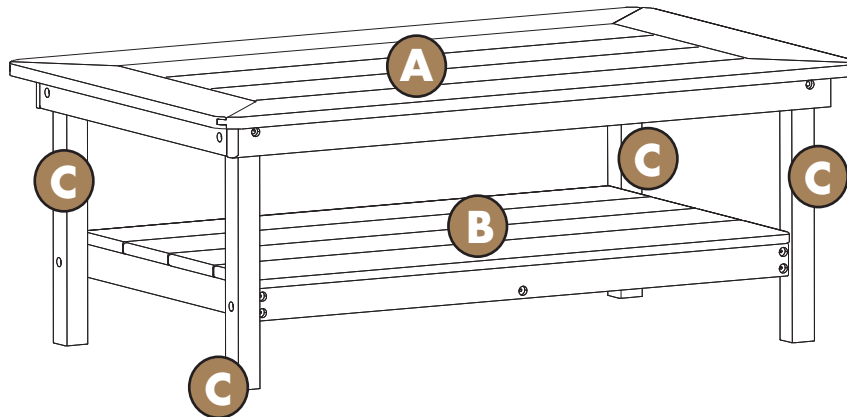

1

Step 1: Attach two Legs to the Shelf

- Place **Part B (Shelf)** on a flat, stable surface.
- Attach **2 - Part C** to **Part B (Shelf)** using **2 - M6 Screw (#1)** (see image below).
- Do not fully tighten the bolts yet. Tighten them to approximately 70% to allow for adjustments during final assembly.

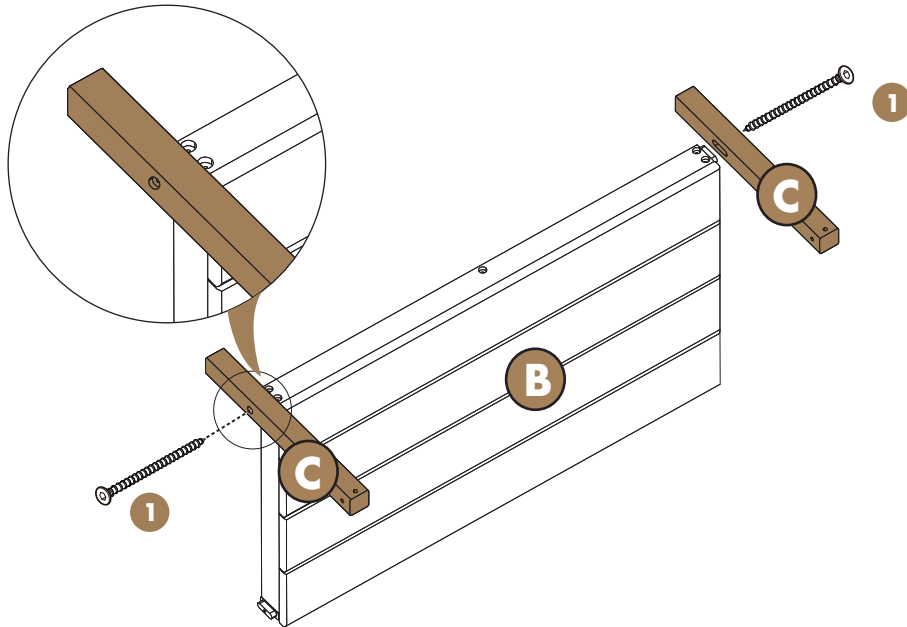

2

Step 2: Attach the other Legs to the Shelf

- Mirror the previous step (Step 1) on the opposite side. Secure the **2 - Part C (Leg)** to **Part B (Shelf)** using **2 - M6 Screw (#1)** (see image below).

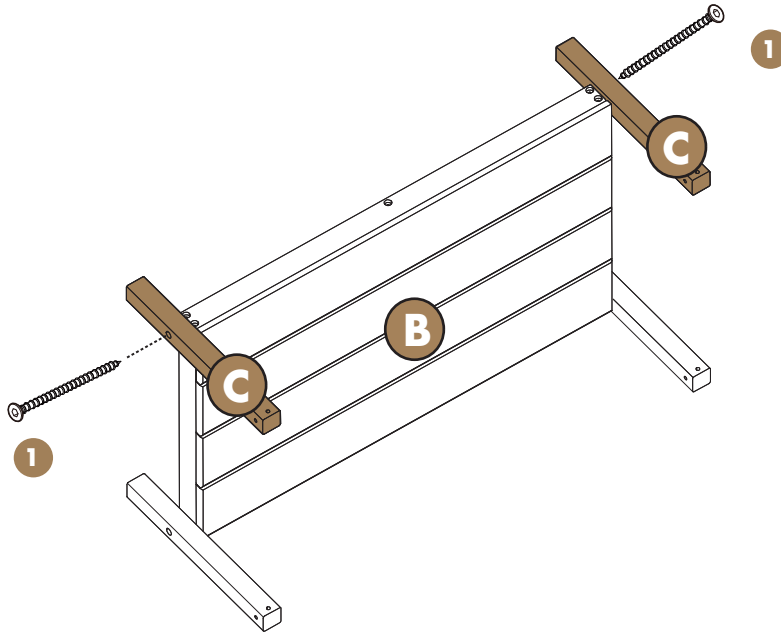

3

Step 3: Attach the Assembled Frame to the Table Top

- Place **Part A (Table Top)** upside down on a flat, stable surface.
- Attach the assembled frame (**Part C, Part B**) to **Part A (Table Top)** using **8 - sets of M6 Bolt (#2), M6 Washer (#4), and M6 Nut (#3)** (see image below).

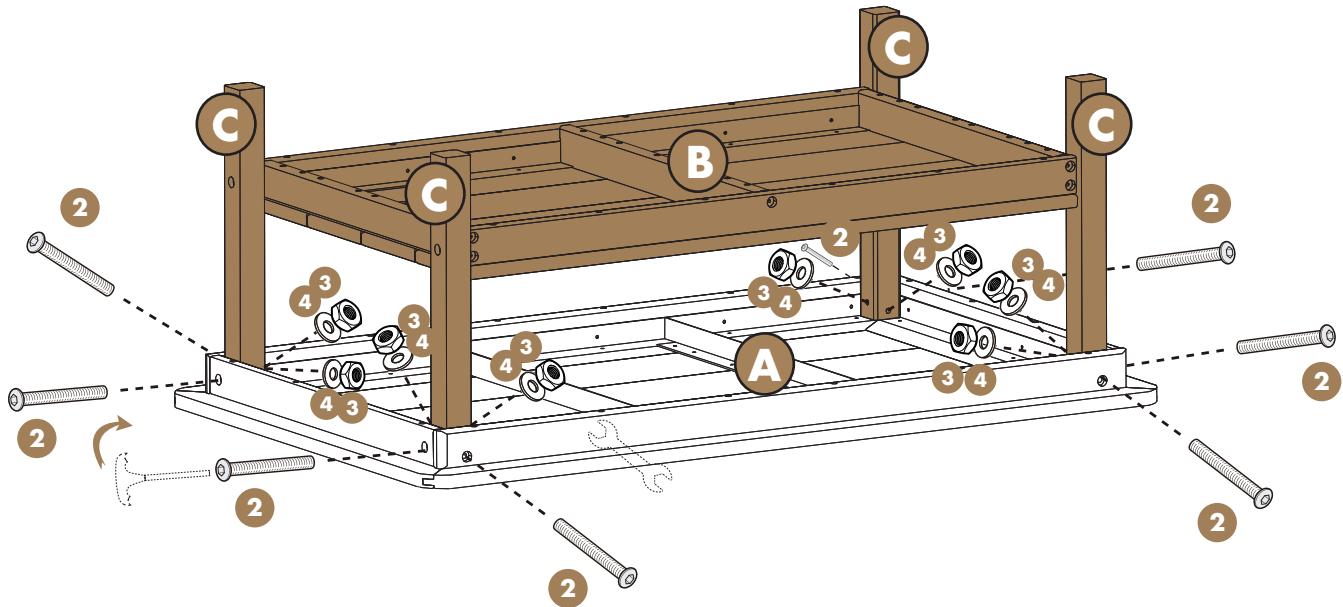

4

Step 4: Final Tightening and Stability Check

- Tighten all previously installed screws, bolts, and nuts. Check every connection to ensure the table is steady and stable.

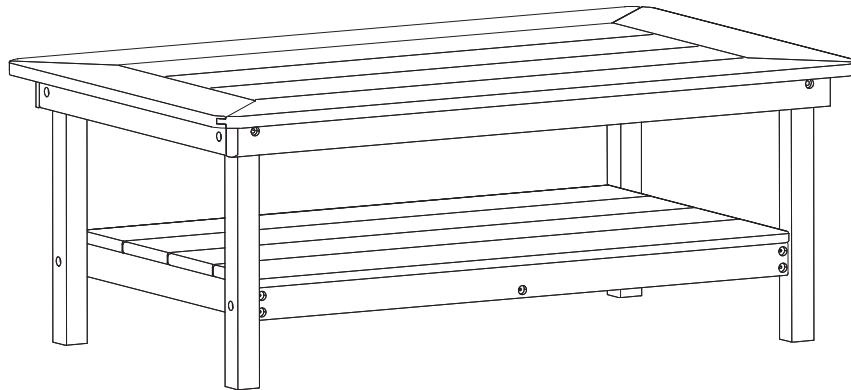

5

Step 10: Apply the Screw Hole Plugs

- Cover all exposed screw holes using **12 - Screw Hole Plug (#5)**. Insert all plugs into the exposed screw holes. Gently tap each plug into place using a rubber mallet to prevent damage. Ensure each plug is fully seated and flush with the chair surface (see image below).

ATTENTION: Do not use a metal hammer as it will damage the poly lumber.

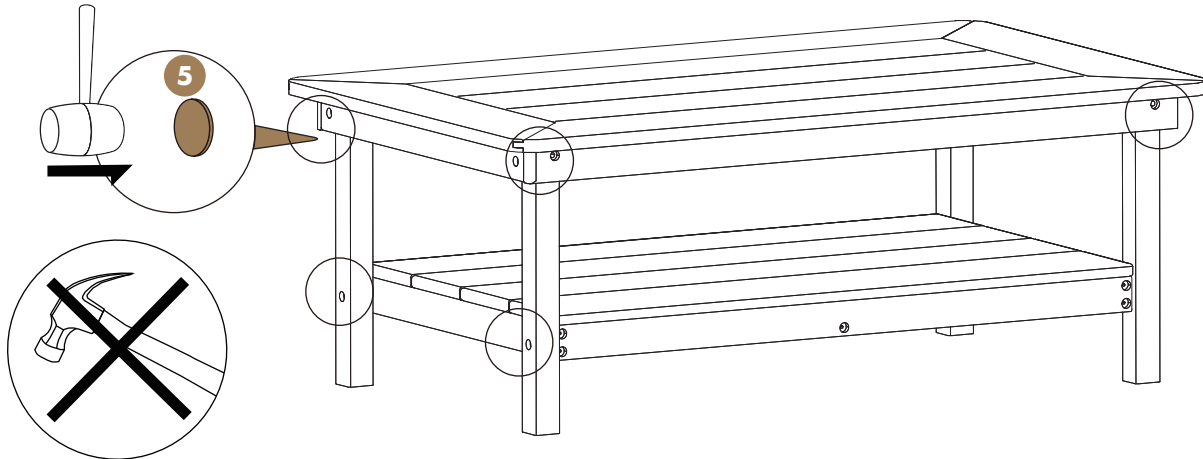

- **REGULAR CLEAN:** Mix **warm water and mild soap**. Use a **soft bristle brush** to gently scrub the surface and remove any dirt or stains.
- **QUICK CLEAN:** Simply wipe the furniture down using a damp cloth.

Tip: Cleaning your furniture regularly helps maintain its aesthetic appeal and extends its lifespan.

Enjoy!

Join our community and be the first to see what's new!

Follow us on socials:      



Quickly register your outdoor furniture purchase to activate your warranty and enjoy peace of mind with guaranteed product protection:



Have questions or need assistance? Reach out to our dedicated team at **(909) 284-1052** or email us at **cs@seahawkdesigns.com**.