

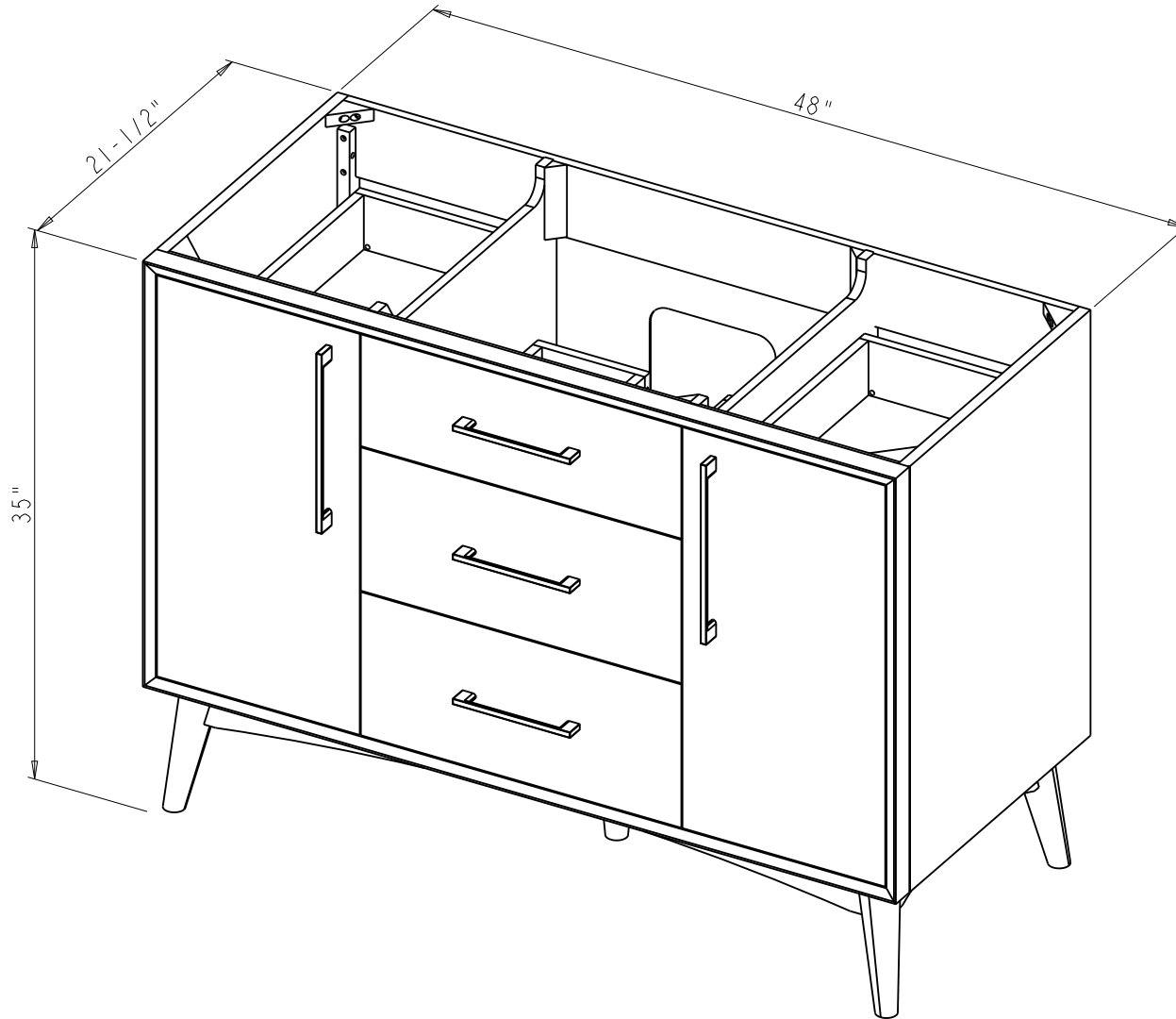

Specification:

1. Finish: See Table
2. Hardware: See Table
3. Hinge: Door:700.0537.25 + 600.1234.05 ( 4 pcs )  
Tipout:700.0536.25 + 600.1234.05 ( 2 pcs )
4. Slide: USE58-300-18 + USCLIP2ND-4W ( 8 set )
5. Lid Stay ( 1 PC )
6. leg levelers ( 4 pcs )
7. The tolerance is +/- 1/8"



Item number	Finish	Deco Hardware			
		Item number	Qty	Item number	Qty
VN2DAS-48-DW-NT	Dark Walnut	635-256BG	2	635-160BG	3
VN2DAS-48-NO-NT	Natural Oak	635-256MB	2	635-160MB	3
VN2DAS-48-WH-NT	White	635-256BG	2	635-160BG	3
VN2DAS-48-BS-NT	Blue Steel	635-256BG	2	635-160BG	3

<p><b>hardware resources</b></p> <p>PROPRIETARY AND CONFIDENTIAL</p> <p>THE INFORMATION CONTAINED IN THIS DRAWING IS THE SOLE PROPERTY OF HARDWARE RESOURCES INC. ANY REPRODUCTION IN PART OR AS A WHOLE WITHOUT THE WRITTEN PERMISSION OF HARDWARE RESOURCES INC. IS PROHIBITED.</p> <p>DO NOT SCALE DRAWING</p>	ITEM#: VN2DAS-48	MATERIAL:	
	FINISH:	WEIGHT: 9	
	TOLERANCE UNLESS OTHERWISE SPECIFIED: X ±0.20 X.X ±0.10 X.XX ±0.05 ANGULAR: ±0.5°	UNITS: DRAWN BY: <i>Hugo.cai</i> APPROVED BY: RELEASE LEVEL:	DATE: Jan-09-23 DATE: REVISION:
	PROJECTION	SHEET:	REVISION:

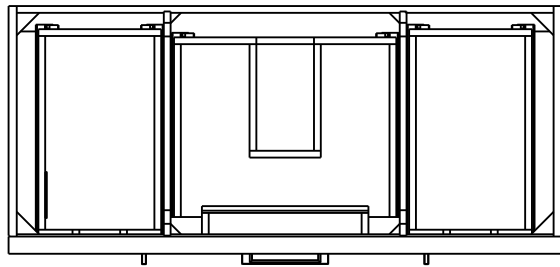
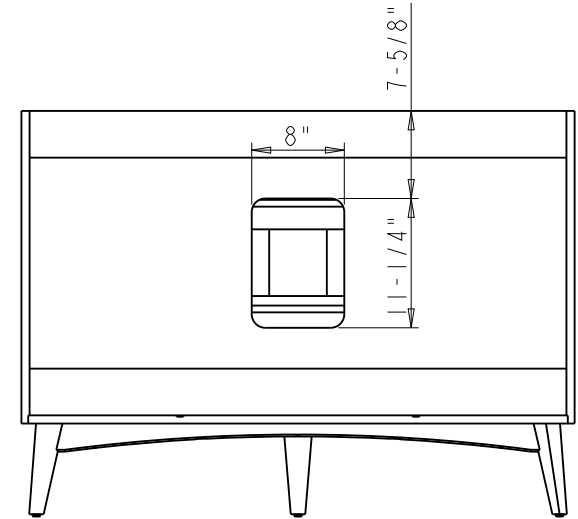
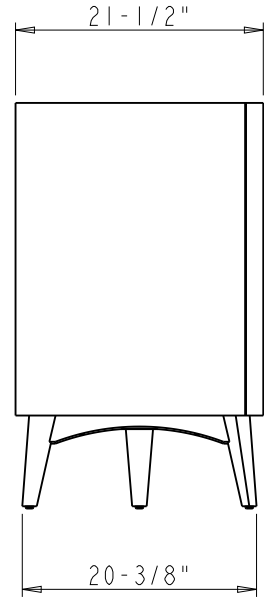
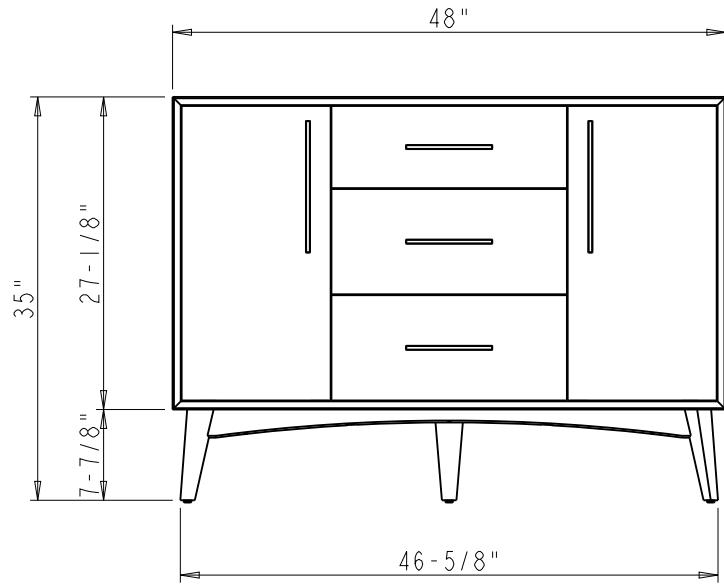

 <p><b>PROPRIETARY AND CONFIDENTIAL</b></p> <p>THE INFORMATION CONTAINED IN THIS DRAWING IS THE SOLE PROPERTY OF HARDWARE RESOURCES INC. ANY REPRODUCTION IN PART OR AS A WHOLE WITHOUT THE WRITTEN PERMISSION OF HARDWARE RESOURCES INC. IS PROHIBITED.</p>	ITEM#: VN2DAS - 48		MATERIAL:		
	FINISH:		WEIGHT: 9		
	TOLERANCE UNLESS OTHERWISE SPECIFIED: X ±0.20 X.X ±0.10 X.XX ±0.05 ANGULAR: ±0.5°		UNITS:	DRAWN BY: <i>Hugo.cai</i>	DATE: Jan-09-23
	DO NOT SCALE DRAWING		SIZE:	APPROVED BY:	DATE:
		SHEET:	RELEASE LEVEL:	REVISION:	



 <p><b>PROPRIETARY AND CONFIDENTIAL</b></p> <p>THE INFORMATION CONTAINED IN THIS DRAWING IS THE SOLE PROPERTY OF HARDWARE RESOURCES INC. ANY REPRODUCTION IN PART OR AS A WHOLE WITHOUT THE WRITTEN PERMISSION OF HARDWARE RESOURCES INC. IS PROHIBITED.</p> <p>DO NOT SCALE DRAWING</p>	ITEM#: VN2DAS - 48	MATERIAL:	
	FINISH:	WEIGHT: 9	
	TOLERANCE UNLESS OTHERWISE SPECIFIED: X ±0.20 X.X ±0.10 X.XX ±0.05 ANGULAR: ±0.5°	UNITS:	PROJECTION 
	DATE: Jan-09-23	DRAWN BY: Hugo.cai	DATE:
	APPROVED BY:	DATE:	
	RELEASE LEVEL:	REVISION:	