









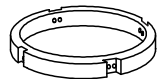
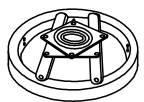

ASSEMBLY INSTRUCTION

943C(SPK) X-BACK SWIVEL COUNTER HEIGHT CHAIR

A Backrest  1pc	B Cushion Seat  1pc	C Footrest  1pc	D Apron With Swivel Plate  1pc	E Chair Leg  4pcs
F Bolt 1/4 x 1"  4pcs	G Bolt 1/4 x 1 - 1/2"  16pcs	H Bolt 1/4 x 1 - 3/4"  6pcs	I Lock Washer 1/4 x 1/2"  26pcs	J Flat Washer 1/4 x 3/4"  16pcs
K Flat Washer 1/4 x 5/8"  10pcs	L Allen Wrench 5/32"  1pc			

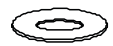

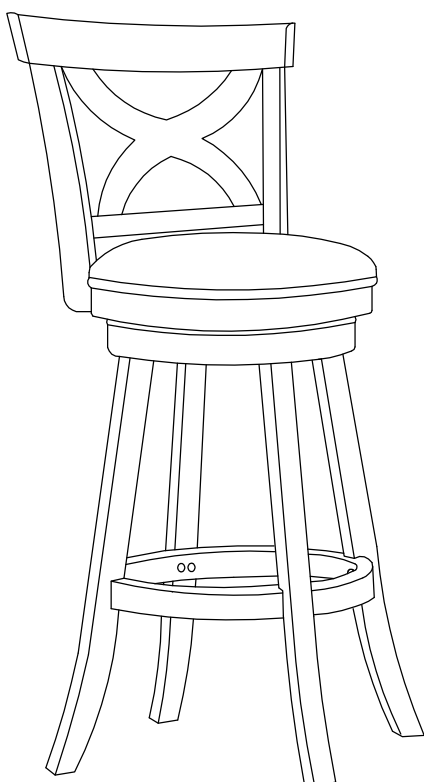
This page lists all the contents included in the box. Please take the time to identify the hardware as well as the individual components to this product. As you unpack and prepare for assembly, place the contents on a carpeted or padded area to protect them from damage.

1

Attached the Chair Legs (E) to the Apron With Swivel Plate (D), then attach the Footrest (C) to the Chair Legs (E). Use Bolt (G), Lock Washer (I), Flat Washer (J) with Allen Wrench (L) for both.

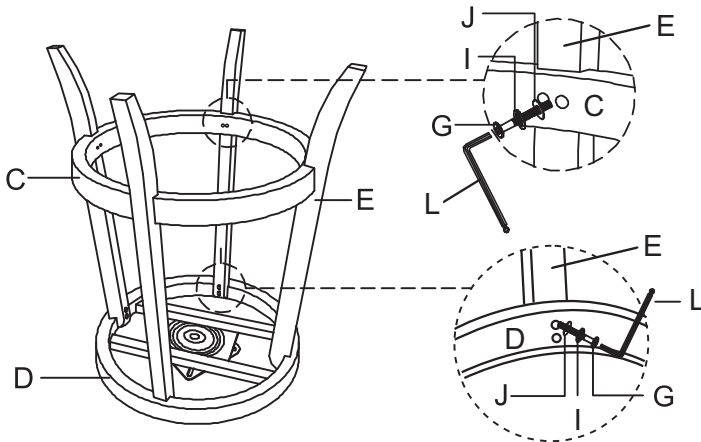

Take the Allen Wrench, and turn the bolts until the legs are secure. **DO NOT TIGHTEN COMPLETELY.** Stop when you feel you are adding force to tighten the bolt.

2

Invert Cushion Seat (B) and place on a stable raised surface (i.e. Table). Attached the Backrest (A) to the Cushion Seat (B) using Bolt (H), Lock Washer (I), Flat Washer (K) with Allen Wrench (L).

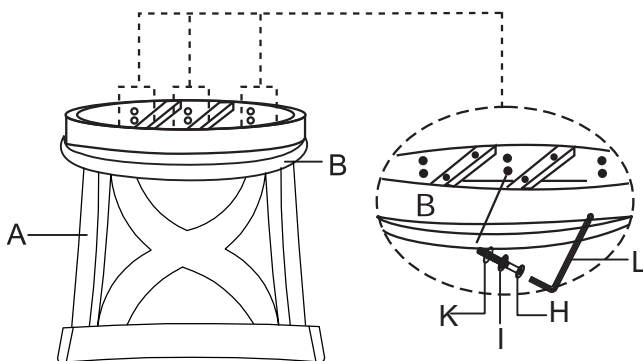
**3**

Keep the Backrest (A) and Cushion Seat (B) inverted on a stable raised surface. Attached the Swivel Plate located on the Apron With Swivel Plate (D) to the Cushion Seat (B) using Bolt (F), Lock Washer (I), Flat Washer (K) with Allen Wrench (L). Turn the Swivel Pub Stool right side up.

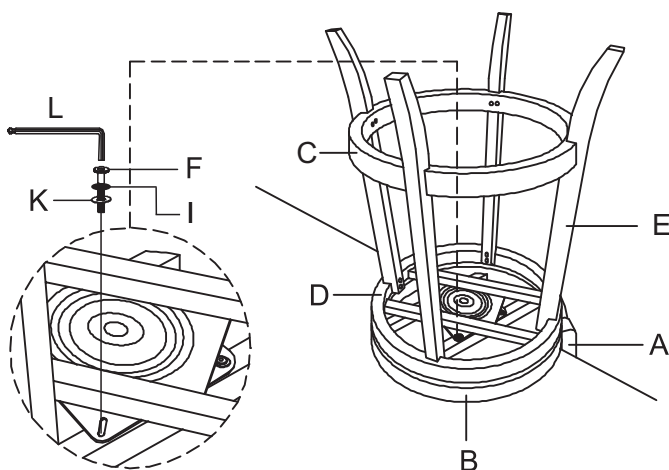

Stand chair up on an even surface and check that it is balanced. If there is a slight wobble, apply downward pressure in the corner where a leg is uneven. Keeping pressure in that corner, tighten all bolts. If balanced, apply downward pressure evenly in the center and tighten all bolts. Do not over-tighten beyond hole depth.

Helpful Tip:

-Instead of applying downward pressure while reaching under to tighten bolts, have someone sit in the chair while you tighten the bolts.

CLEANING & CARE

Treat surface with care. Surface is resistant to scratches but is not scratch resistant. Clean surface with a dry or damp soft cloth. Do not use abrasive cleaners. Hardware may loosen over time. Periodically check that all connections are tight.