

## 5.0 Gallon Straight Sided "Grease" Pail with Tear Skirt Cover

### Product Uses    Product Codes

Grease Products    Pail: **7502,5500 Series, 5556**  
 Silicon Products    Description: 5.0 Gallon 90mil "Grease" Pail  
 Solid Products

Cover: **4580 Series**  
 Description: Tear Skirt "Grease" Cover  
 Note: \*Multiple fitting and venting options available

### Features

UN Rating Solids: Y25  
 Gauge: 90 mil  
 Nominal capacity: 5.0 USG / 19.0 L  
 Maximum capacity: 5.36 USG / 21.2 L  
 Tare Weights:    Body: 2.01 lbs. / 911 g  
                           Cover: 0.61 lbs. / 275 g

### Specifications with Cover

Dimensions: 12-3/8" D. X 13-9/16" H  
 Tare Weight: 2.62 lbs. / 1.19 kg

### Colors

Standard: White, Black and Natural  
 Custom: Available at manufacturer's discretion

### Decorating Options

Four color offset printing  
 Print area: 33"W X 8-1/2"H  
 Sleeve or pressure sensitive labeling  
 Note: \*Where available

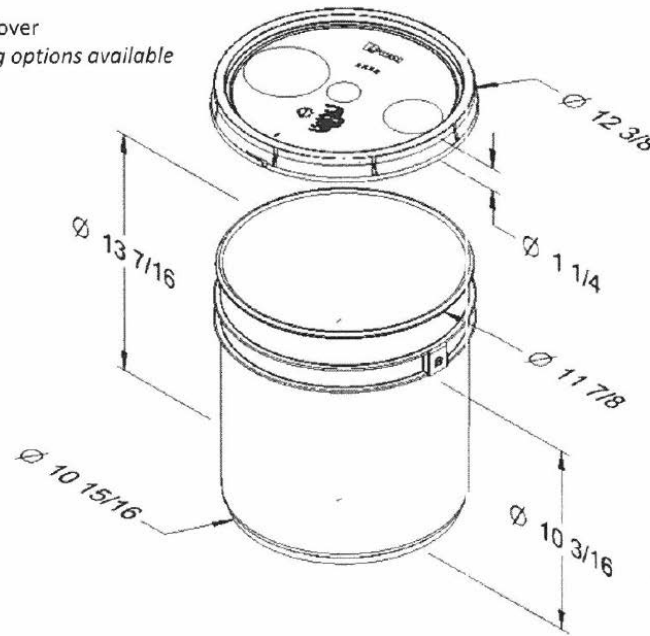

### Shipping Data

Qty. per pallet/carton:	36*
Gross Weight (lbs./kgs.)**:	94/43
Length (in./cm.):	48/122
Width (in./cm.):	36/91.4
Height (in./cm.):	13.50/47

Approximate truckload quantity of 1,008 packages\*\*\*

### Packages

### Filled Containers

36 (36 per layer/1 layers high)  
 Pallet height: 18.5"

### Notes:

\*Quantity can vary based on customer request  
 \*\*Weight does not include pallet/packaging  
 \*\*\*Based on 53' trailer and standard pallet quantities

### Materials

FDA approved materials  
 Resin: Body: High-Density Polyethylene (HDPE) Cover: High-Density Polyethylene (HDPE)  
 Gasket: Ethylene Propylene Diene Monomer (EPDM) Gasket  
 MSDS Sheets available upon request

Optional Carrying Handle – Wire or Plastic

### DISCLAIMER

THIS INFORMATION IS PROVIDED AS A GENERAL GUIDE, INCLUDING DIMENSIONS. IT IS THE CUSTOMER'S RESPONSIBILITIES TO SELECT THE PROPER CONTAINER FOR PRODUCT AND APPLICATION COMPATIBILITY.

DISTRIBUTED BY:



REF NO.:

DWG20614

DESCRIPTION:

5 gallon HDPE Straight Side Pail