





HEKMAN

X A HOWARD MILLER COMPANY

ASSEMBLY INSTRUCTIONS

28514 - Writing Desk H0421-013

NO.	Hardware List		Q'ty
A		Bolt 5/16" * 45mm L	8
B		Lock Washer 5/16" Dia	8
C		Flat Washer 5/16" Dia	8
D		Wrench 3/16" Dia*4-3/4" L	1
E		Screw 8 x 1 1/2"	2

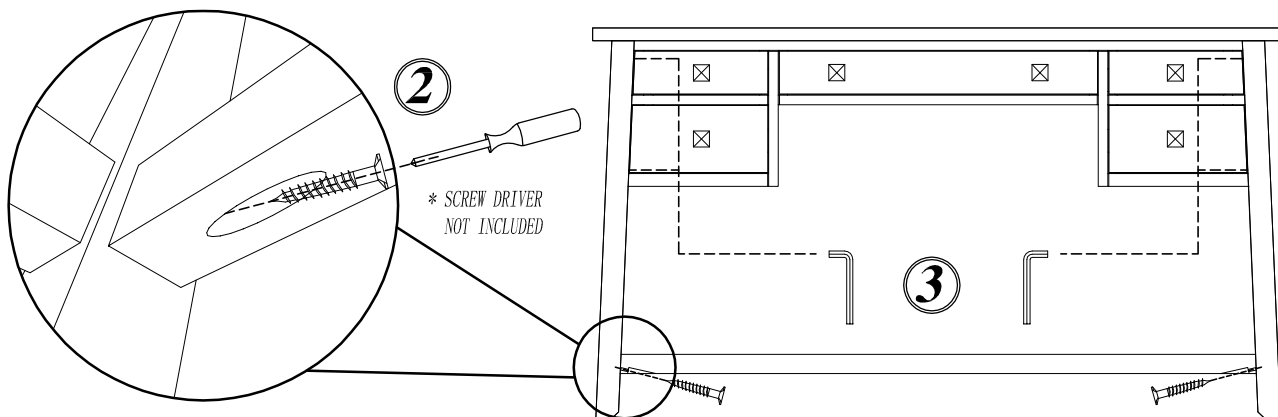
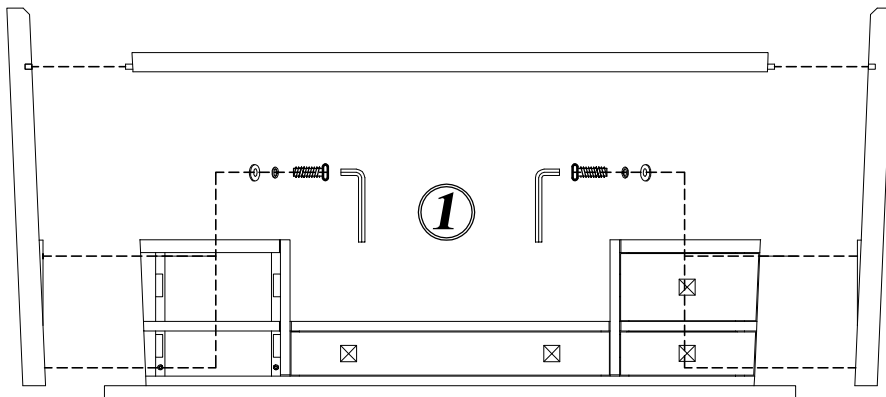

PLACE THE TOP ASSEMBLY UPSIDE DOWN ON SOFT AND CLEAN SURFACE TO PREVENT SCRATCHING

1. ASSEMBLE THE TOP ASSEMBLY WITH THE LEFT AND RIGHT LEG ASSEMBLIES USING BOLT (A), LOCK WASHER (B), FLAT WASHER (C), USING WRENCH (D), BUT DO NOT TIGHTEN THE BOLTS COMPLETELY AT THIS TIME.
2. ASSEMBLE THE STRECHER, TIGHTEN USING SCREW (E), USE PHILIP SCREW DRIVER.
3. TIGHTEN ALL THE BOLTS

MADE IN INDONESIA