

SECTION A-A

THREAD DETAIL:  
6 THREADS PER INCH, 0.167" PITCH

REFERENCE	TOLERANCE	UNITS	DIMENSION
E	$\pm 0.015$ [0.38]	in [mm]	2.138 [54.30]
T	$\pm 0.015$ [0.38]	in [mm]	2.235 [56.77]
H	$\pm 0.010$ [0.25]	in [mm]	0.400 [10.16]
OAH	$\pm 0.012$ [0.30]	in [mm]	0.489 [12.42]
OD	$\pm 0.015$ [0.38]	in [mm]	2.353 [59.76]
PART WEIGHT	$\pm 1.50$	g	6.00

DISCLAIMER

THIS INFORMATION IS PROVIDED AS A GENERAL GUIDE, INCLUDING DIMENSIONS. IT IS THE CUSTOMER'S RESPONSIBILITIES TO SELECT THE PROPER CONTAINER FOR PRODUCT AND APPLICATION COMPATIBILITY.

DISTRIBUTED BY:



REF NO.:

DWG32001

DESCRIPTION:

58-400 PP Matte Top, Ribbed Sides Cap with F217 Liner

CRITICAL FOR ORIENTATION  
 .001" = 2 Degrees in Change  
 S' 0.133 [3.38]

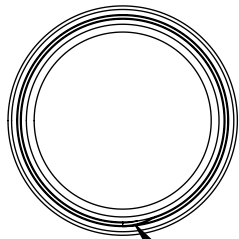
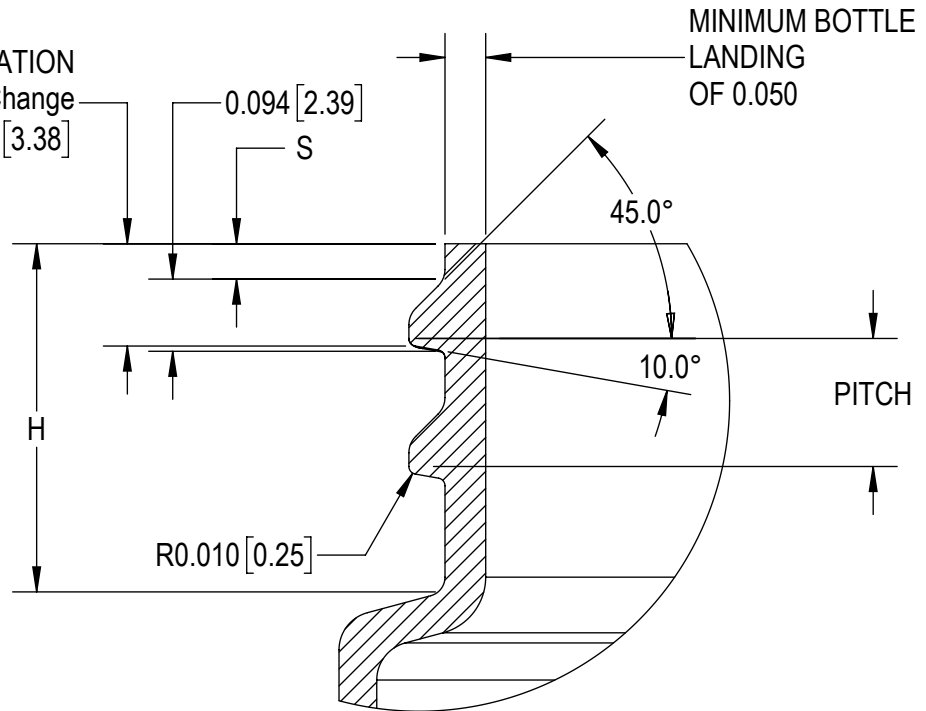

THREAD START

DETAIL THREAD  
 SCALE 4 : 1

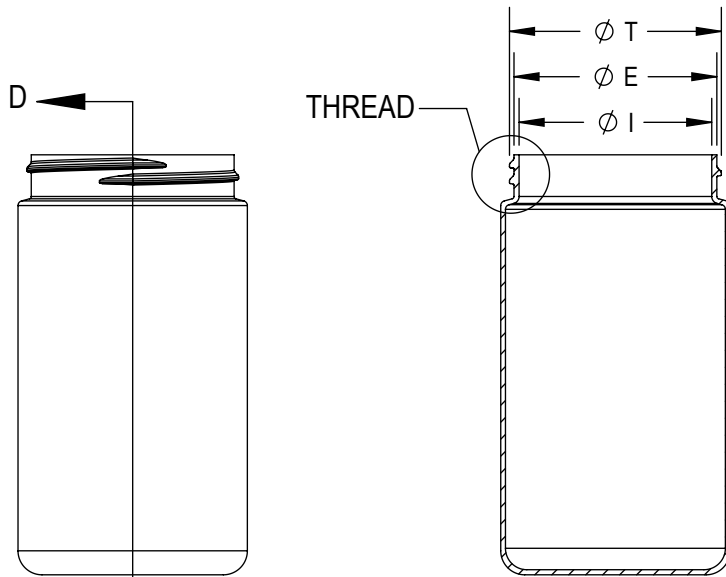

SECTION D-D

REFERENCE	TOLERANCE	UNITS	DIMENSIONS
E	±0.017 [0.43]	in [mm]	2.113[53.67]
T	±0.017 [0.43]	in [mm]	2.207[56.07]
I	MINIMUM	in [mm]	1.974 [50.14]
S	±0.015 [0.38]	in [mm]	0.046[1.17]
H	±0.015 [0.38]	in [mm]	0.408[10.36]
TPI			6
PITCH		in	0.167

DISCLAIMER

THIS INFORMATION IS PROVIDED AS A GENERAL GUIDE, INCLUDING DIMENSIONS. IT IS THE CUSTOMER'S RESPONSIBILITIES TO SELECT THE PROPER CONTAINER FOR PRODUCT AND APPLICATION COMPATIBILITY.

DISTRIBUTED BY:



REF NO.:

DWG32001

DESCRIPTION:

58-400 PP Matte Top, Ribbed Sides Cap with F217 Liner

# F-217®

- F-217® is a coextruded primary liner consisting of a foamed Low-Density Polyethylene (LDPE) core with solid Low-Density Polyethylene (LDPE) layers on both sides.
- Does not promote microbial growth.

## Typical Product Attributes

### Construction

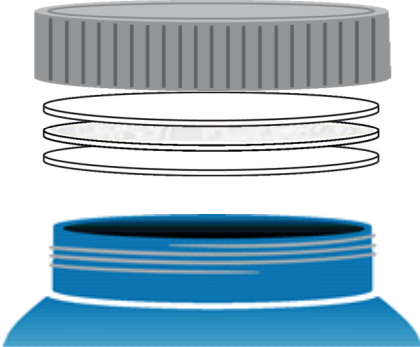
Solid LDPE Foamed LDPE Solid LDPE		SI (µm)  Total Thickness 508 – 3175	US (mils)  Total Thickness 20 - 125
---	--	--	--

### Properties

Color Opacity Density 508 – 762 µm   20 – 30 mil 889 – 3175 µm   35 – 125 mil Thickness Tolerance 508 – 1524 µm   20 – 60 mil 1650 – 2290 µm   65 – 90 mil 2410 – 3180 µm   95 – 125 mil Available Widths 508 – 1520 µm   20 – 60 mil 1650 – 3180 µm   65 – 125 mil Width Tolerance		White or as specified Opaque  480 ± 30 kg/m <sup>3</sup> 400 ± 30 kg/m <sup>3</sup>  ± 127 µm ± 178 µm ± 254 µm  25 – 1016 mm 25 – 228 mm ± 1,6 mm	White or as specified Opaque  30 ± 2 lb./ft <sup>3</sup> 25 ± 2 lb./ft <sup>3</sup>  ± 5 mil ± 7 mil ± 10 mil  1 – 40 in 1 – 9 in ± 0.0625 in
---	--	--	---

### Regulatory Compliance

FDA Compliance  Drug Master File (DMF) Other Compliances  Safety Data Sheet (SDS) Statement	21 CFR 177.1520 Olefin polymers. 21 CFR 177.1210 Closures with sealing gaskets for food containers. 002434 USFDA Food Allergen Guidelines   California Proposition 65 Labeling Requirements   Limitations of Heavy Metals in Packaging per CONEG & EU 94/62/EC, Article 11   Meets the compositional requirements of Regulation (EU) 10/2011 on plastic materials and articles intended to come into contact with food Safety Data Sheets (SDS) are not required for articles as defined in 29 CFR 1910.1200, the OSHA Hazard Communication Standard (HazCom). This product is an article as defined by HazCom and is not considered to be, or to contain, a hazardous chemical based on evaluations made by our company.
--	---

Please note that construction does not reflect adhesive or resin bonding layers, if present.

VERSION	9	DATE	2021-07-26
---------	---	------	------------

DISCLAIMER

THIS INFORMATION IS PROVIDED AS A GENERAL GUIDE, INCLUDING DIMENSIONS. IT IS THE CUSTOMER'S RESPONSIBILITIES TO SELECT THE PROPER CONTAINER FOR PRODUCT AND APPLICATION COMPATIBILITY.

DISTRIBUTED BY:



REF NO.:

DWG32001

DESCRIPTION:

58-400 PP Matte Top, Ribbed Sides Cap with F217 Liner