

FINISH DETAIL  
SCALE 2:1  
M38-400 FINISH  
6 T.P.I., 1.0 FULL TURNS

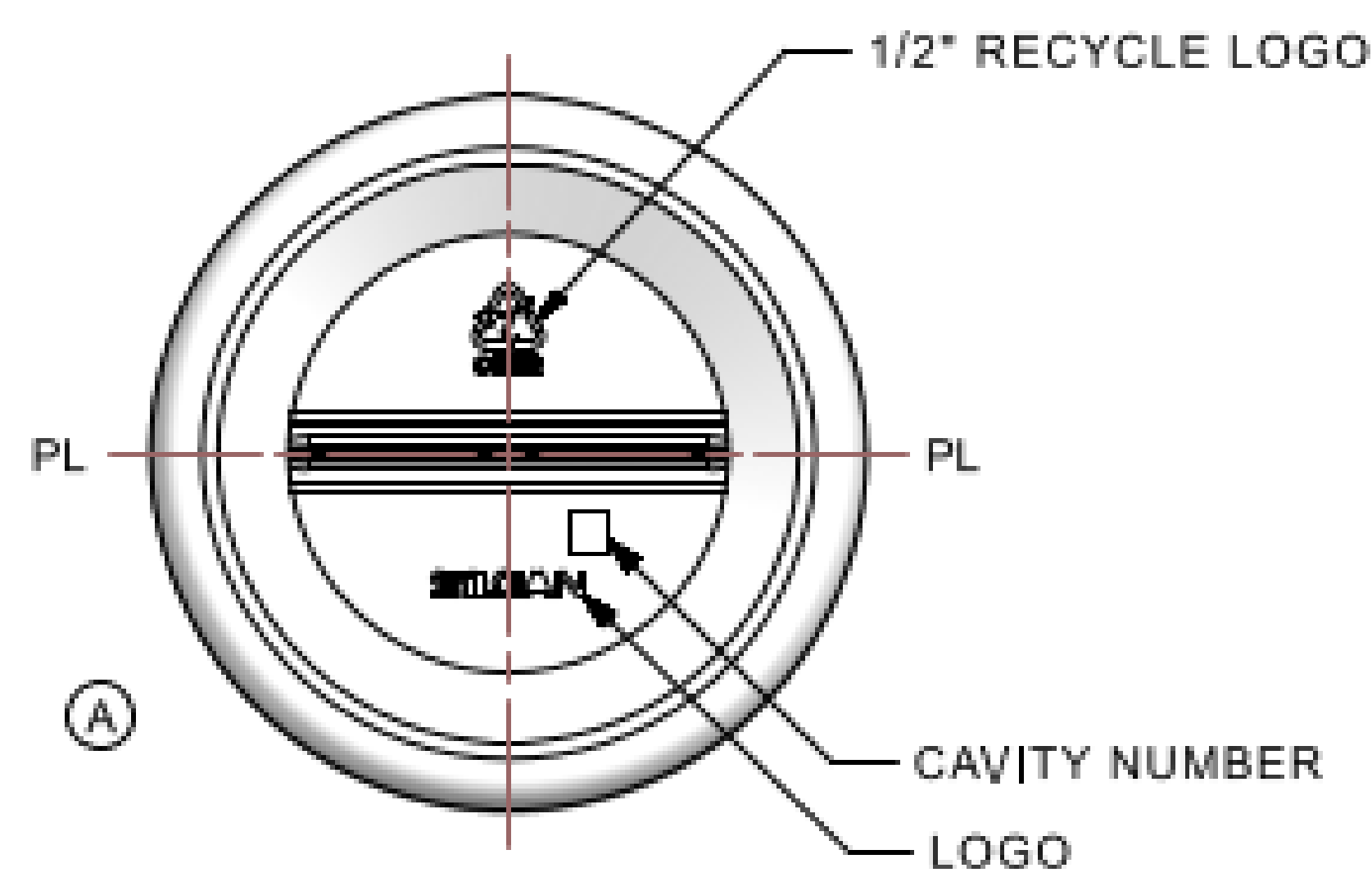

OVERFLOW CAPACITY:	<b>17.48 ± .37 FL.OZ.</b> <b>(516.8 ± 11.0 ML.)</b>
WEIGHT:	<b>42.0 ± 2.5 GRAMS</b>

**DISCLAIMER**

THIS INFORMATION IS PROVIDED AS A GENERAL GUIDE, INCLUDING DIMENSIONS. IT IS THE CUSTOMER'S RESPONSIBILITIES TO SELECT THE PROPER CONTAINER FOR PRODUCT AND APPLICATION COMPATIBILITY.

DISTRIBUTED BY:



REF NO.:

DWG31659

DESCRIPTION:

16 oz HDPE Plastic Barrier Modern Round Bottle, 38-400, 51 Gram