

namesake

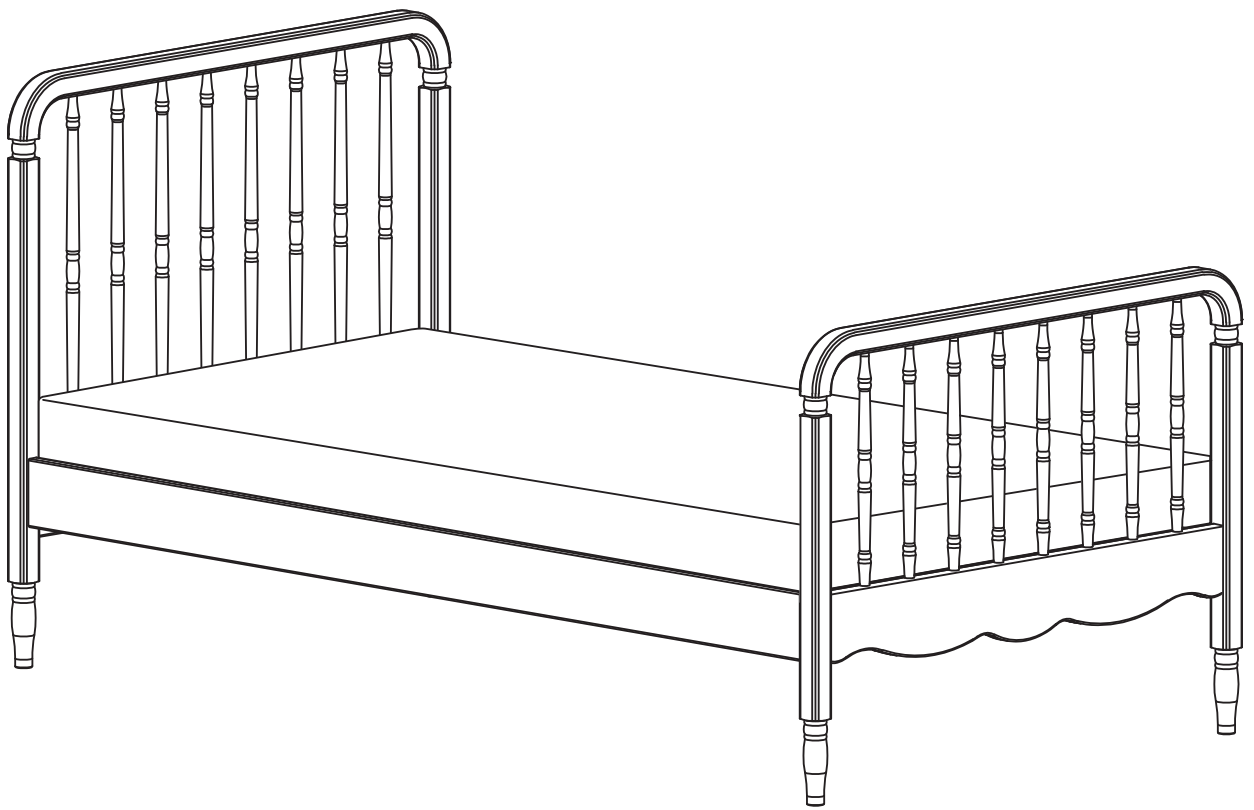

Liberty

M7169



Welcome to Your Next Chapter



We've thoughtfully designed and crafted each piece to grow with your family for years to come.

Here's to new memories of bedtime stories, sleepy snuggles, morning routines, and celebrating milestones big and small.

From our family to yours,
Namesake

Bienvenido a tu próximo capítulo



Hemos diseñado y elaborado cuidadosamente cada pieza para que crezca con tu familia durante años.

Brindemos por nuevos recuerdos de cuentos para dormir, arrumacos para dormir, rutinas matutinas y celebraciones de grandes y pequeños hitos.

De nuestra familia a la tuya,
Namesake

Bienvenue dans votre prochain chapitre



Chaque pièce a été conçue et fabriquée avec soin pour accompagner votre famille pendant de nombreuses années.

Nous vous souhaitons de nouveaux souvenirs : histoires du soir, câlins tout doux, rituels du matin et célébration des petits et grands moments.

De notre famille à la vôtre,
Namesake

GETTING
STARTED

PARA
COMENZAR

POUR
COMMENCER

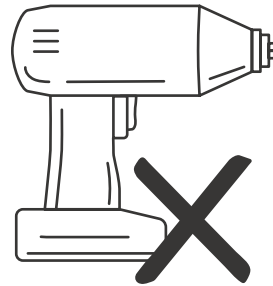
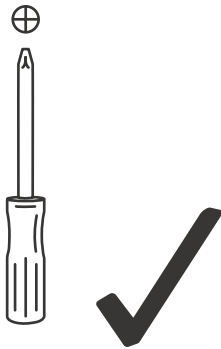
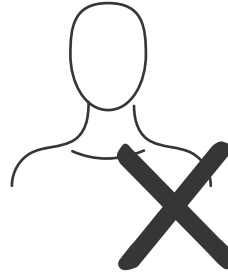
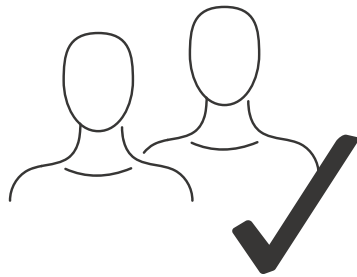

As always, for additional questions, please
contact us and we'll be more than willing to help!



Como siempre, si tuviera preguntas adicionales, ¡póngase en
contacto con nosotros y estaremos complacidos de ayudarlo!



Comme toujours, pour des questions supplémentaires,
contactez-nous et nous serons plus que disposés à vous aider!

[NAMESAKEHOME.COM/SUPPORT](https://www.namesakehome.com/support)
(323) 909-5019

PARTS
NOT TO SCALE

PIEZAS
NO A ESCALA

PIÈCES
NON DESSINÉES À L'ÉCHELLE

A

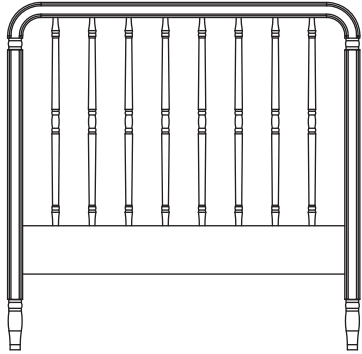

HEADBOARD
CABECERO
TÊTE DE LIT

B

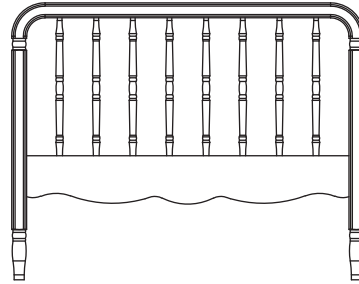

FOOTBOARD
CAMPO DE PIE
PIED DE LIT

C

x2

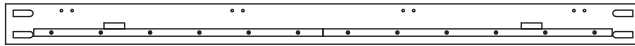

SIDE RAIL
RIEL LATERAL
RAIL LATÉRAL

D

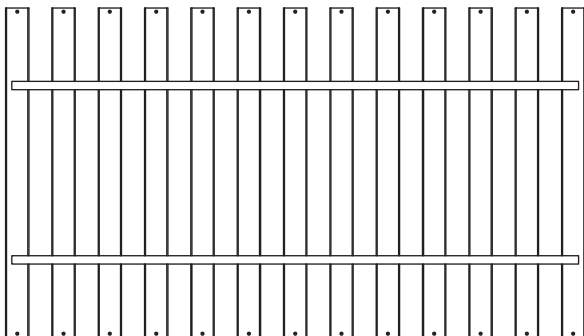

SLAT
LAMA
LATTE

HARDWARE
ACTUAL SIZE

HERRAJE
TAMAÑO REAL

MATÉRIEL
TAILLE ACTUELLE

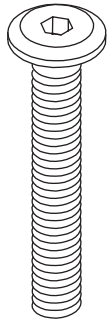

1-1/2" AHB

H1
x8

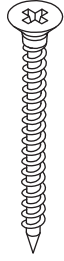

1-1/4" WS

H2
x26



LW

H3
x8

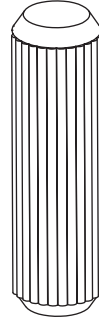

1.2 x 4 cm WD

H4
x4

* Both Allen Wrench (AWR) and Allen Driver (AD) are usable in assembly steps.

* Tanto la llave Allen (AWR) como el destornillador Allen (AD) se pueden utilizar en los pasos de montaje.

* La clé Allen (AWR) et le tournevis Allen (AD) sont tous deux utilisables dans les étapes d'assemblage.

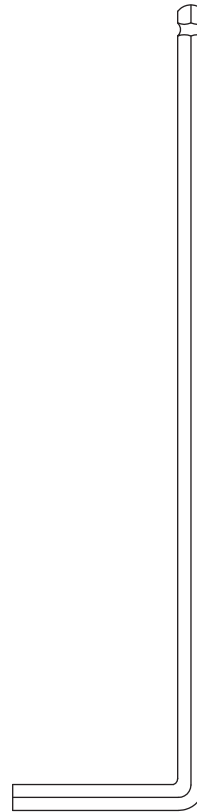

AWR

H5
x1

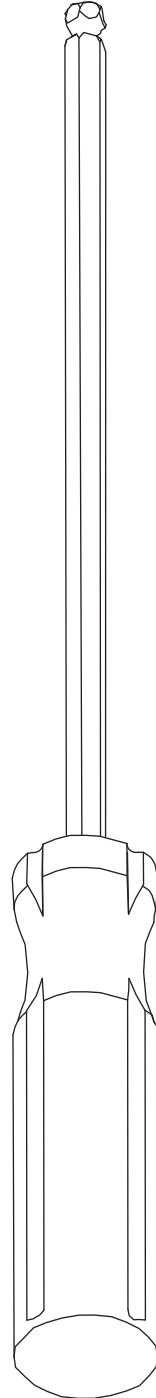

AD

H6
x1

1

H4
x4

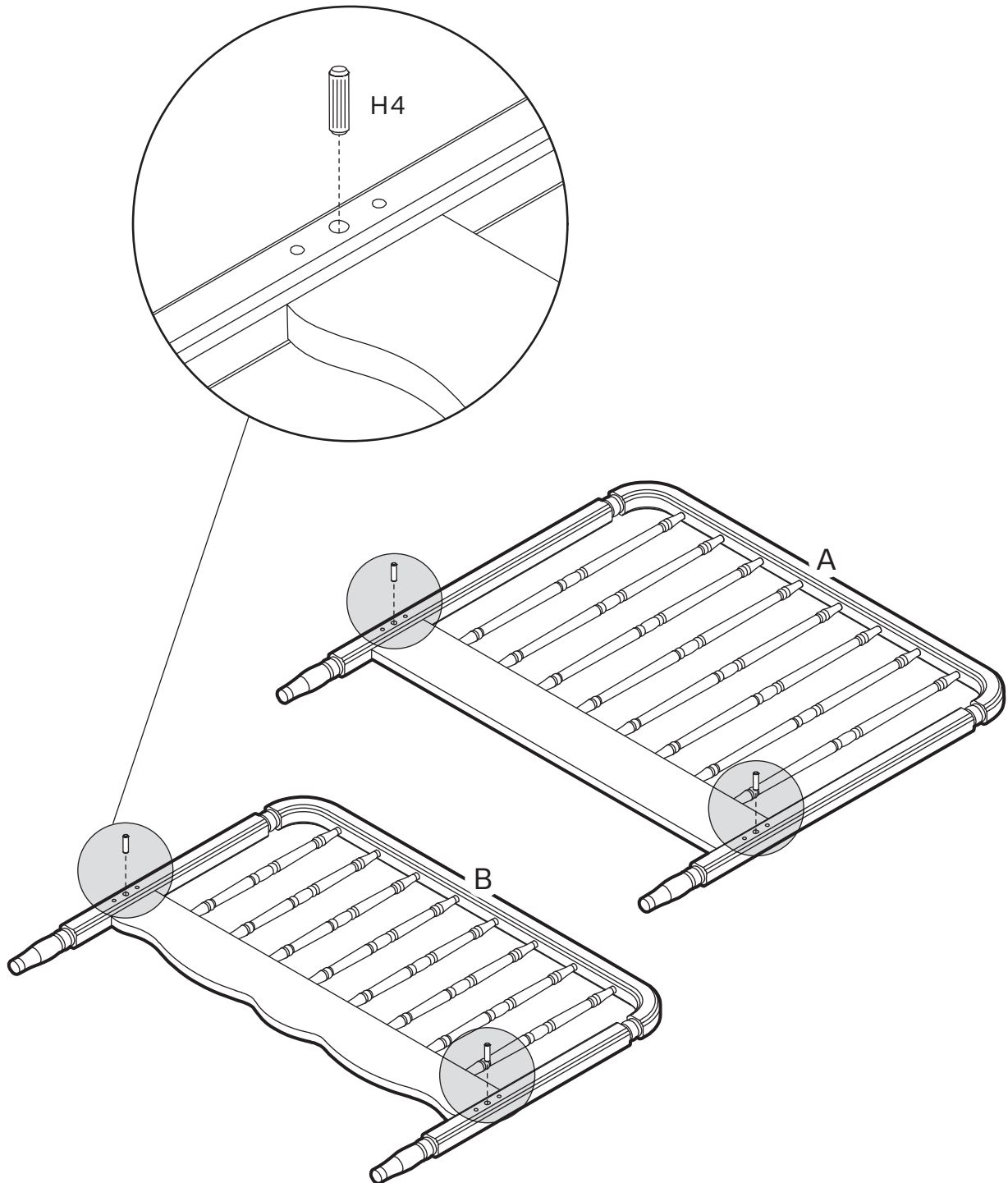
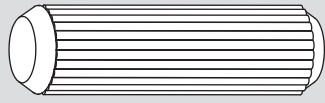

2

H1
x2

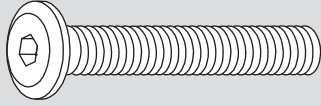

H3
x2

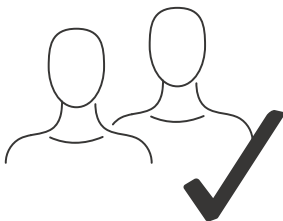
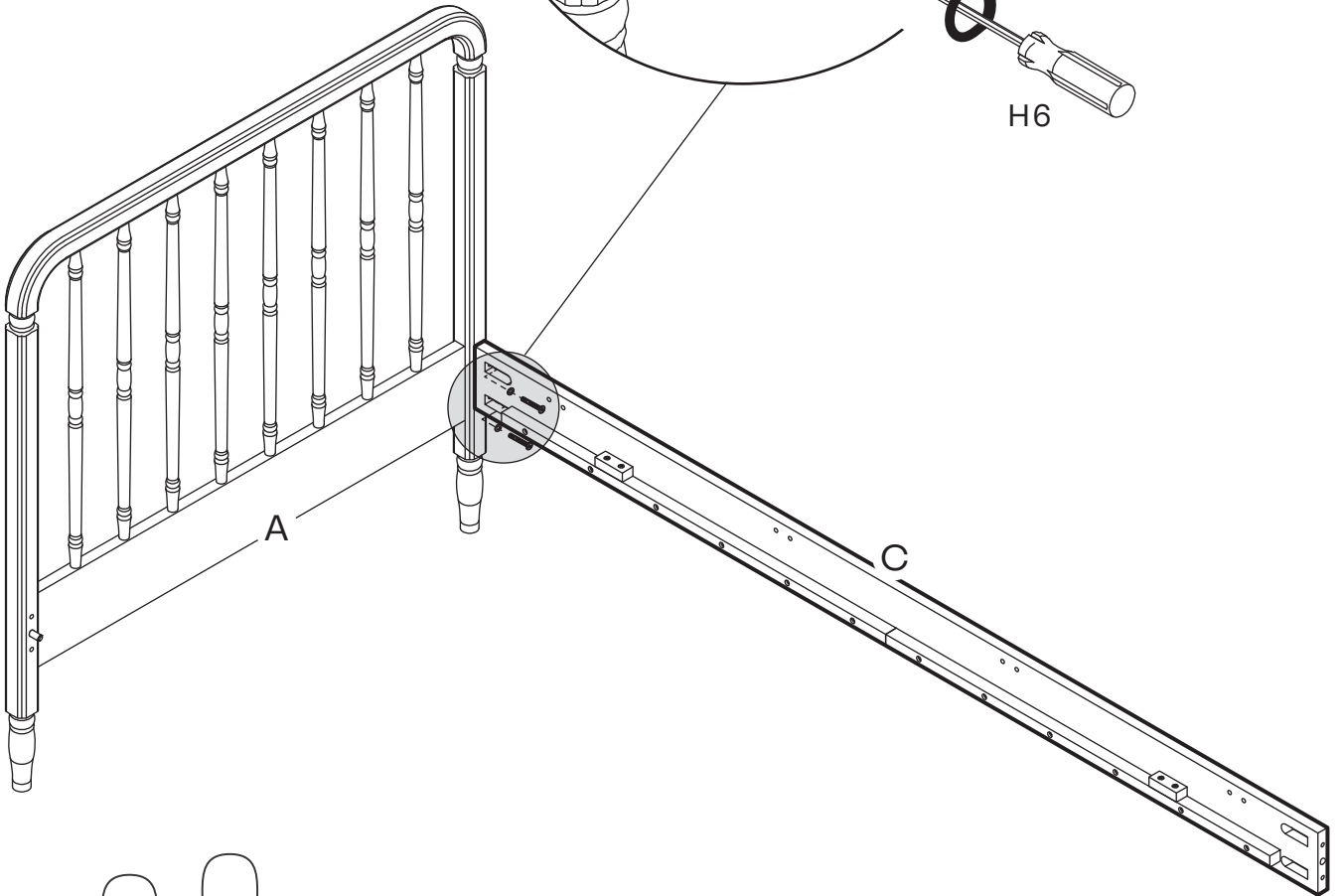
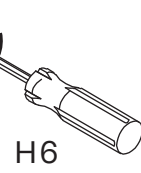
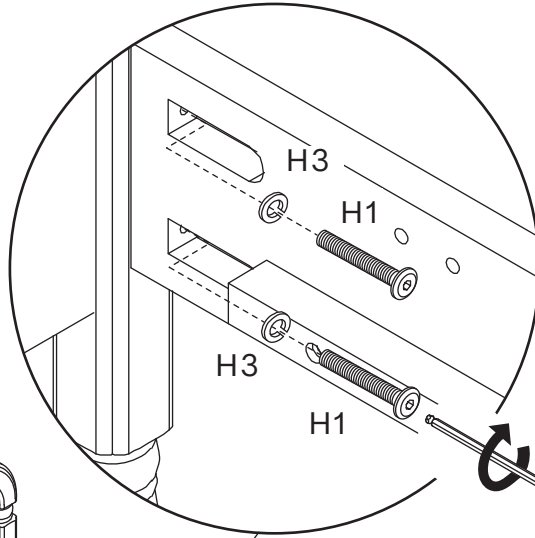

3

H1
x2

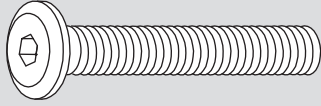

H3
x2

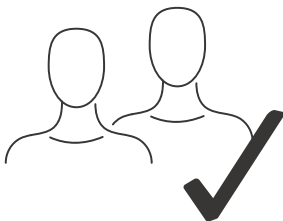
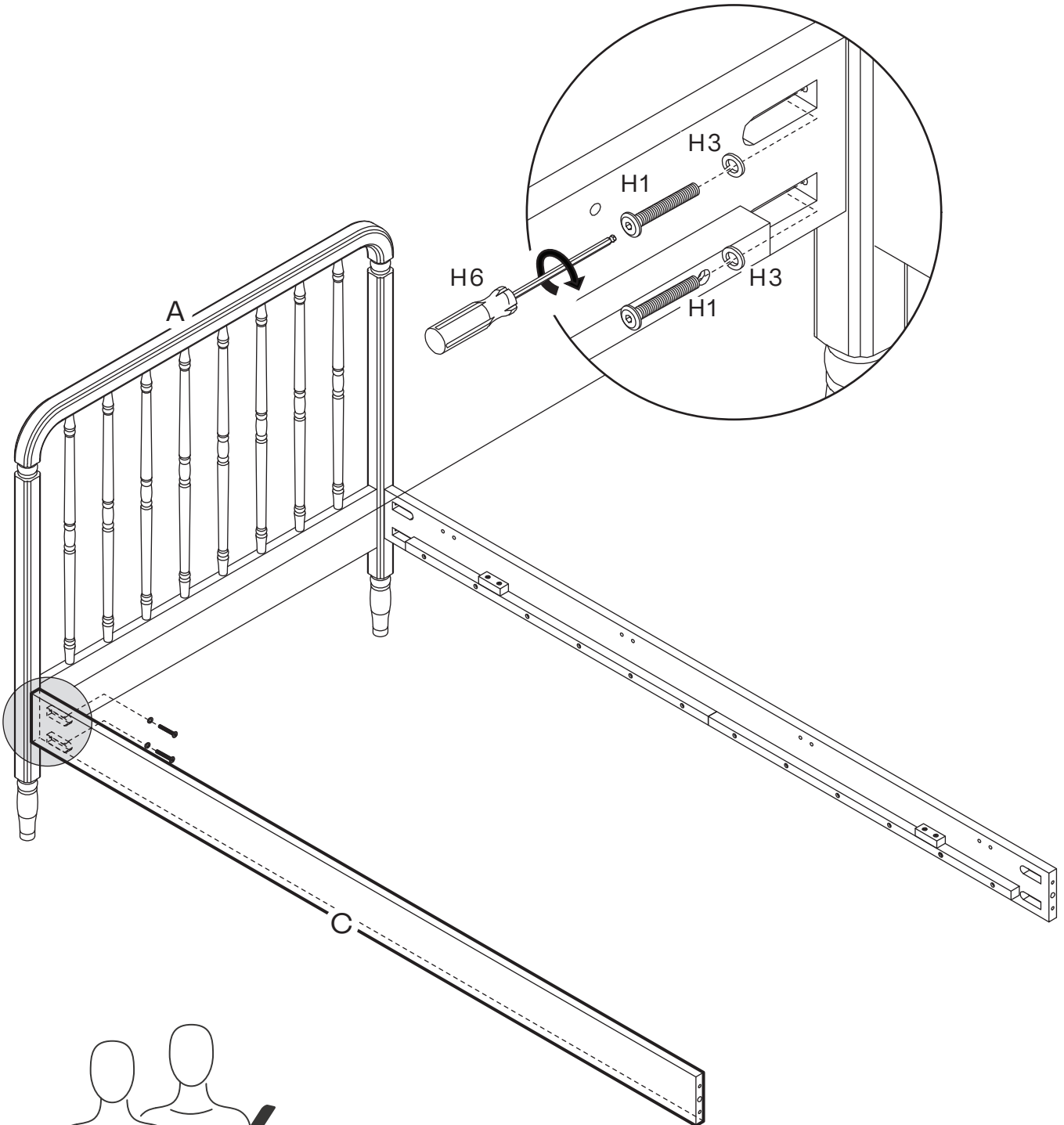

4

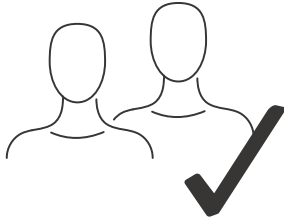

Lift up the side rails (C) from the ends when assembling the footboard (B).

Levante los largueros laterales (C) desde los extremos al ensamblar el piecero (B).

Soulevez les longerons (C) par leurs extrémités lors de l'assemblage du pied de lit (B).

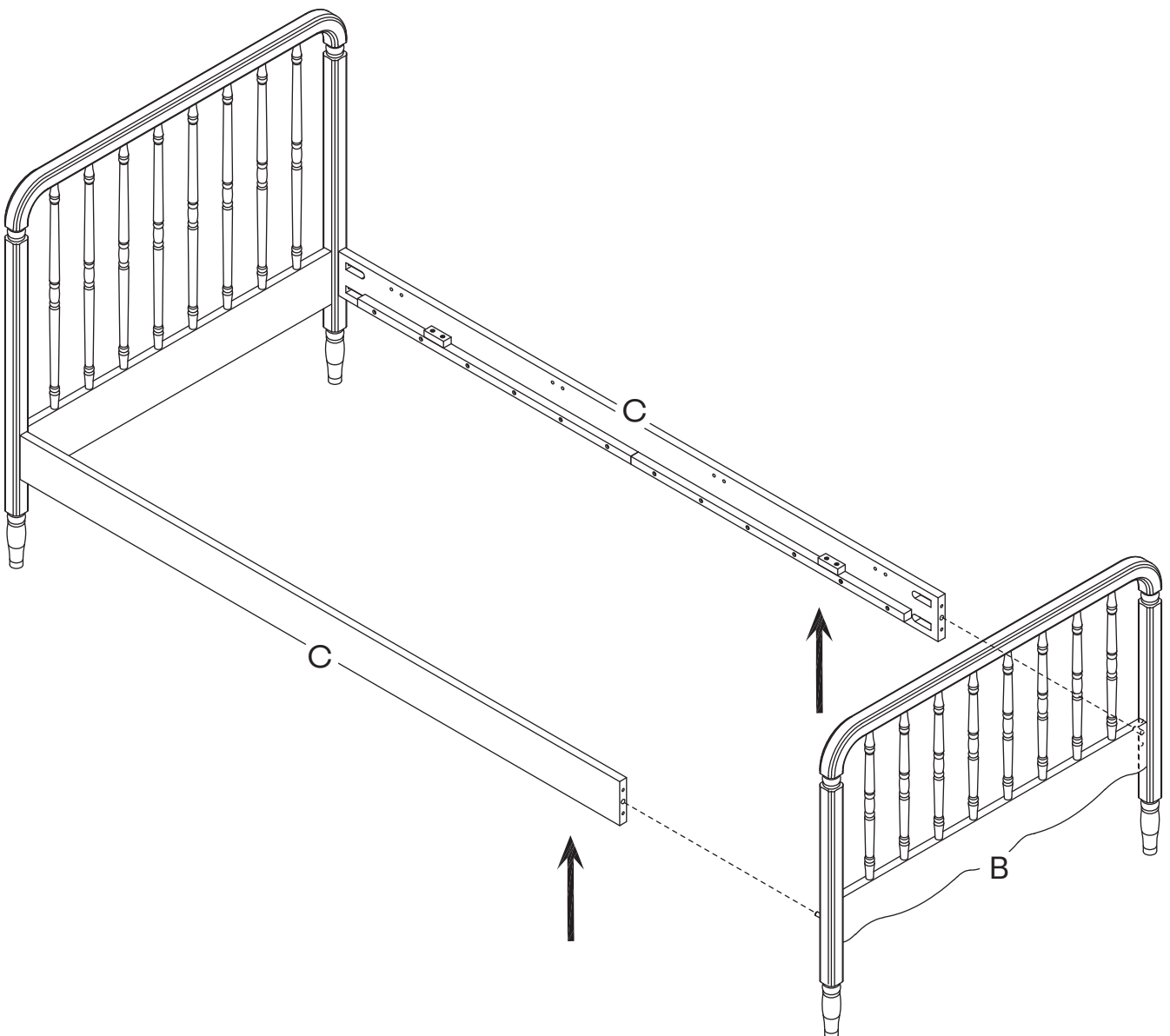

5

H1
x4

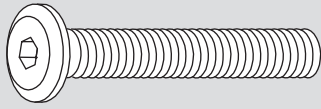

H3
x4

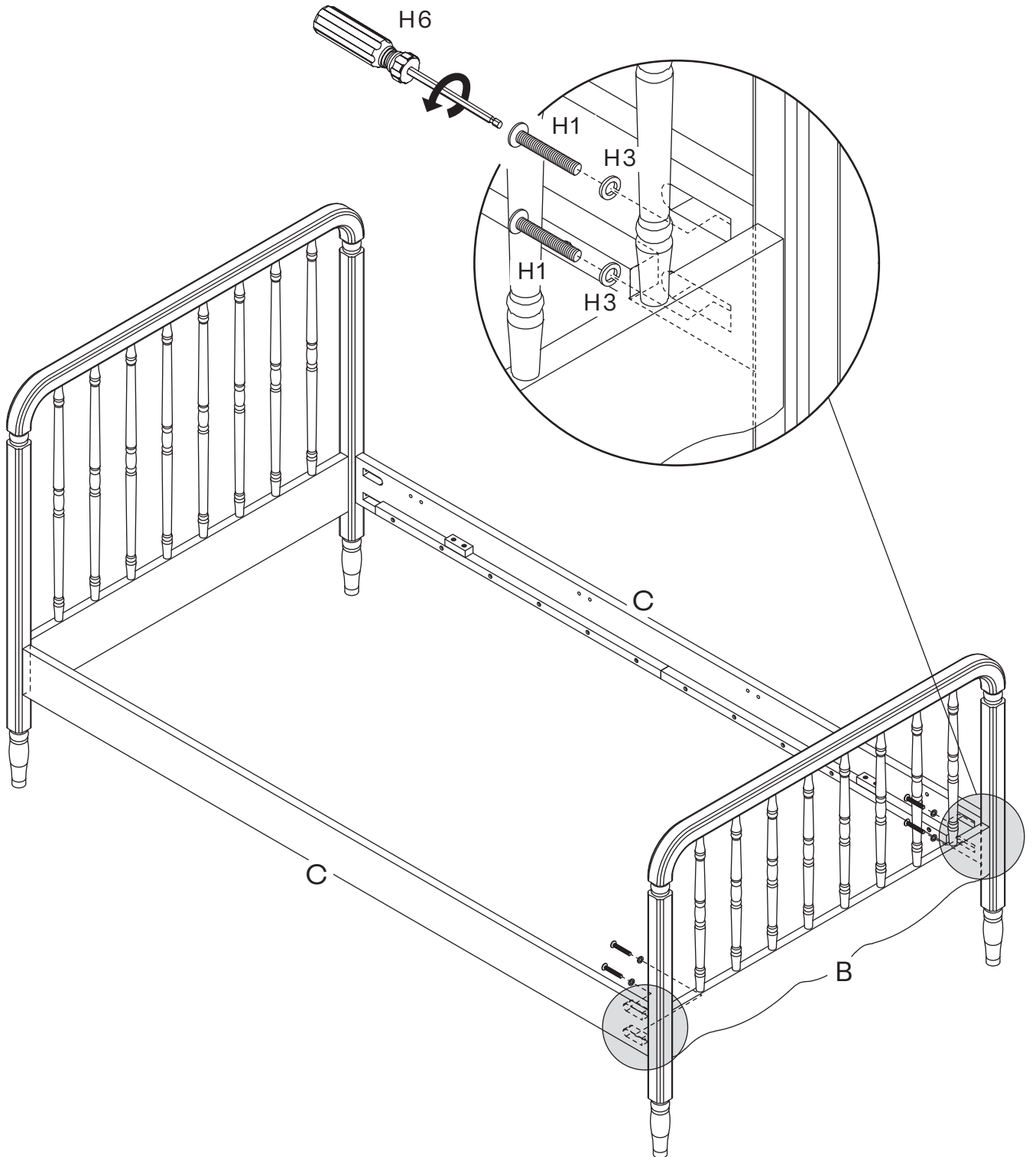

6

H2
x26

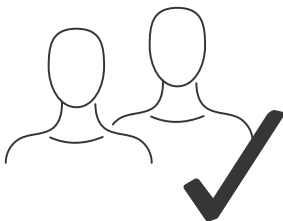
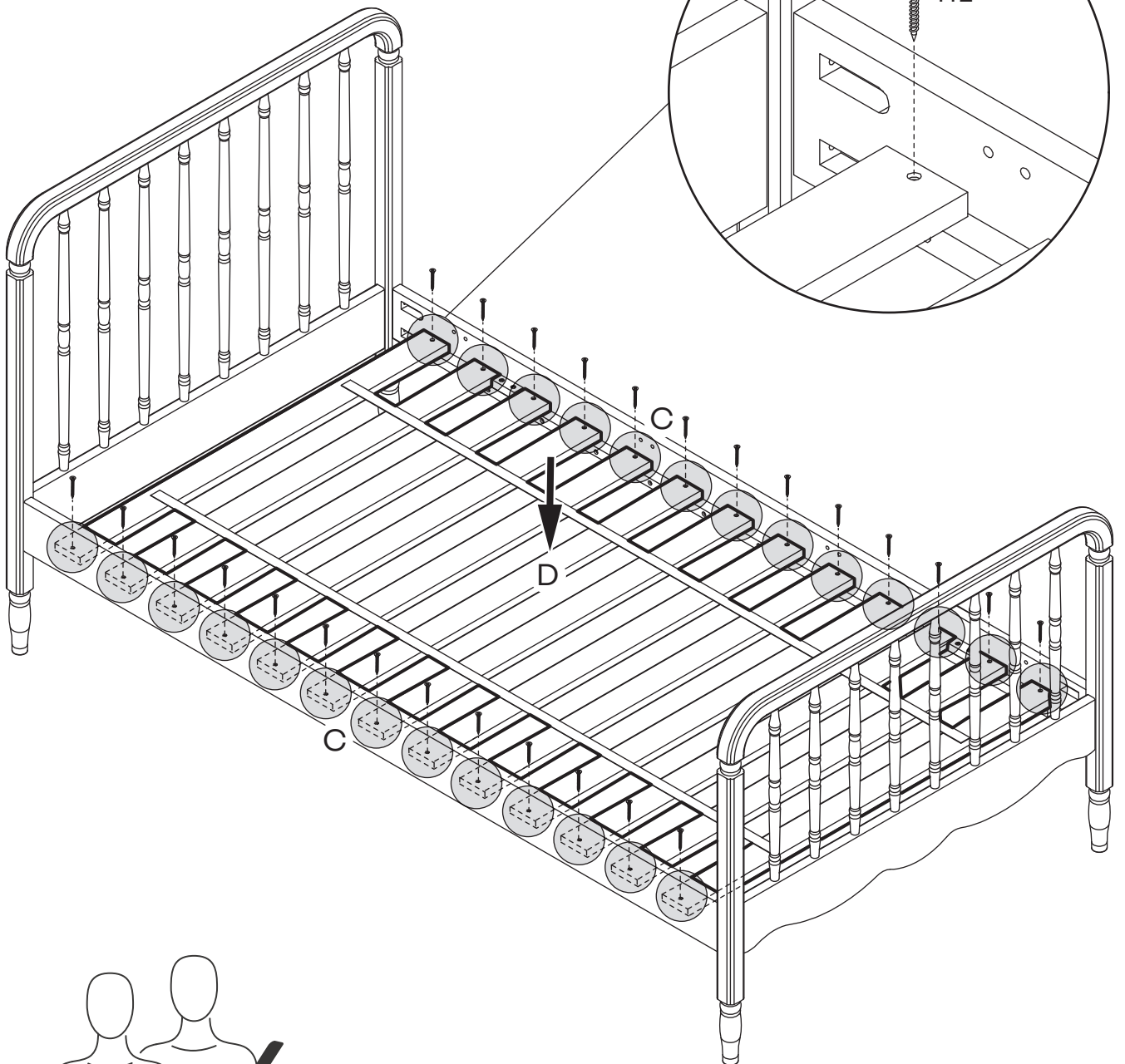
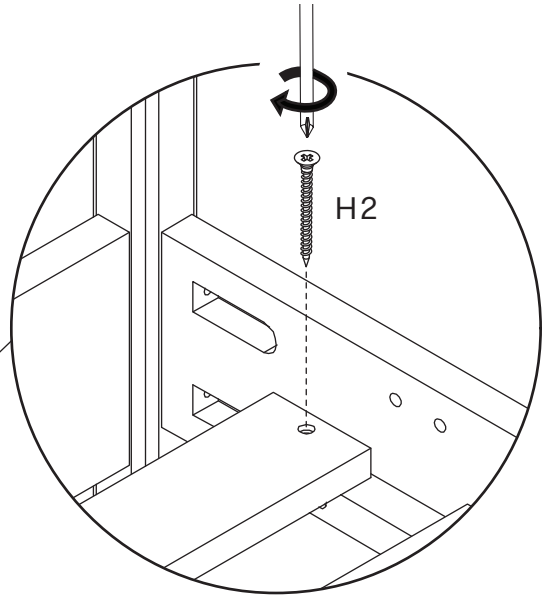
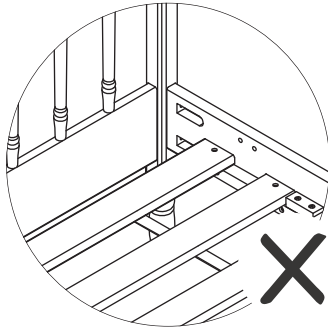
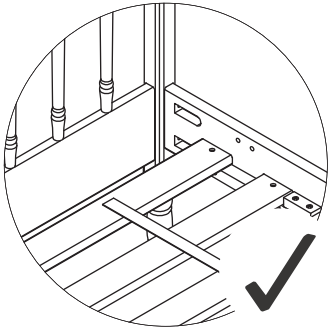
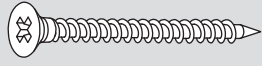

WELCOME HOME



¡LE DAMOS LA BIENVENIDA A CASA!



BIENVENUE À LA MAISON

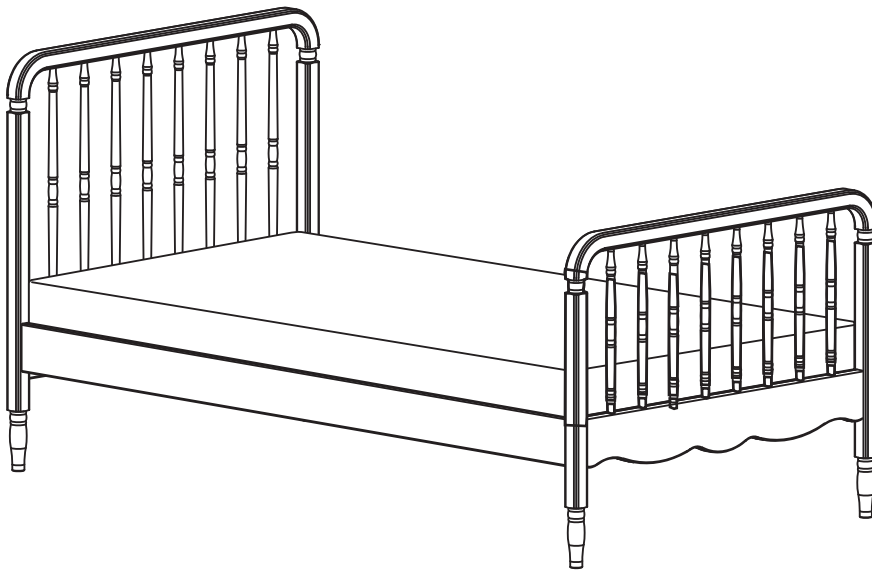

Recommended mattress size :
L74-75" x W38-38.5" x H7.5-9"
(L188-190.5 cm x W96.5-97.8 cm x H19-22.9 cm).

Weight Limit: 350 lbs (159 kg).
Age range: 3 yrs old+.

•
Tamaño de colchón recomendado:
L188-190.5 cm x W96.5-97.8 cm x H19-22.9 cm
(L74-75pulg. x W38-38.5pulg. x H7.5-9pulg.).

Límite de peso: 159 kg (350 lbs).
Edad recomendada: 3 años.

•
Taille de matelas recommandée :
L188-190,5 cm x W96,5-97,8 cm x H19-22,9 cm
(L74-75 po x W38-38,5 po x H7,5-9 po).

Limit de poids: 159 kg (350 livres).
Tranche d'âge: 3 ans+.

WARNING

- Always use the recommended size mattresses or mattress supports, or both, to help prevent the likelihood of entrapment or falls.
- Periodically check and ensure that the guardrail, ladder, and other components are in their proper position, free from damage, and that all connectors are tight.
- Do not allow horseplay on or under the bed and prohibit jumping on the bed.
- Do not use substitute parts. Contact the manufacturer or dealer for replacement parts.
- The use of water or sleep flotation mattresses is prohibited.
- Keep these instructions for future reference.



ADVERTENCIA

- Utilice siempre colchones o soportes de colchón del tamaño recomendado, o ambos, para evitar atrapamientos o caídas.
- Revise periódicamente y asegúrese de que la barandilla, la escalera y demás componentes estén en su posición correcta, sin daños y de que todos los conectores estén bien apretados.
- No permita que los niños jueguen bruscamente sobre la cama ni debajo de ella, ni que salten sobre ella.
- No utilice piezas de repuesto. Para obtener piezas de repuesto, póngase en contacto con el fabricante o el distribuidor.
- Queda prohibido el uso de colchones de agua o de flotación para dormir.
- Conserve estas instrucciones para futuras consultas.



AVERTISSEMENT

- Utilisez toujours des matelas ou des sommiers de la taille recommandée, ou les deux, pour éviter tout risque de coincement ou de chute.
- Vérifiez régulièrement que la barrière de sécurité, l'échelle et les autres composants sont correctement positionnés, en bon état et que tous les connecteurs sont bien serrés.
- Interdisez les jeux violents sur ou sous le lit et interdisez de sauter dessus.
- N'utilisez pas de pièces de rechange. Contactez le fabricant ou le revendeur pour obtenir des pièces de rechange.
- L'utilisation de matelas à eau ou de matelas flottants est interdite.
- Conservez ces instructions pour référence ultérieure.

REGISTRATION

Registering your product is simple.
NAMESAKEHOME.COM/REGISTRATIONS



PART REPLACEMENT

If you would like to order replacement or missing parts, please visit us at,
NAMESAKEHOME.COM/PARTS

or you can contact us by mail at,
8500 REX RD. PICO RIVERA, CA 90660



ONE YEAR LIMITED WARRANTY

Rest assured, your Namesake product is covered under
warranty for one year after the date of purchase. For more details on our
warranty policy, please visit,

NAMESAKEHOME.COM/WARRANTY



CARE AND CLEANING

To clean wood or metal parts, use a lint-free, soft cloth with a non-toxic
cleaner. Wipe dry immediately. To avoid scratches or other damages, do not
use abrasive chemicals or materials. For fabrics, we recommend using a
non-toxic foaming fabric cleaner or leather cleaner where appropriate.

Touch up kits are available for purchase by contacting us at,
(323) 909-5019 OR NAMESAKEHOME.COM/PARTS



STORAGE

Because materials respond to temperature and humidity, it is important to store
furniture in controlled environments. Furniture should not be placed in direct
sunlight or near air-conditioning outlets, radiators, heaters, or humidifiers. Any
changes such as extreme heat or cold, dampness, or dryness, may cause notice-
able shrinkage or swelling of wood. Direct sunlight may affect the coloring of
materials over time.

REGISTRARSE

Es sencillo registrar su producto.

NAMESAKEHOME.COM/REGISTRATIONS



RECAMBIO DE PIEZAS

Si quisiera pedir repuestos o piezas faltantes, visítenos en:

NAMESAKEHOME.COM/PARTS

o puede contactarnos por correo en:

8500 REX RD. PICO RIVERA, CA 90660



GARANTÍA LIMITADA DE UN AÑO

Para su tranquilidad, este producto Namesake está cubierto por una garantía de un año a partir de la fecha de compra. Para conocer más detalles sobre nuestra política de garantía, visite:

NAMESAKEHOME.COM/WARRANTY



CUIDADO Y LIMPIEZA

Para limpiar piezas de madera o metal, use un paño suave sin pelusa con un limpiador no tóxico. Seque con un paño inmediatamente. Para evitar rayar o dañar la superficie, no use agentes químicos ni materiales abrasivos. En cuanto a las telas, recomendamos usar una espuma limpiadora no tóxica para telas o un limpiador para cuero según corresponda. Hay kits para retocar disponibles para la venta contactándonos en:

(323) 909-5019 o NAMESAKEHOME.COM/PARTS



ALMACENAMIENTO

Dado que los materiales responden a la temperatura y la humedad, es importante guardar muebles en ambientes controlados. No deben ponerse los muebles a la luz solar directa ni cerca de salidas de aire acondicionado, radiadores, calefactores ni humidificadores. Cualquier cambio como los extremos de calor o frío, humedad o sequedad, pueden causar notoriamente encogimiento o hinchazón en la madera. La luz solar directa puede afectar la coloración de los materiales con el paso del tiempo.

ENREGISTREMENT

L'enregistrement du produit est simple à réaliser.
[NAMESAKEHOME.COM/REGISTRATIONS](https://namesakehome.com/registrations)



PIÈCES DE RECHANGE

Pour commander des pièces de rechange ou manquantes, veuillez visiter:
[NAMESAKEHOME.COM/PARTS](https://namesakehome.com/parts)
ou communiquer avec nous par courriel à l'adresse:
8500 REX RD. PICO RIVERA, CA 90660



GARANTIE LIMITÉE D'UN AN

Ne vous inquiétez pas, votre produit Namesake est couvert par une garantie d'un an à compter de la date d'achat. Pour plus de détails sur la politique de garantie, veuillez visiter:

[NAMESAKEHOME.COM/WARRANTY](https://namesakehome.com/warranty)



NETTOYAGE ET ENTRETIEN

Pour nettoyer le bois ou les pièces métalliques, utilisez un chiffon doux sans peluche et un produit nettoyant non toxique. Essayez immédiatement. Pour éviter les égratignures ou autres dommages, veillez à ne pas utiliser des produits chimiques ou des matériaux abrasifs. Pour les tissus, il est recommandé d'utiliser un produit nettoyant pour tissus non toxique ou pour cuir le cas échéant. Il est possible de se procurer des nécessaires de retouches en nous contactant à:

(323) 909-5019 ou [NAMESAKEHOME.COM/PARTS](https://namesakehome.com/parts)



ENTREPOSAGE

Compte tenu que les matériaux réagissent à la température et à l'humidité, il importe de ranger le mobilier dans des environnements contrôlés. Le mobilier ne doit pas être placé en plein soleil ni près des sorties d'air climatisé, des radiateurs, des appareils de chauffage ou des humidificateurs. Tout changement comme un froid ou une chaleur extrême, de l'humidité ou de la sécheresse pourrait causer la contraction ou le gonflement du bois.

La lumière directe du soleil peut altérer la couleur des matériaux au fil du temps.

TWIN/FULL BED
GUARDRAIL

CAMA INDIVIDUAL/
MATRINA BARRADERA

LIT SIMPLE/DOUBLE
BARRIÈRE DE SÉCURITÉ

M7159

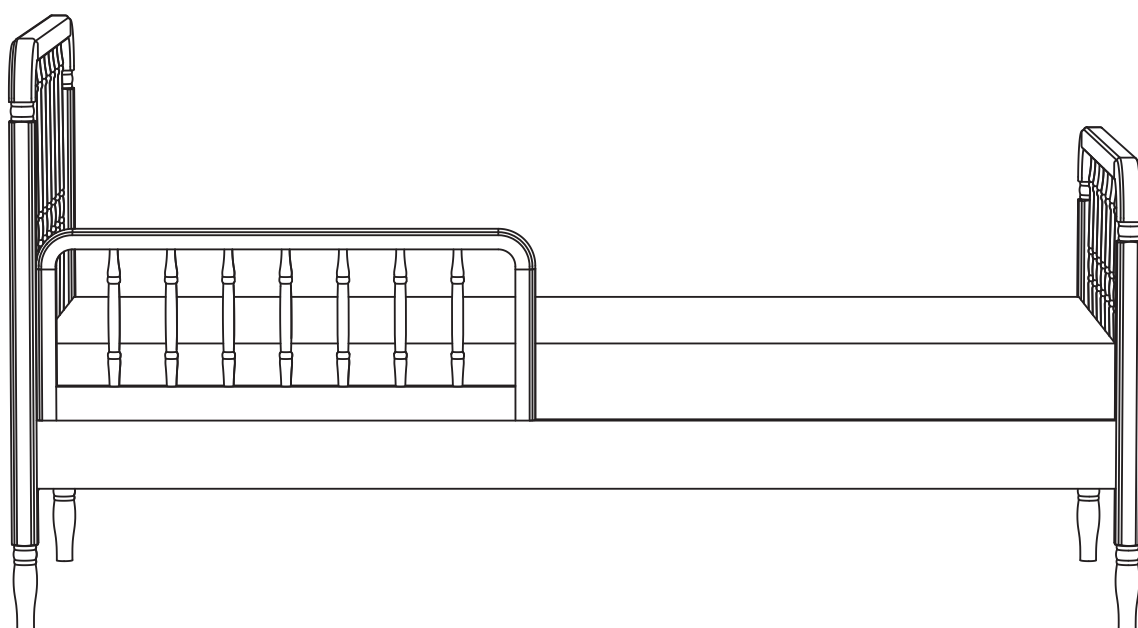

Not included, sold separately.
Please contact your retailer or purchase at:



No se incluye, se vende por separado.
Póngase en contacto con una tienda o haga su compra en:



Non inclus, vendu séparément.
veuillez contacter votre revendeur ou acheter sur :

[NAMESAKEHOME.COM/SUPPORT](https://www.namesakehome.com/support)

1

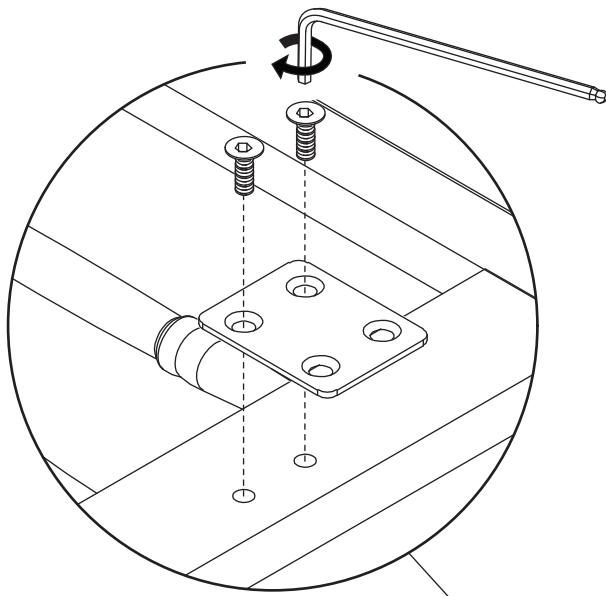

Do not tighten the bolt before
attaching to the bed.

No apriete el perno antes de
fijarlo a la cama.

Ne serrez pas le boulon avant
de le fixer au lit.

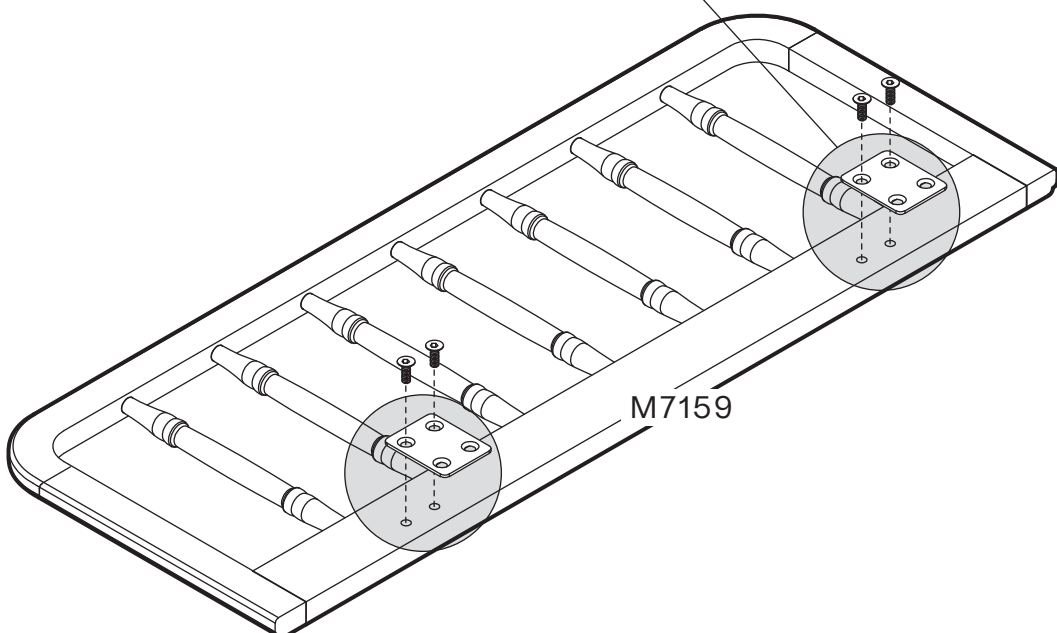

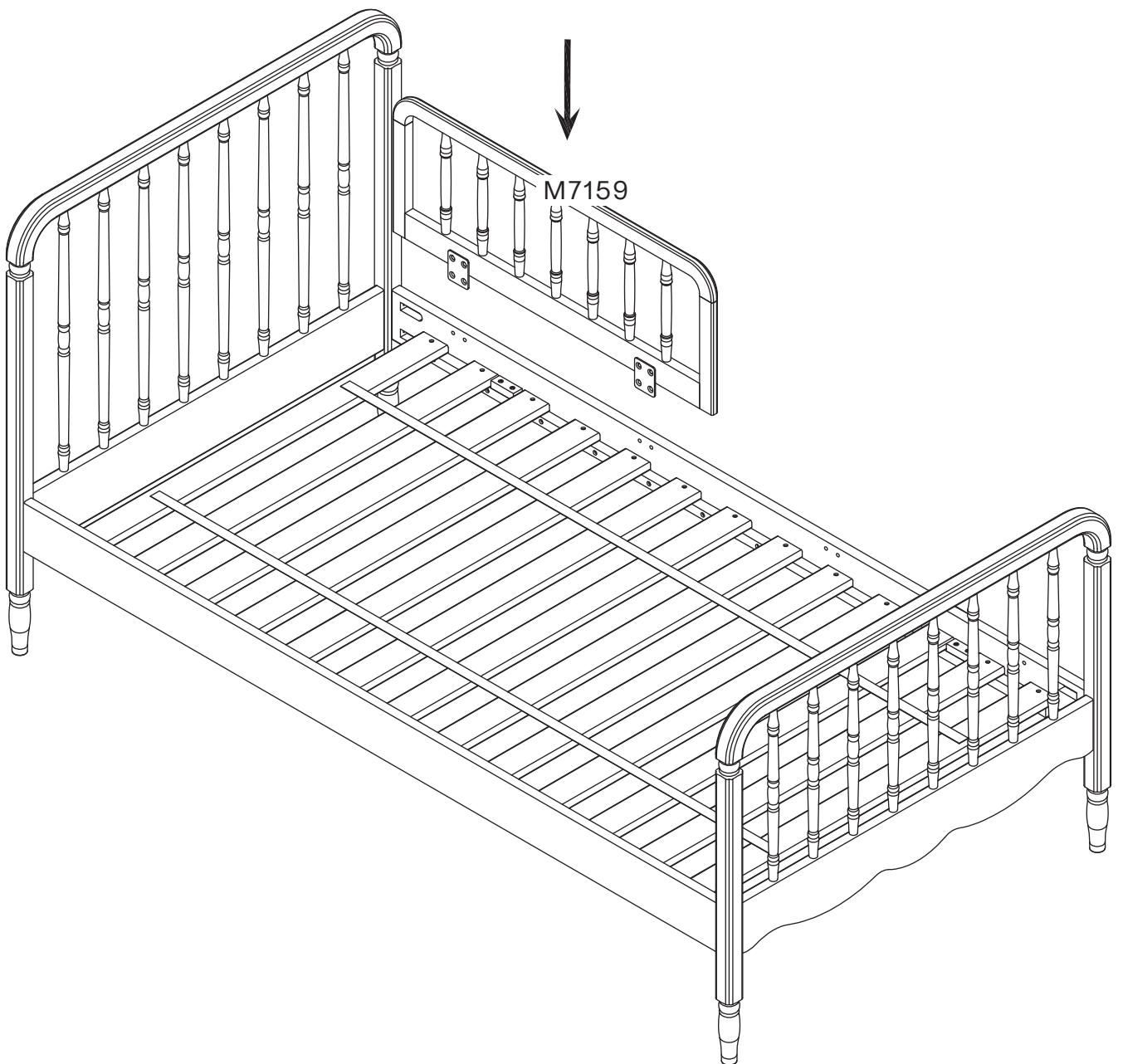

3

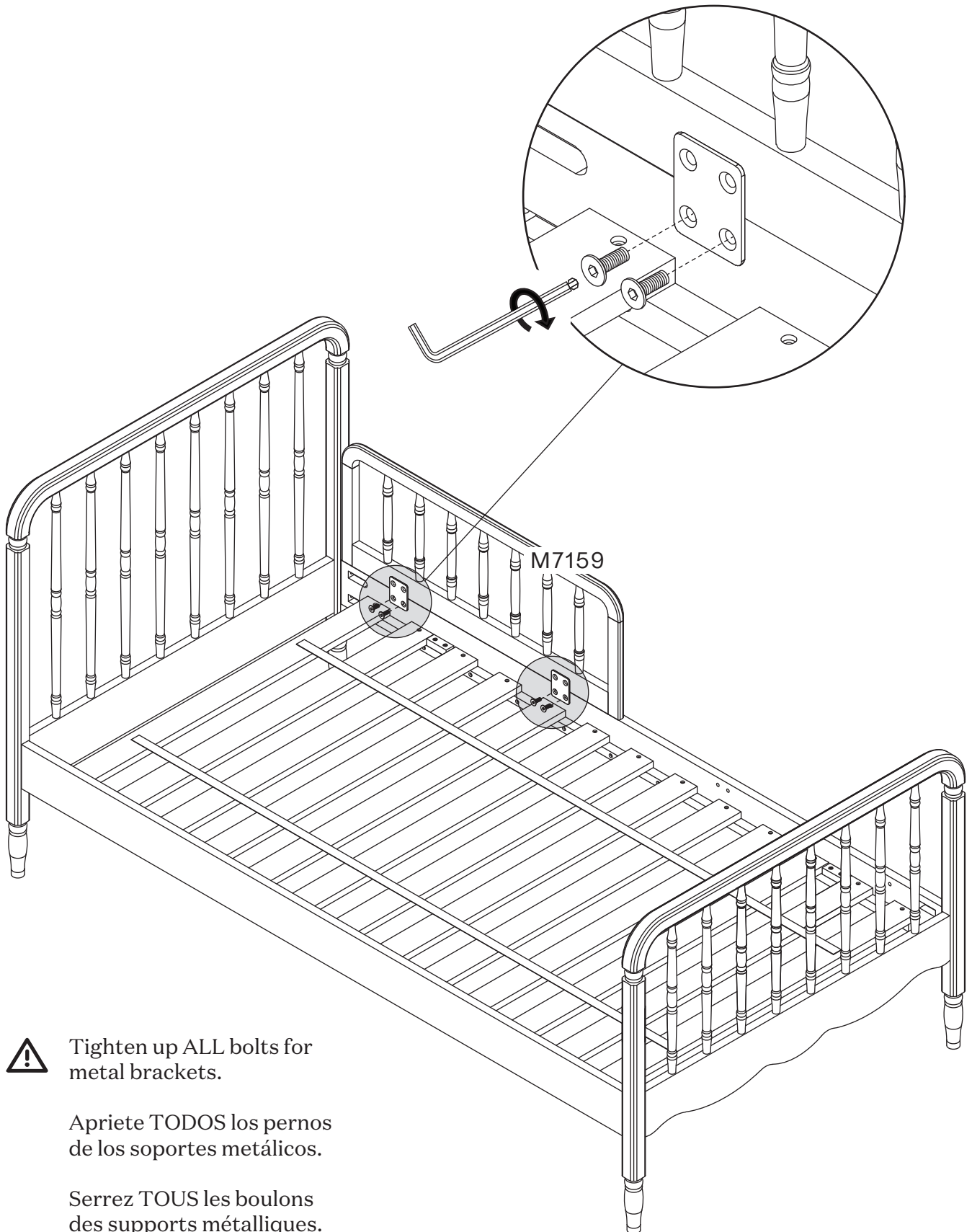

WELCOME HOME



¡LE DAMOS LA BIENVENIDA A CASA!



BIENVENUE À LA MAISON

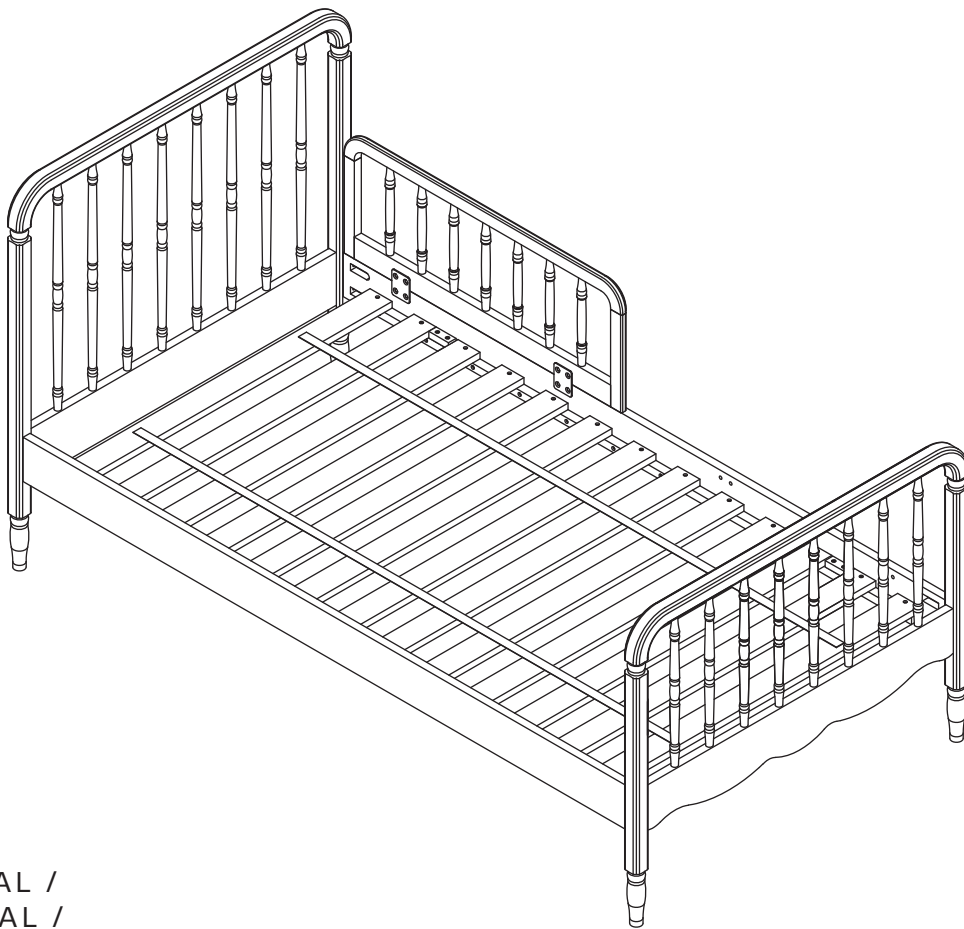

OPTIONAL /
OPCIONAL /
EN OPTION :

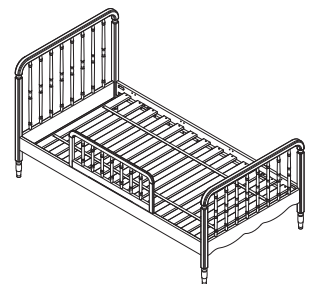
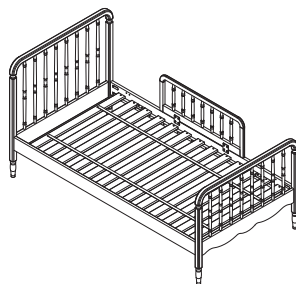
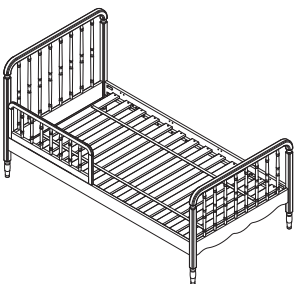



REVISED 20 APR 2026