

See-through Conversion Kit Installation (GSS50/62/74STC)

⚠ WARNING

- Allow the appliance to cool completely before performing any maintenance as it will remain hot after it is no longer operating.
- To avoid danger of suffocation, keep the packaging bag away from babies and children. Do not use in cribs, beds, carriages, or play pens. This bag is not a toy. Knot before throwing away.

Included in this kit:

Description	GSS50		GSS62		GSS74	
	Part #	Qty.	Part #	Qty.	Part #	Qty.
Top Frame	W280-10000635	1	W280-10000579	1	W280-10001843	1
Bottom Frame	W280-10000670	1	W280-10000546	1	W280-10001840	1
Top Trim	W715-10000633	1	W715-10004241	1	W715-10002678	1
Tempered Glass	W300-10001579	1	W300-10001580	1	W300-10001581	1
Glass Bracket	W080-10003359	2	W080-10003359	2	W080-10003359	2
Side Emitting LED	W405-10003358	1	W405-10003413	1	W405-10003423	1
Bottom Trim Bracket	W080-10000688	1	W080-10000563	1	W080-10001847	1
Standoff Bracket	W080-10003935	2	W080-10003935	2	W080-10003935	2
Side Trim	W715-10002508	2	W715-10002508	2	W715-10002508	2
Screw - #8x1/2 Hex Head Tek Stainless	N570-0008	28	N570-0008	30	N570-0008	32
Screw - Square Drive Stainless	W570-10001298	18	W570-10001298	20	W570-10001298	22

note:

Remove all protective wrap from the stainless steel parts.

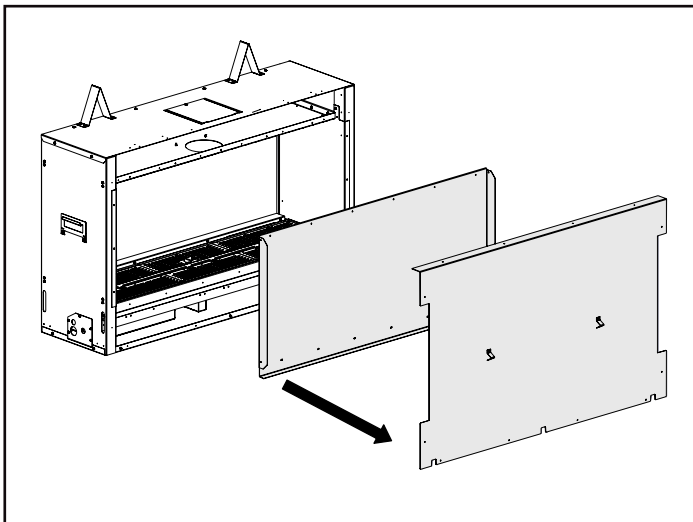

1. Uninstall the screws to remove the back panel, and the back of the firebox.

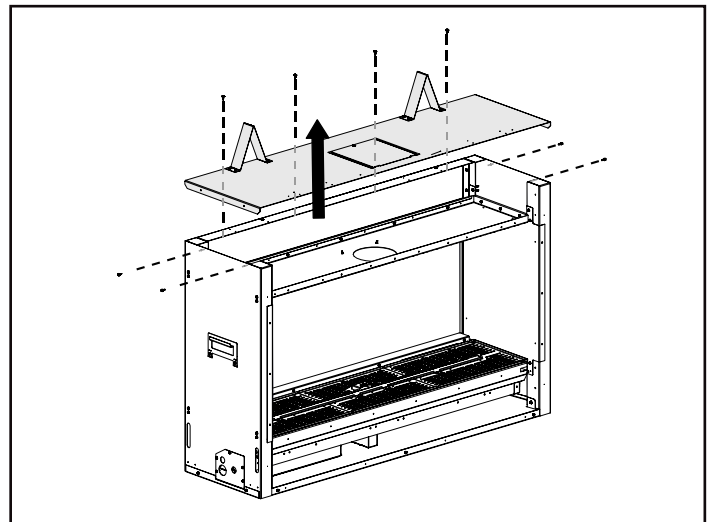

2. Uninstall the screws to remove the outer shell top.

Quality System Certified To

ISO
9001:2015

W415-10004755 / A-0 / 11.08.24

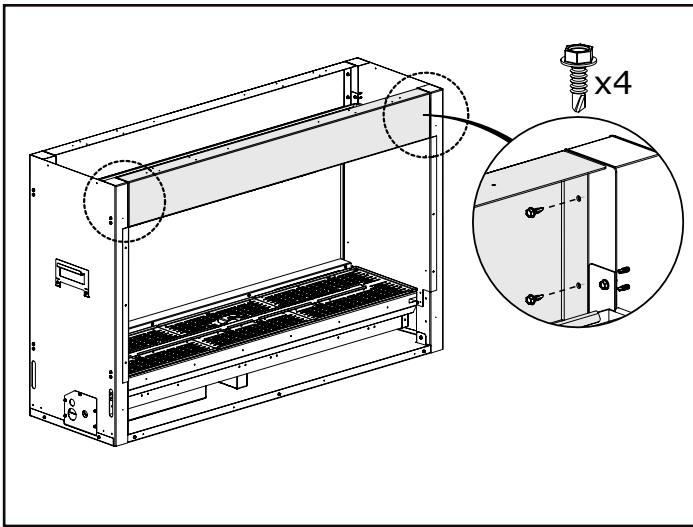

3. Install the top frame with the 4 screws provided with this kit on the inside facing flanges.

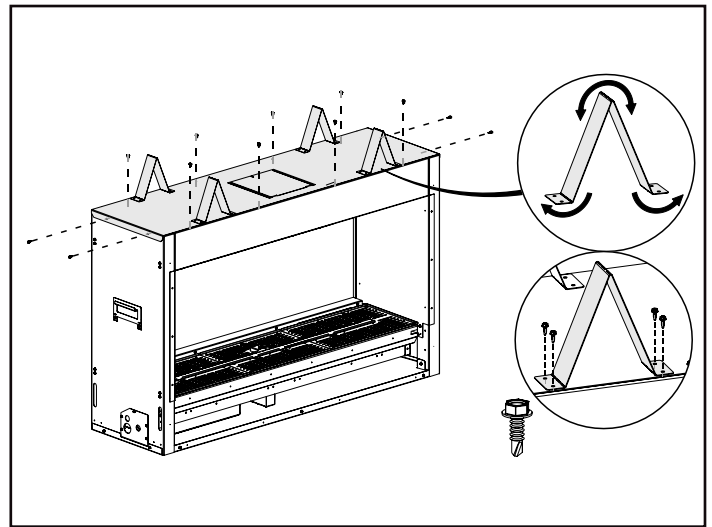

4. Install the outer shell top with the screws previously removed and bend and secure the 2 standoffs with 8 screws provided.

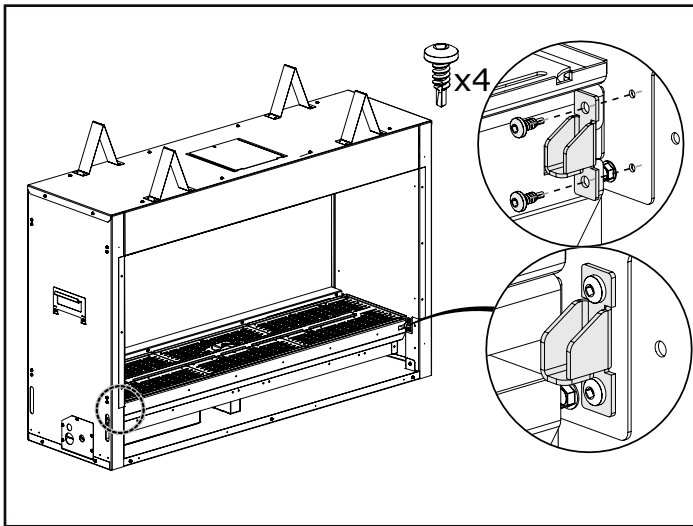

5. Install 2 glass brackets on both sides of the firebox with the screws provided. Do not install the glass until conversion is complete.

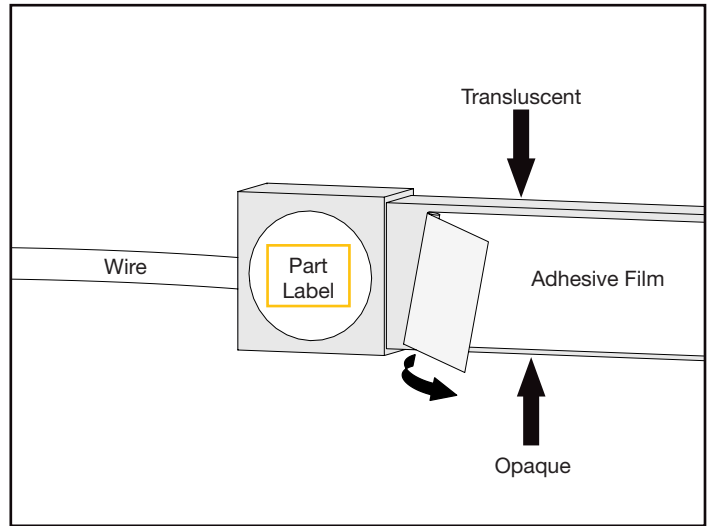

6. Orientation critical! Peel the film from the LED strip on the side with the label. This will ensure that the translucent portion containing the lights is facing upwards. **Note:** There is film on both sides on the LED strip.

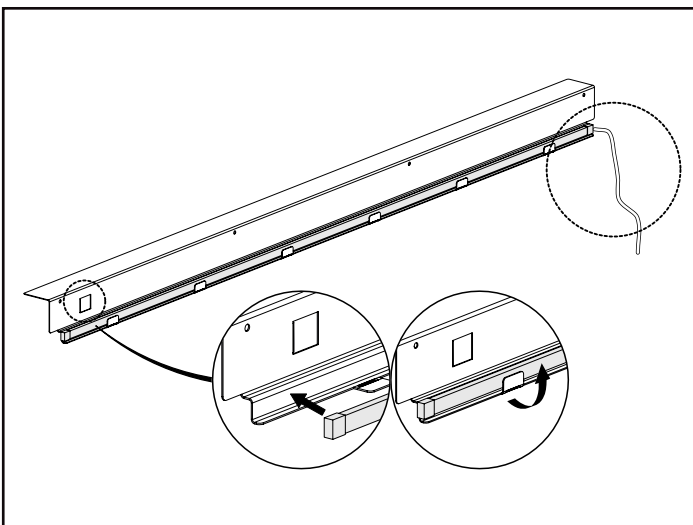

7. Apply the LED strip to the outward facing flange of the bottom trim, orientation of the wire is critical. Bend the securing tabs in place.

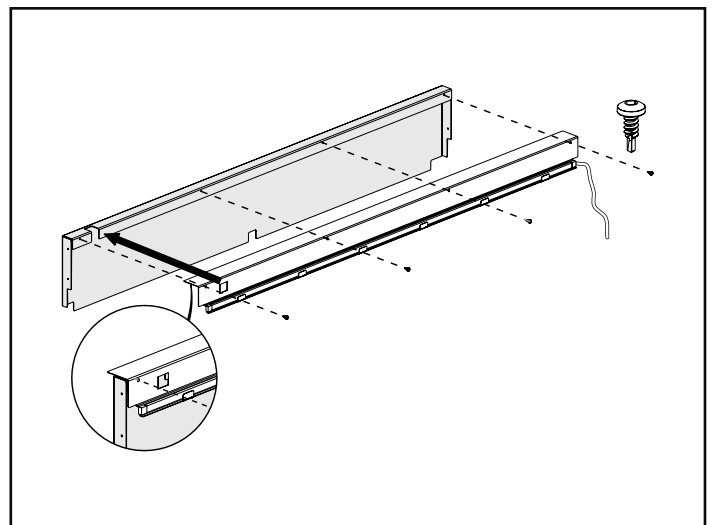

8. Secure the bottom trim to the inside of the bottom frame with the screws provided in this kit.

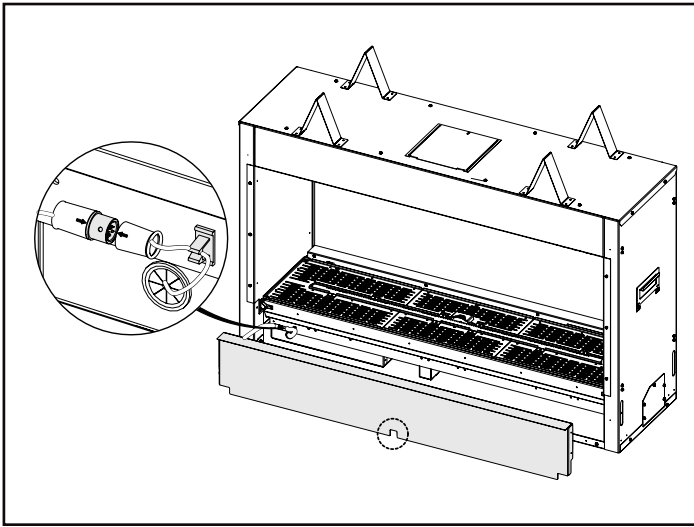

9. Insert the wire that connects to the LED strip into the clip. Align the arrows and connect the wire.

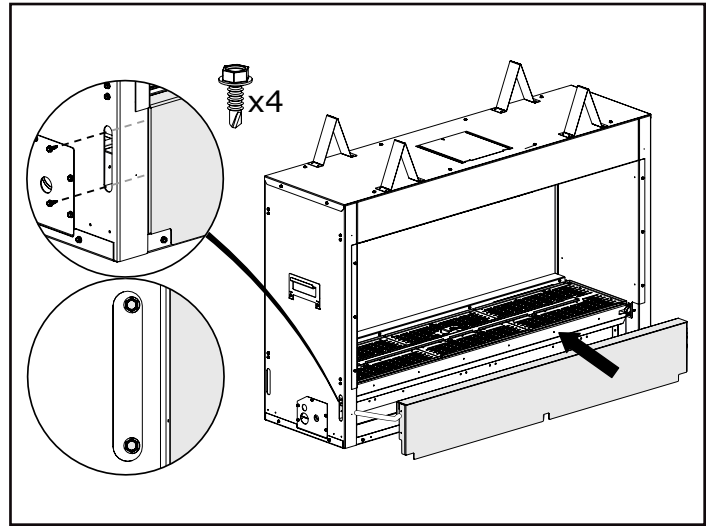

10. Install the bottom frame with the notches facing down.

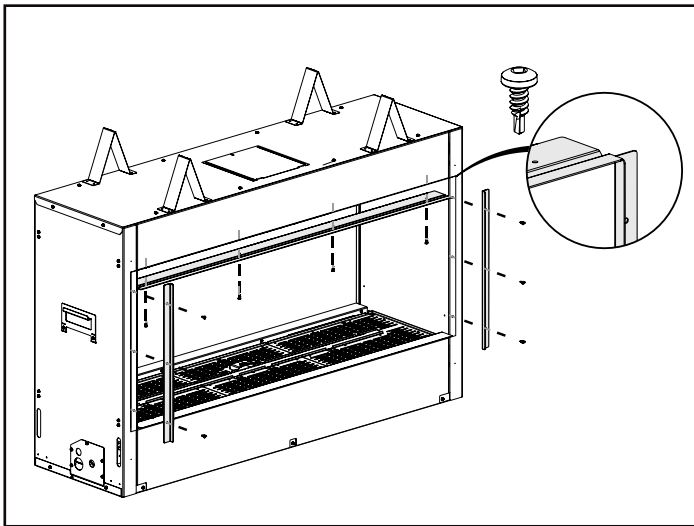

11. Secure the top trim and the 2 side trims with the screws provided.

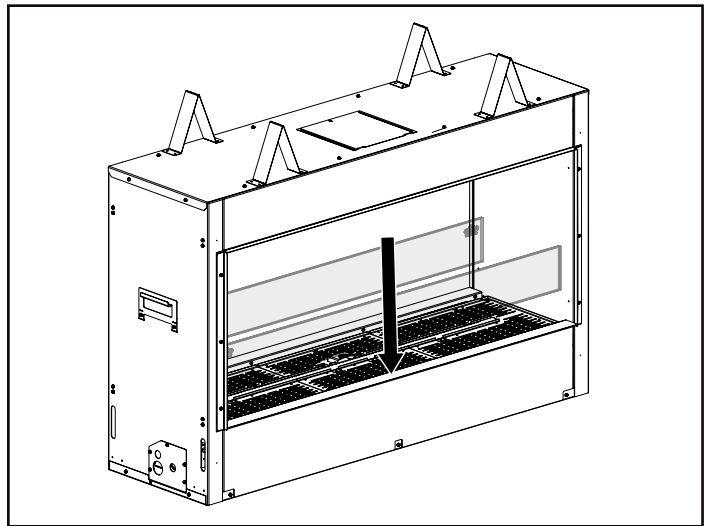

12. Install glass.

Kit de conversion pour foyer double face - Installation (GSS50/62/74STC)

! AVERTISSEMENT

- Laissez l'appareil refroidir complètement avant d'effectuer toute opération d'entretien, car il restera chaud après avoir cessé de fonctionner.
- Afin d'éviter les risques de suffocation, gardez le sac d'emballage loin des bébés et des jeunes enfants. Ne le laissez pas traîner dans les berceaux, les lits, les poussettes ou les parcs de jeu. Ce sac n'est pas un jouet. Nouez-le avant de le jeter.

Inclus dans ce kit:	GSS50		GSS62		GSS74	
Description	Pièce n°	Qty.	Pièce n°	Qty.	Pièce n°	Qty.
Cadre supérieur	W280-10000635	1	W280-10000579	1	W280-10001843	1
Cadre inférieur	W280-10000670	1	W280-10000546	1	W280-10001840	1
Garniture supérieure	W715-10000633	1	W715-10004241	1	W715-10002678	1
Verre trempé	W300-10001579	1	W300-10001580	1	W300-10001581	1
Support de verre	W080-10003359	2	W080-10003359	2	W080-10003359	2
DEL émettant sur les côtés	W405-10003358	1	W405-10003413	1	W405-10003423	1
Support de garniture inférieure	W080-10000688	1	W080-10000563	1	W080-10001847	1
Support d'entretoise	W080-10003935	2	W080-10003935	2	W080-10003935	2
Garniture latérale	W715-10002508	2	W715-10002508	2	W715-10002508	2
Vis - #8x1/2 tête hexagonale Tek en acier inoxydable	N570-0008	28	N570-0008	30	N570-0008	32
Vis - À empreinte carrée en acier inoxydable	W570-10001298	18	W570-10001298	20	W570-10001298	22

note:

Retirez toute la protection des pièces en acier inoxydable.

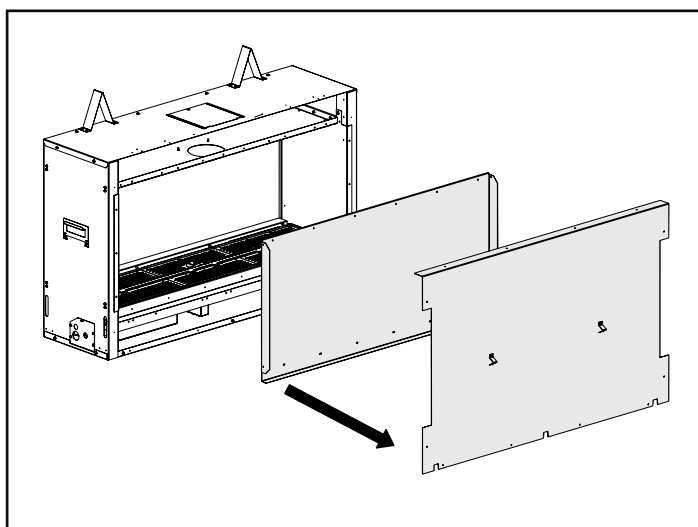

1. Dévissez les vis pour retirer le panneau arrière et l'arrière de la chambre de combustion.

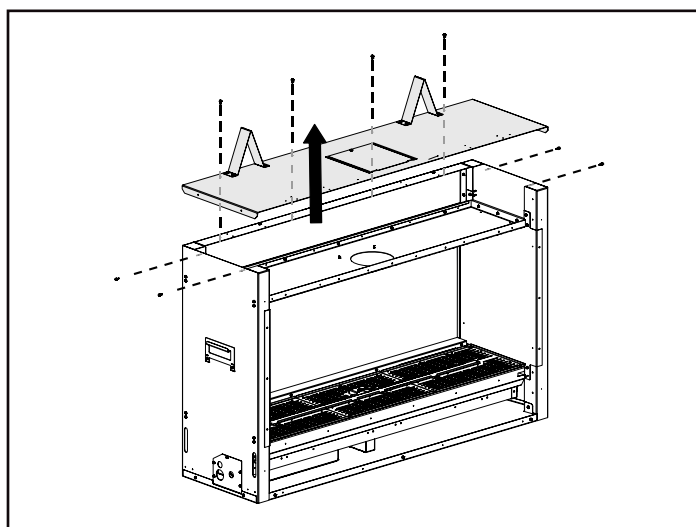

2. Dévissez les vis pour retirer le capot supérieur de l'enveloppe extérieure.

Système de qualité certifié

ISO
9001:2015

W415-10004755 / A-0 / 11.08.24

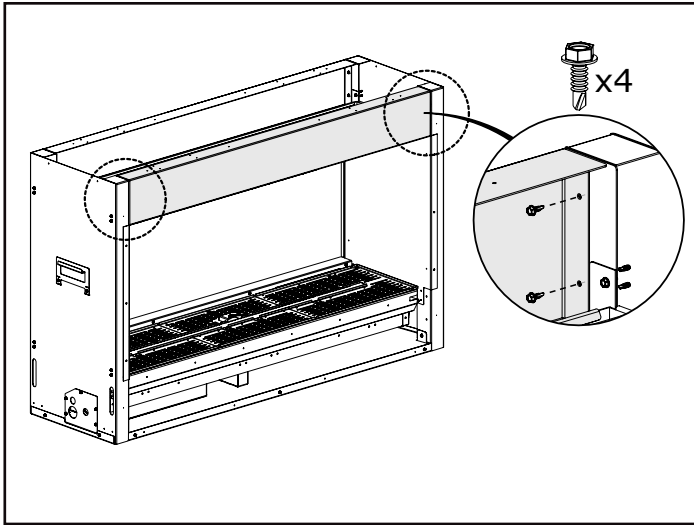

3. Installez le cadre supérieur avec les 4 vis fournies dans ce kit sur les brides intérieures.

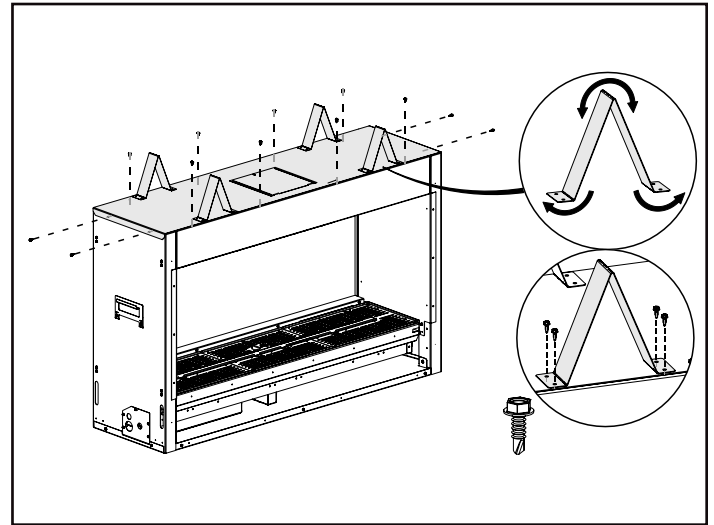

4. Installez le haut de la coque extérieure avec les vis précédemment retirées et pliez et fixez les 2 entretoises avec les 8 vis fournies.

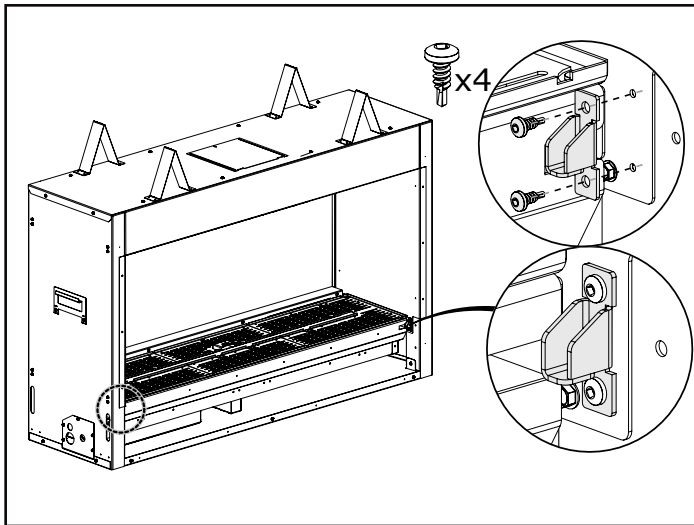

5. Installez 2 supports de verre de chaque côté de la chambre de combustion avec les vis fournies. Ne fixez pas le verre avant que la conversion ne soit terminée.

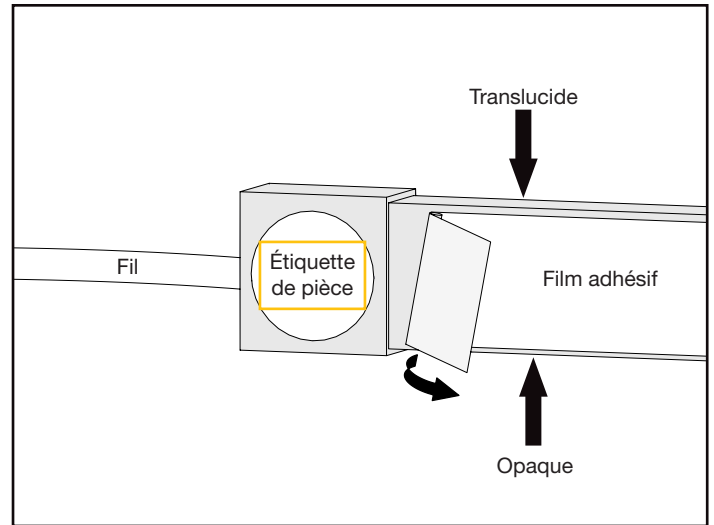

6. Orientation essentielle ! Retirez le film de la bande DEL du côté avec l'étiquette. Cela garantira que la partie translucide contenant les lumières est orientée vers le haut. **Note :** Il y a un film des deux côtés de la bande DEL.

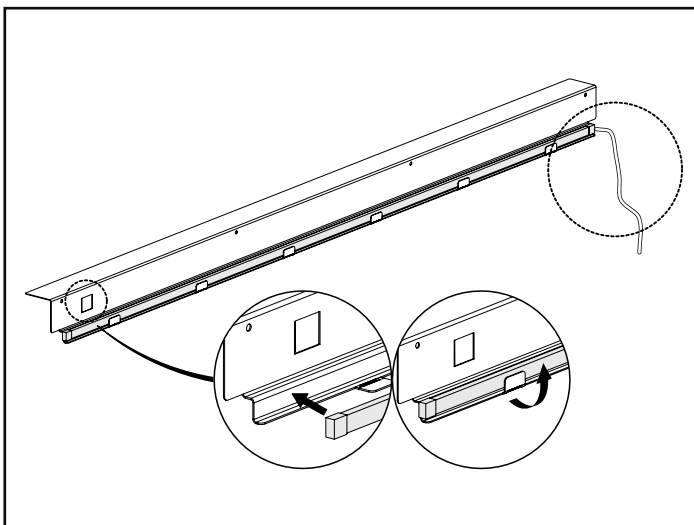

7. Appliquez la bande DEL sur la bride orientée vers l'extérieur de la garniture inférieure, l'orientation du fil est essentielle. Pliez les languettes de fixation en place.

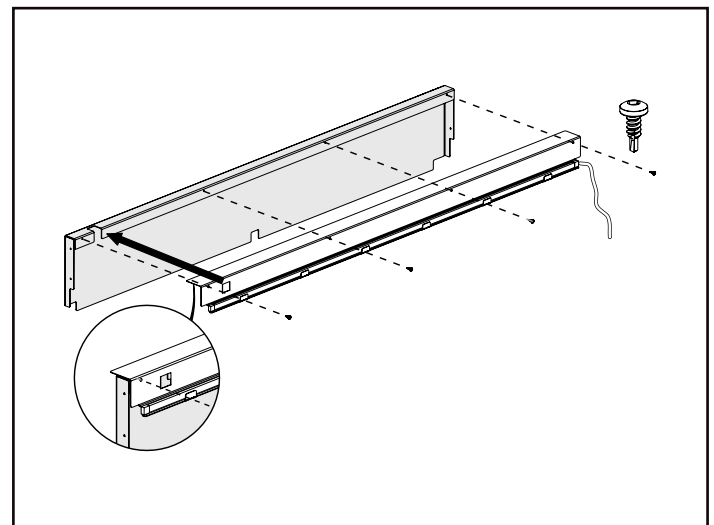

8. Fixez la garniture inférieure à l'intérieur du cadre inférieur avec les vis fournies dans ce kit.

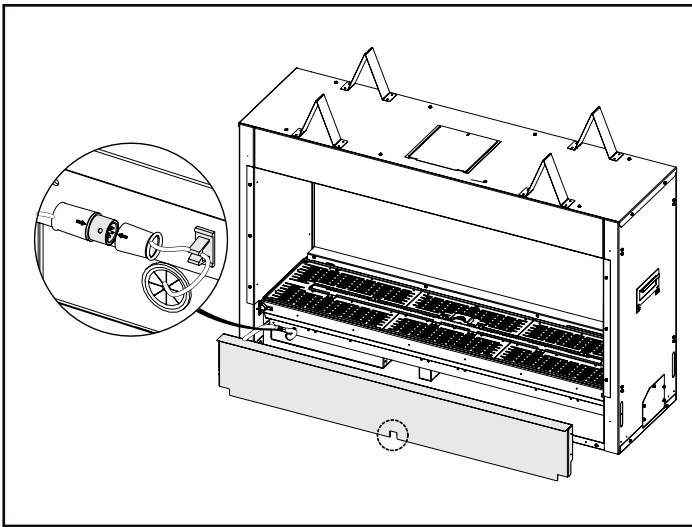

9. Insérez le fil qui se connecte à la bande LED dans le clip. Alignez les flèches et connectez le fil.

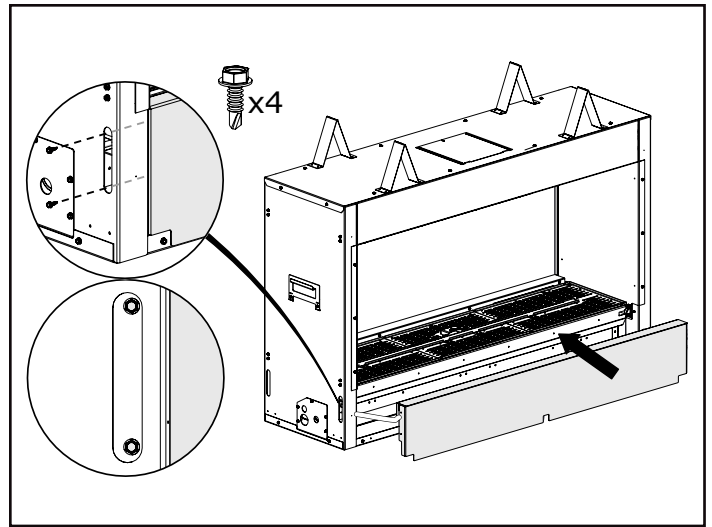

10. Installez le cadre inférieur avec les encoches orientées vers le bas.

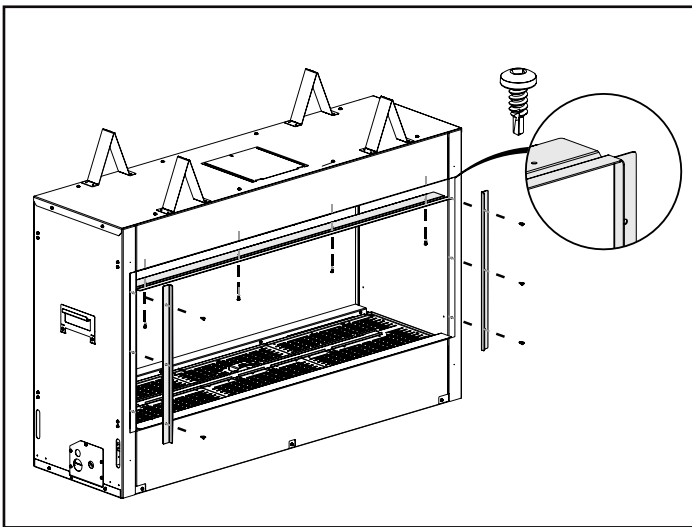

11. Fixez la garniture supérieure et les 2 garnitures latérales avec les vis fournies.

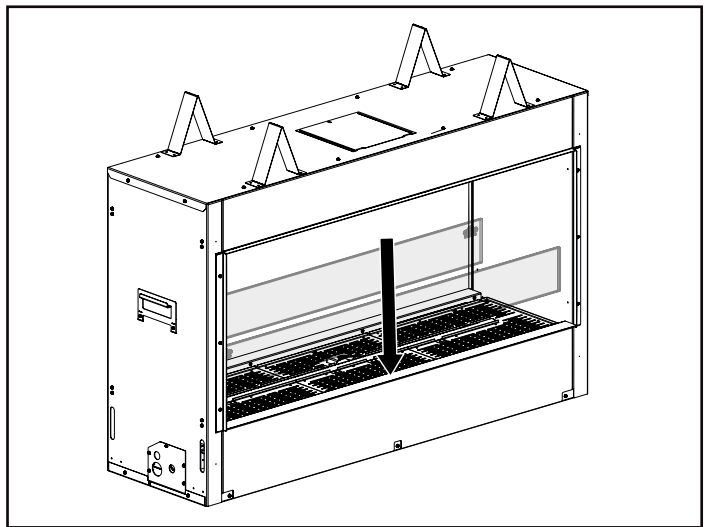

12. Installez le verre.