

HEKMAN®

A HOWARD MILLER COMPANY
Grand Rapids, Michigan

INSTALLATION INSTRUCTIONS

Pattern Description 25624 side chair

DO NOT SCALE SKETCHES







COPYRIGHT 1997 HEKMAN FURNITURE COMPANY

Pattern Number(s)

25624

Drawn By AMY

Date 9/12/21

PARTS			Q' TY
A		5/16*2"	4
B		5/16 "	8
C		5/16 "	8
D		5/16 "	4
E		13MM	1
F		5/16 "	1

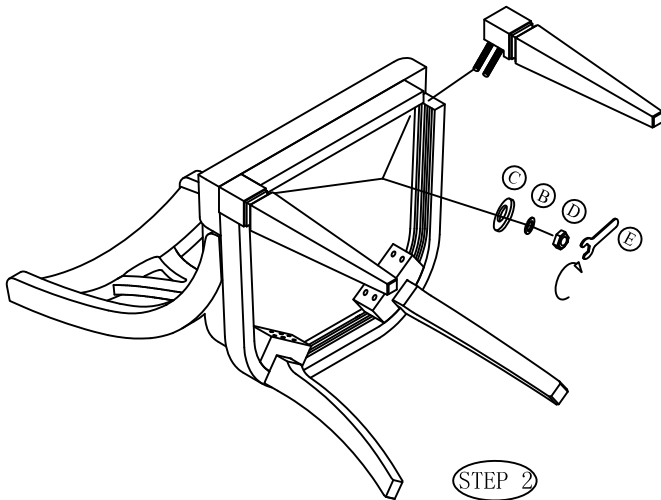
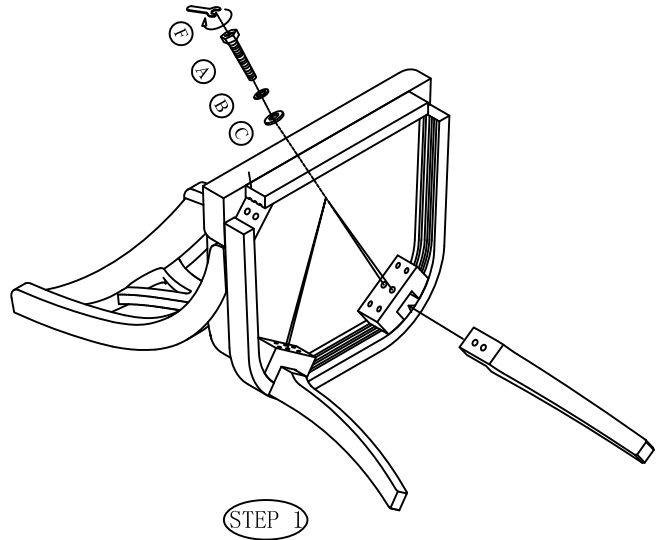

TO ASSEMBLE: (Two people required)

Step 1: Place the Chair Back on a soft clean surface, and assemble Attach both back legs to the seat frame (Step1), using four bolts (A) with four lock washers (B) and four flat washers (C) tighten with the Spanner wrench(F). Do not fully tighten any bolts until chair has been completely assembled.

Step 2: Attach both front legs to the seat frame using four nuts (D), and four lock washers (B) and four flat washer (C) Tighten with the wrench(E). Do not tighten the four nuts completely at this time.

Step 3: Set the chair on a flat surface to ensure all four legs touch the floor, then tighten all bolts and nuts.

