

Product Specifications

5.25-Gallon Round Screw-Top Pail, Closed Handle Version

Note: *Rated for Solids Y24/S for Packaging Group II and III (USA and Canada)

Multiple Uses

Dry Products

UN Solids rated to Y24/S

Product Codes

Container:

Description: 5.25Gallon 90 MIL Quarter Turn Screw-Top Pail

Features

Gauge: 90 mil.

Nominal capacity: 5.25 USG / 19.87L

Stack performance: 350lbs.*

Tare weights: Body: 2.01 lbs. / .91 kgs.

Note: *Ratings will be reduced with uneven load distribution.

Specifications with Cover

Dimensions: 12-5/16" DIA. X 14-5/8" H

Maximum capacity: 5.12 USG / 19.57 L

Tare weight: 2.67 lbs. / 1.21 kgs.

Colors

Standard: White, Black, Natural

Custom: Available at manufacturer's discretion

Decorating Options*

Note: *See Decoration Summary for further details.

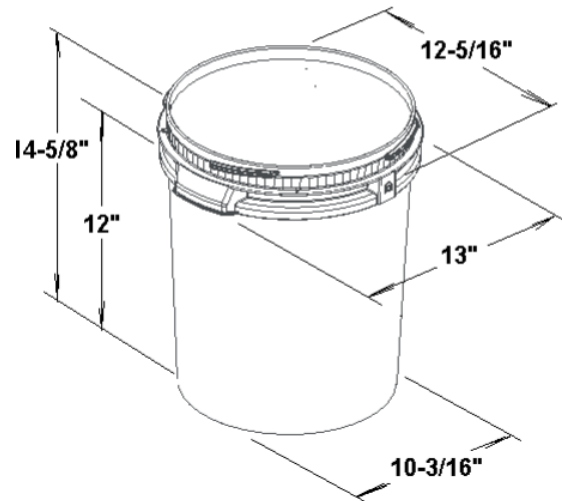

Shipping Data

Qty. per pallet:	168
Gross Weight (lbs./kgs.):*	337.65/152.88
Den. (lbs./C.F./kgs./m3):	6.42/102.48
Length (in./cm.):	49.88/126.7
Width (in./cm.):	37.56/95.6
Height (in./cm.):	48.49/123.16

Estimated truckload quantity of 6,720 bodies and covers**

Bodies

Filled Containers

36 (12 per layer / 3 layers high)
Pallet height: 48.12 "

Notes: *Weight does not include pallet / packaging
**Truckload quantity based on 53' trailer

Materials

FDA and HPB approved materials Resin:
Body: High Density Polyethylene (HDPE)

MSDS Sheets available upon request

Optional Carrying Handle

Plastic

DISCLAIMER
THIS INFORMATION IS PROVIDED AS A GENERAL GUIDE, INCLUDING DIMENSIONS. IT IS THE CUSTOMER'S RESPONSIBILITIES TO SELECT THE PROPER CONTAINER FOR PRODUCT AND APPLICATION COMPATIBILITY.

DISTRIBUTED BY:



REF NO.:

DWG31019

DESCRIPTION:

5.25 Gallon White HDPE Screw Top Pail