



## INFRARED SAUNA USER GUIDE

MODELS  
**SC-SS0023-2P**



# DON'T WAIT! REGISTER NOW!

Register your product within 90 days to ensure your sauna is recognized as an official purchase and is eligible for warranty coverage.

register online at [www.saunaspa.com/register](http://www.saunaspa.com/register) or scan the QR code at Page 2.

# PRODUCT REGISTRATION\*


**IMPORTANT:** Warranty will not be recognized unless product is registered.

**Register online at [www.saunaspa.com/register](http://www.saunaspa.com/register)** . or Scan the QR code below.

Registering online is fast, secure, and ensures we receive your information.

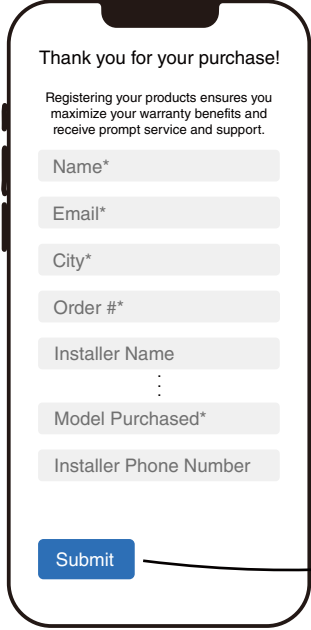
**1**

USE YOUR PHONE CAMERA  
TO SCAN THE QR CODE



**2**

FILL IN A QUICK  
REGISTRATION FORM



The image shows a smartphone screen with a registration form. At the top, it says 'Thank you for your purchase!' followed by a message: 'Registering your products ensures you maximize your warranty benefits and receive prompt service and support.' Below this are several input fields: 'Name\*', 'Email\*', 'City\*', 'Order #\*', 'Installer Name', 'Model Purchased\*', and 'Installer Phone Number'. A blue 'Submit' button is at the bottom of the form. An arrow points from this button to a larger 'Submit' button shown in a dashed oval on the right side of the diagram.

**3**

CLICK SUBMIT AND  
ENJOY PEACE OF MIND

# IMPORTANT WARRANTY INFORMATION!

## WARRANTY AND REPAIR GUIDELINES

SaunaSpa warrants that this sauna unit will be free from manufacturer defects and malfunctions. For terms and conditions please refer to latest SaunaSpa Warranty at [www.saunaspa.com/register](http://www.saunaspa.com/register).

**Please be advised failure to comply with any of the following will VOID the warranty.**

1. Sauna must registered within 90 days of delivery. See [www.saunaspa.com/register](http://www.saunaspa.com/register).

### **Warranty Period:**

This product is covered under warranty for a period of one year for electrical parts, five years for wood parts, commencing from the date of purchase.

For further information or assistance, visit [www.saunaspa.com/warranty](http://www.saunaspa.com/warranty) or call 866-733-4043.

# TABLE OF CONTENTS

USER INSTRUCTIONS .....	5
WARNING .....	5
ASSEMBLY TIPS.....	7
SPECIFICATONS .....	8
PRODUCT SIZE CHART.....	8
COMPONENTS.....	9
INSTALLATION .....	10
INSTRUCTIONS FOR USE.....	15
SUGGESTIONS .....	17
TROUBLE SHOOTING .....	18

INSTALLATION & USER GUIDE

## IMPORTANT!

- Malfunctions, damages, part replacements and labor resulting from improper installation, negligence, or lack of care and maintenance will NOT be covered under the SaunaSpa Warranty.
- PRIOR TO INSTALLATION, ENSURE THAT THE PRODUCT IS POWERED OFF.

Thank You for choosing SaunaSpa for health, beauty and relaxation. Now you can enjoy your own private sanctuary in the comfort of your own home.

## USER INSTRUCTIONS

1. Check for visible damages upon delivery of sauna. Any damages to packaging should be reported immediately to shipping company delivery representative and SaunaSpa's Customer Service Dept.
2. Check model and accessories are correct, including voltage input. Any discrepancies are to be reported to SaunaSpa's Customer Service Dept. within 48 hours of delivery.
3. Read installation instructions in detail for a secure and effective installation of SaunaSpa sauna.
4. SaunaSpa shall not be responsible for product damage or malfunction caused by self-installation or installation procedures which do not comply with user manual.
5. SaunaSpa saunas are for indoor use only.

## WARNING

### Please read carefully before using sauna

- DO NOT use the sauna product with any of the following Health Conditions:

1. Any type of respiratory condition
2. Any type of a heart condition
3. High or low blood pressure
4. Pregnancy
5. Any skin disease or disorders
6. After or while drinking alcohol or alcoholic beverages
7. Hemophilia or are prone to bleeding

Check with your doctor regarding the use of this product if you have any other health conditions.

- Hyperthermia occurs when the internal temperature of the body reaches a level several degrees above the normal body temperature of 98.6°F ( 37°C ). The symptoms of hyperthermia include an increase in the internal temperature of the body, dizziness, lethargy, drowsiness, and fainting. The effects of hyperthermia include:
  - a. Failure to perceive heat
  - b. Failure to recognize the need to exit, or Physical inability to exit the room
  - c. Unawareness of impending hazard
  - d. Fetal damage in pregnant women
  - e. Unconsciousness

# WARNING

## Please read carefully before using sauna

### ● Installation & Environment:

1. Install the sauna on a level surface indoors or in a dry, covered area. Avoid placing it in damp or water-prone areas.
2. Water seepage over time is normal and typically dries quickly due to the heated environment.
3. Suitable foundations include concrete slabs, pavers, gravel, cinder blocks, or solid wood decking.

### ● Children & Supervision:

1. Children must use the sauna only under adult supervision and after consulting a doctor.
2. Never allow play in or around the sauna.

### ● Electrical Safety:

1. Keep all electrical components dry. Do not touch them with wet hands or use the sauna during storms.
2. Never expose the control system to water or disassemble it.
3. Repairs must be performed by authorized technicians only.
4. Ensure proper wiring and connections; consult a certified electrician if unsure.
5. Do not operate with a damaged power cord or plug.
6. Always allow 30 seconds between powering the control system on and off.

### ● Usage Warnings:

1. Do not pour water on the infrared heaters / radiators.
2. Do not insert objects (fingers, sticks, etc.) into any openings or heating elements.
3. Do not touch the heating element, control panel, or light bulb when hot.
4. Do not sleep inside the sauna while it's operating.
5. Never use the sauna under the influence of alcohol, drugs, or medication.
6. Pregnant or menstruating women should not use the sauna.
7. If you feel dizzy, weak, or unwell, stop use immediately.
8. Wait 10–20 minutes after intense exercise before using the sauna.

### ● Medical Conditions:

1. Consult your doctor before using the sauna if you have medical issues such as diabetes, high/low blood pressure, heart disease, or recent trauma.
2. Be aware of possible allergies to red cedar wood (MCS – Multiple Chemical Sensitivity).

### ● Usage Limits & Maintenance:

1. Operate for a maximum of 4 hours, then rest the sauna for at least 30 minutes.
2. Do not use or store flammable items near the sauna.
3. Keep vents unobstructed for airflow and ventilation.
4. Always clean sweat and debris from the floor and surfaces after each use.
5. Use only non-toxic, water-based cleaners.
6. Do not place or store items inside, on, or above the sauna.
7. Never tilt, strike, or install spray devices or shower heads in or above the sauna.

## WARNING

- General Safety:
  1. Be cautious when entering/exiting—mind your head.
  2. Keep the floor heater and seating area dry to avoid damage.
  3. Do not bring pets into the sauna.
  4. Covering the heater or infrared emitter is a fire hazard.
  5. If replacing the bulb, turn off power and let it cool first.

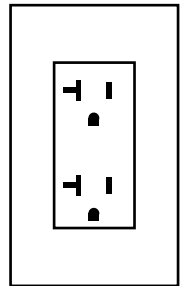
## ASSEMBLY TIPS

Before beginning assembly, carefully read all instructions and safety warnings.

- This sauna requires at least 3 adults for assembly.
- Unpack all components and verify you have all the listed parts.
- NOTICE: Some components may come pre-installed or partially assembled.
- Protect the sauna's wood surfaces during assembly to avoid scratches or damage.
- Retain this manual for future reference.

## ELECTRICAL REQUIREMENTS

- All electrical work must be performed by a licensed, qualified electrician.
- Ensure compliance with national, state, and local electrical codes — consult a licensed electrician.
- The electrician must supply all required wiring and connections.
- Sauna requires 120VAC, 25-amp dedicated circuit for use.
- Do not use wall adapters or extension cords.
- The heater must be hardwired by a licensed professional.
- Route the power cord to avoid foot traffic or any risk of it being pinched by objects.
- Ensure all cables and circuits have proper waterproof protection to prevent water ingress and short circuits.



## CHOOSING A LOCATION

- Place the sauna on a dry, solid, level surface that can support its weight. Avoid areas prone to dampness or water exposure.
- Maintain at least 6 inches of clearance between the sauna and any walls.
- Ensure the main power cord can reach an accessible outlet with ease.
- Position the sauna away from hazards like water sources, flammable objects, or combustible materials.

## RECOMMEND TOOLS



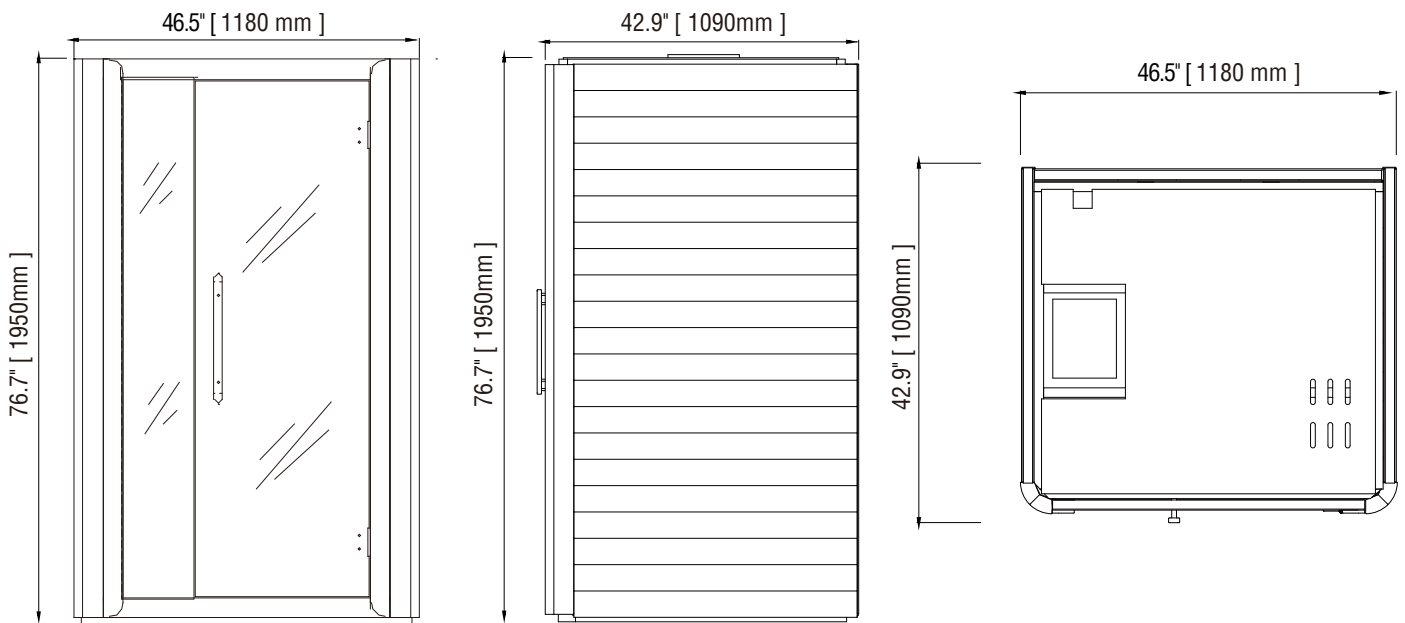
1. Pencil      2. Hammer      3. Tape Measure      4. Electric Drill      5. "+" screwdriver

# SPECIFICATIONS

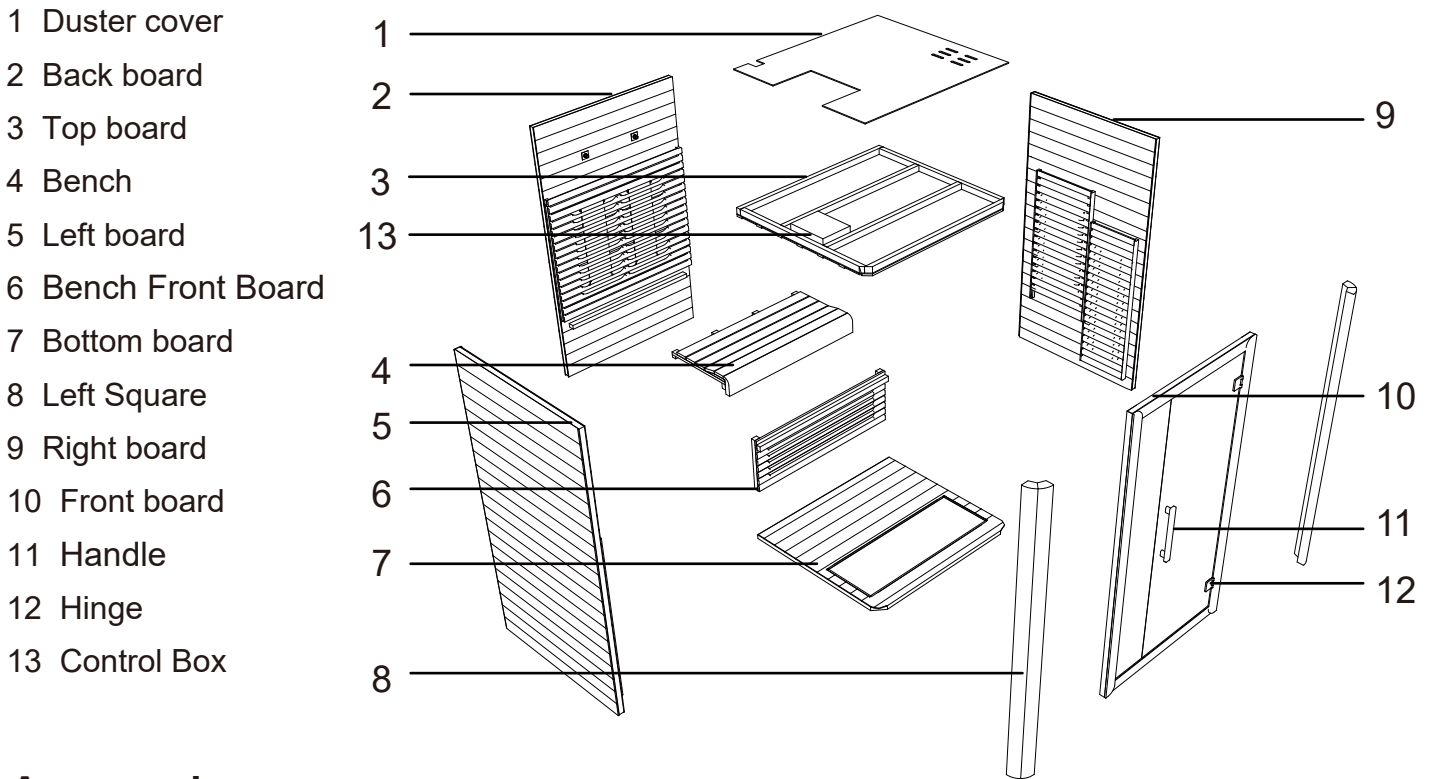
SPECS	SC-SS0023-2P
Assembled Tent Dimensions(L x W x H)	46.5"x 42.9" x 76.7" (1180*1090*1950mm)
Power Output	1960 Watts
Maximum Temperature	149°F ( 65°C )
Voltage	120V AC / 60Hz
Function	Control panel with temp adjust and timer, Audio with USB Disk/Bluetooth/FM,Color LED light, Oxygen ionizer

# PRODUCT SIZE CHART

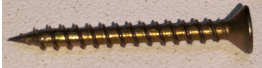








INSTALLATION & USER GUIDE



# COMPONENTS



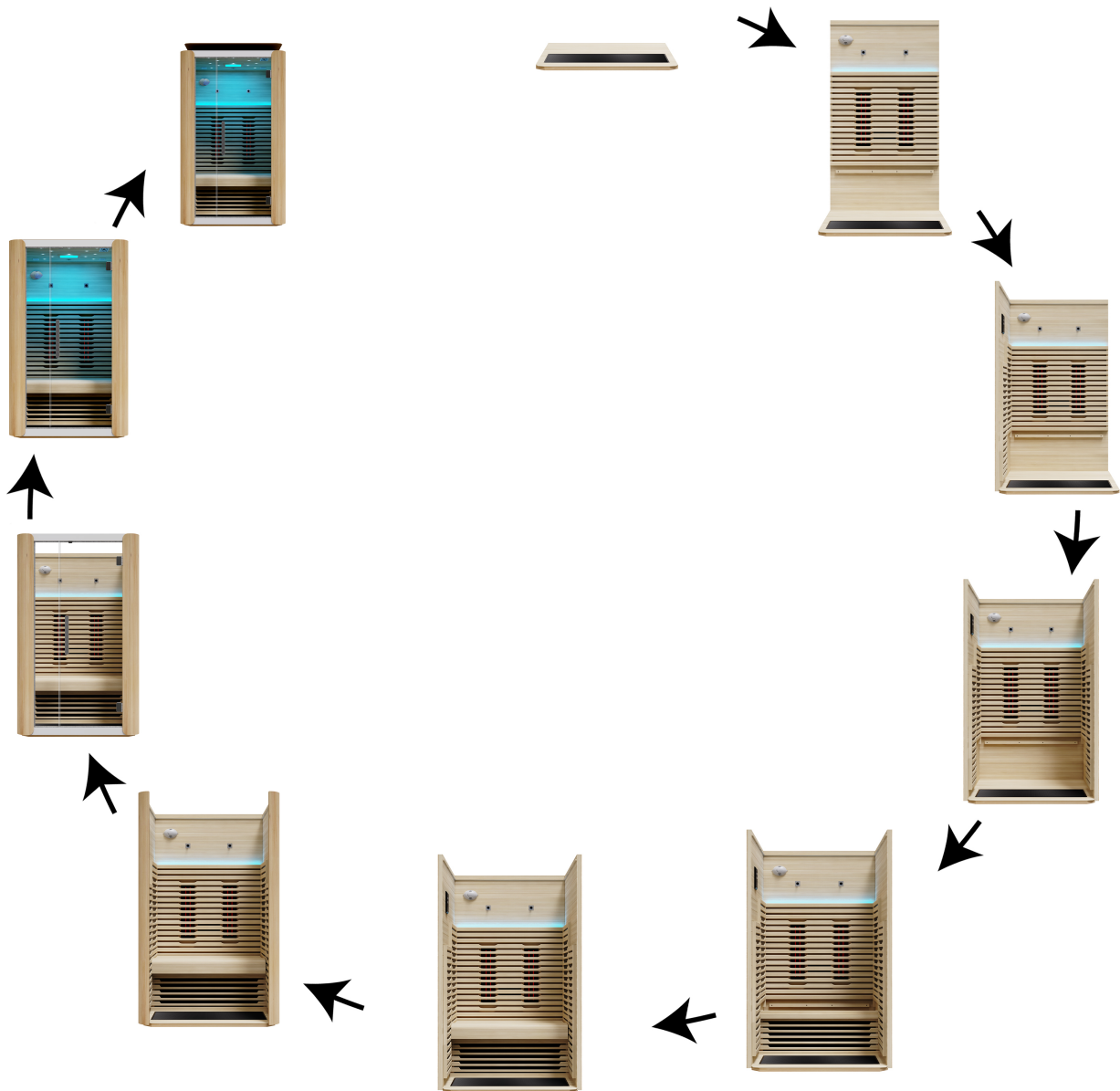
## Accessories

 Self-tapping Screw(3*25) x 6	 Self-tapping Screw(3*35) x 4	 Self-tapping Screw(5*50) x 4
 Newspaper and book rack x 1	 Handles with Screws x 1	 Oxygen ionizer
 Hexagen Wrench x 1	 Door handle installation kit x 1	 DC Adapter x 1

# INSTALLATION

## NOTICE:

Before assembling your sauna, carefully read the WARNING and ASSEMBLY TIPS sections of this manual. The illustrations provided are for reference purposes only and may not exactly match your specific sauna model. Parts and accessories shown may vary.



# INSTALLATION

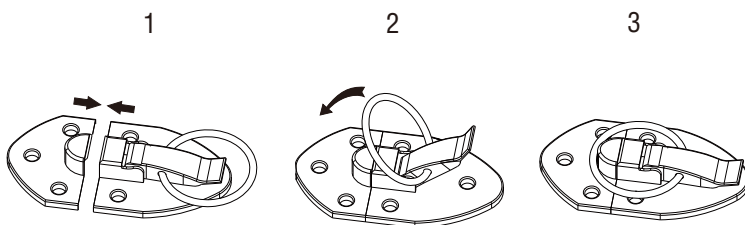
1. Find a suitable location to place the Bottom board [7], and refer to ASSEMBLY TIPS for details. Then attach the Back board [2] to the Bottom board by aligning the Back board with the front edge of the Bottom board. (Fig 1)



Fig 1

2. There are two types of buckles used throughout the installation. Install them as shown. (Fig 2)

Outer buckle installation



Hanging buckle installation

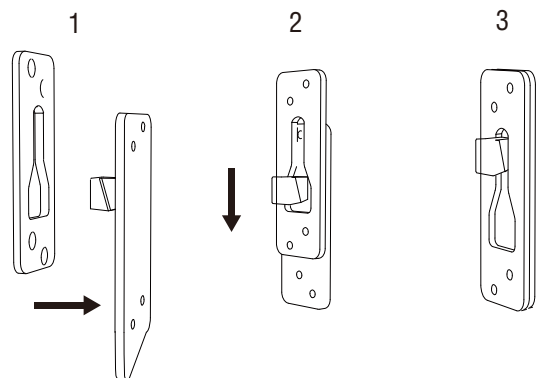


Fig 2

# INSTALLATION

3. Attach the Left board [5] to the Back board by aligning the buckles and sliding the Left board downward to lock it into place. (Fig 3)



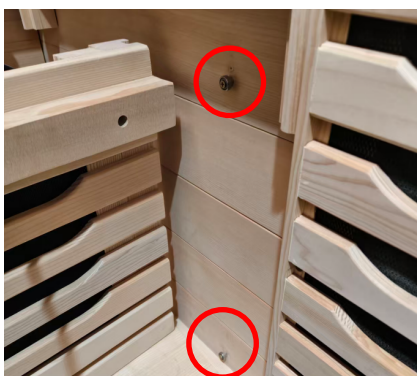
Fig 3

4. Attach the Right board [9] to the Back board by aligning the buckles and sliding the Right board downward to lock it into place. (Fig 4)

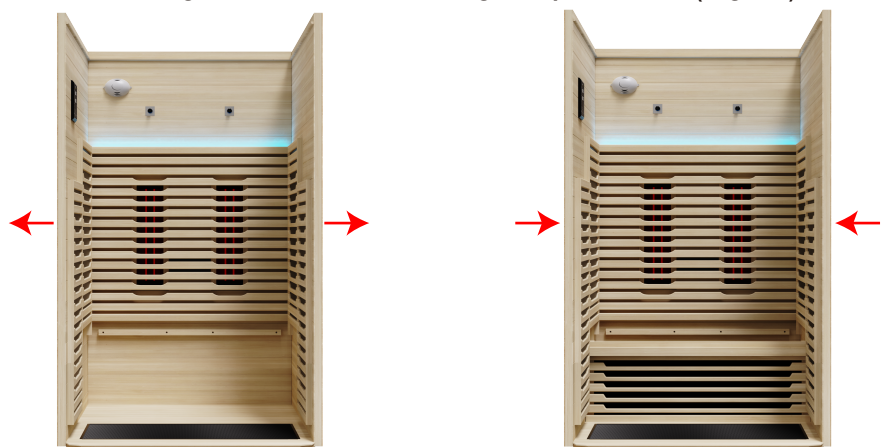


Fig 4

5. There are two positioning bolts on the inner sides of both the Left Board and the Right Board. (Fig 5a) Move each board slightly outward, align the side rails of the Bench Front Board [6] with the four bolts. (Fig 5b) Then return the Left Board and Right Board to their original positions. (Fig 5c)



a



b

c

Fig 5

# INSTALLATION

6. Connect the cable behind the Bench Front Board as shown. The heater cable on the Bottom Board needs to be connected to the DC adapter. (Fig 6)



Fig 6

7. Place the Bench [4] on the Bench Front Panel. (Fig 7)

There are corresponding bench support positions below the heater on the Back Board. First, place the rear end of the bench on the supports, then position the front end on the Bench Front Board.

8. Install the Left Square and Right Square [8] at the front ends of the Left Board and Right Board, respectively. (Fig 8)

9. Attach the front board [10] to the Left Square and Right Square by aligning the buckles and sliding the front board downward to lock it into place. (Fig 9)



Fig 7



Fig 8



Fig 9

# INSTALLATION

9. Unscrew and remove the Duster Cover [1] from the top of the Top board [4], lead all wires in the sauna up to the top. Install the Top board, allowing the wires to pass through the groove. (Fig 10)  
Every connection cable or plug has a corresponding pair, find male and female with the same label (like "Control") and plug in correctly. (Fig 11)

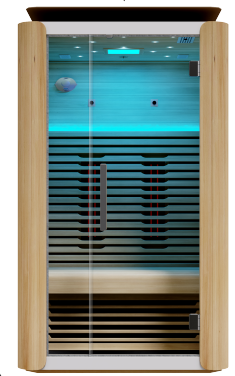
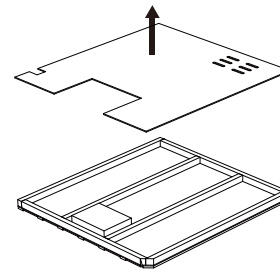


Fig 10



Fig 11

10. Locate the "12V Output" wire from the Control Box on the Top Board, pass it through the hole in the Back board, and connect it to the Oxygen Ionizer (independent part).  
Use an electric drill to secure the Oxygen Ionizer to the Back board with self-tapping screws (3\*25). (Fig 12)



Fig 12

11. Use self-tapping screws (5\*50) to secure the Top board through the pre-drilled holes around its edges. Then place the Duster Cover on Top Board, screw it again. (Fig 13)

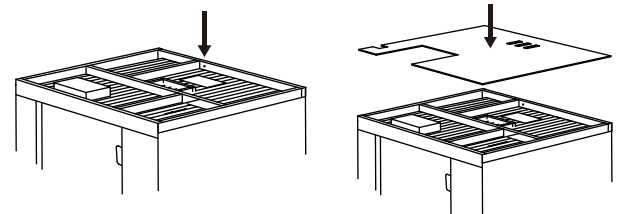


Fig 13

12. (Optional) Install the Newspaper and book rack on the inner side of Right Board as shown, and screw it with self-tapping screws (3\*35). (Fig 14)

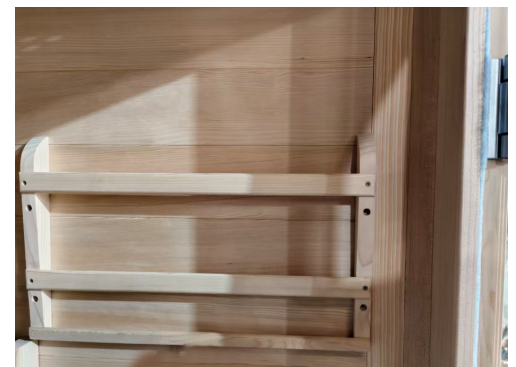


Fig 14

# INSTALLATION

13. Install the Handles[11] as figure shown. The metal handle is for the outside of the glass door.  
(Fig 14)

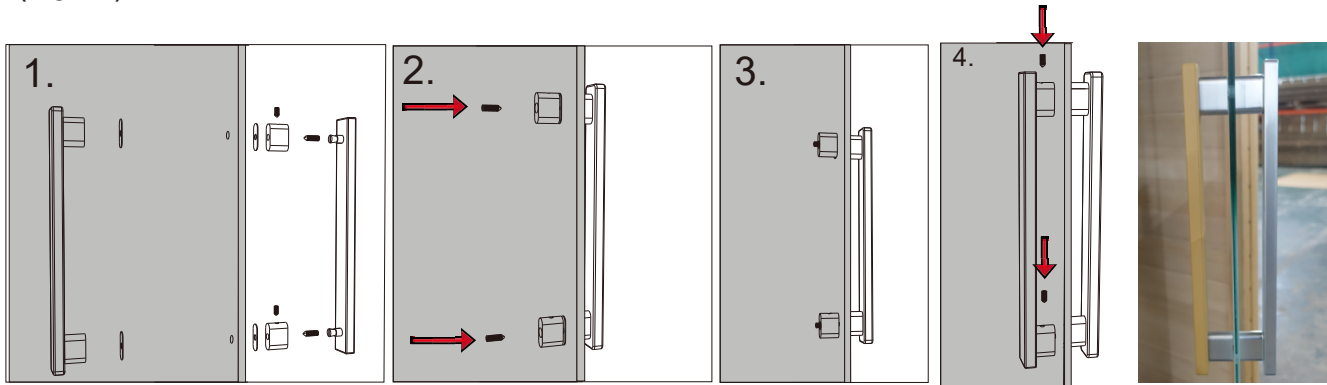


Fig 14

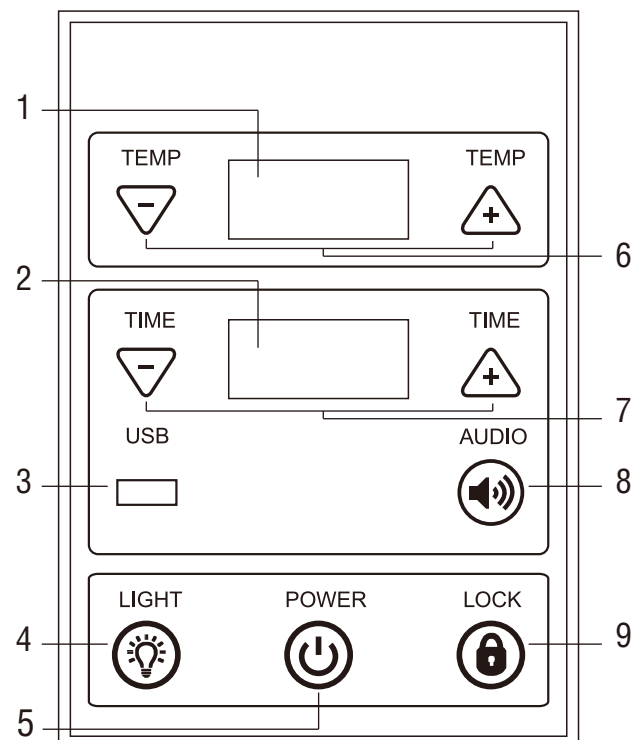
14. Plug the main power cord into a dedicated outlet.

**NOTICE:** The power outlet must be dedicated to the sauna—do not share it with other appliances.

# INSTRUCTIONS FOR USE

Congratulations, the assembly of the sauna is now complete, Please review instructions, warnings & suggestions before using.

- 1 Temperature display screen  
Display the temp in sauna room, If temp is lower than 86°F (30°C), it shows “LO”.
- 2 Timer display screen  
If timer is activated, display the countdown time.
- 3 USB port  
Plug in USB drive, use Audio function to play the music in USB drive.  
**NOTICE:**  
1. The partition format of USB drive require FAT32.  
2. MP3 audio should be placed in the root directory.
- 4 Light button  
Press the button to turn on/off the light, the indicator light will show the ON/OFF status of the light.  
If the indicator is on, press the button 5s will turn to lamp adjust mode, Timer display will show “2n”,



# INSTRUCTIONS FOR USE

## 4 Light button(Continued)

in this mode, the ON/OFF status of color light can be adjusted:

- ( 1 ) Press “Time-” to turn ON/OFF color light.
- ( 2 ) If the color light is on, short press light button to change the color.
- ( 3 ) No operation for 8s quits the light adjust mode.

## 5 Power button

Press and hold this button to switch heater ON / OFF.

## 6 Temp control

Press TEMP- and TEMP+ to adjust the heater temperature.

Temperature range is 86-149°F [ 30-65°C ], press once adjust 5°F [ 1°C ].

Celsius/Fahrenheit display switch: Press “TEMP-” and “LOCK” for 5S.

## 7 Timer control

Touch the “TIME+” and “TIME-” buttons to set the timer.

## 8 Audio control

The sauna can play music or radio, press to audio adjust status.

In audio status, indicator will on, Temp display show audio source, Timer display show volume(“Db”, range 01-30), press “TIME+” or “TIME-” to adjust volume, press audio button for switch audio source. No operation for 8s quits the audio adjust mode.

Bluetooth: Temp display shows “BLU”. Use devices that support Bluetooth audio playback(e.g. smartphone), find the bluetooth device called “SaunaSpa”, click to connect. If connect successful, press “TEMP+” and “TEMP-” to switch previous / next music.

NOTE: During bluetooth match, cannot switch audio source or turn ON/OFF another function.

USB drive: Temp display shows “USB”, press “TEMP+” and “TEMP-” to switch previous / next music.

FM Radio: Temp display shows frequency, time display shows “VOL”. Press “TEMP+” and “TEMP-” to adjust FM frequency (85.7-108.0Mhz).

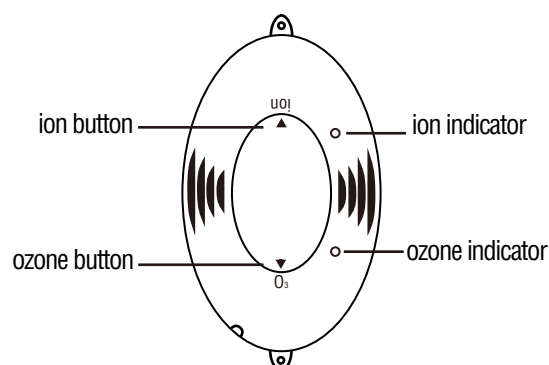
OFF: Audio function will turn off.

## 9 Button lock function

Long press the button for 5s to lock / unlock the control panel.

## Oxygen ionizer

1. Press ion button to turn ON/OFF ion function.
2. Press ozone button to turn ON/OFF ozone function.



# INSTRUCTIONS FOR USE

## Tips

1. The speaker is on the bottom of Top board, the audio quality is even better in the sauna.
2. Control box may be hot during sauna session, do not cover.
3. Ceiling vent can be adjusted in the sauna.
4. When activated, the ozone/ionizer may produce a distinct odor.
5. If the radio audio quality is poor, try to adjust the antenna(on Top board).

# SUGGESTIONS

## Before using

1. Please be sure to follow the instruction manual before operation.
2. Taking a hot shower or bath prior to starting your sauna session will help promote perspiration.

## During using

1. STAY HYDRATED! Remember to drink plenty of water before, during, and after using the sauna.
2. A normal sauna session should last 30 minutes or less.
3. Perspiration will usually begin within 15–25 minutes.
4. Open the ceiling vent or door to allow fresh air into the sauna.

## After use

1. Always remember to unplug your sauna after each use.
2. Open the door to let the heat and moisture dissipate and keep the sauna cabin dry.
3. Make sure to wipe any sweat from the sauna walls and surfaces. We recommend using a towel.

## Clean wood parts

1. Use a wrung-out wet towel to wipe down the outer and inner surfaces of the cabin. Additionally, we recommend using a small vacuum cleaner on the interior surfaces.
2. Avoid using any organic-based cleaners such as gasoline or alcohol on the wooden surfaces.
3. Avoid using any sharp or abrasive materials to prevent scratching the wood.

## Cleaning glass parts

1. Use soft materials such as a microfiber cloth to wipe the glass.
2. Stubborn stains can be removed with a damp cloth, then dried with a clean, dry cloth.
3. Avoid using any sharp or abrasive materials to prevent scratching the glass surfaces.

## Transportation and storage

1. Avoid exposure to water, snow, or strong impact during transportation.
2. Do not store the sauna in a humid environment.
3. In dry climates (such as northern regions), keep the wooden parts slightly moist — for example, wipe them occasionally with a wrung-out wet towel.

# TROUBLESHOOTING

- Always cut off the power of the sauna and let it cool down before maintenance.
- Repairs to the electrical components of the sauna should only be performed by qualified service technician.
- Unauthorized repairs will void the warranty, please contact SaunaSpa service immediately.

## 1. No Heat Coming From Some Of The Heaters

**Solution:** Check that the Power Cord is plugged into the outlet, make sure all heater cords are properly connected, including the cord to the heater on the floor. Check the heater cords on Top board, make sure they connected to the control box properly.

**Solution:** If some heaters are working, then the not working heater may have been damaged. don't continue to operate. Contact SaunaSpa for replacement parts.

**Solution:** If the heaters are not working but the control panel doesn't display the error code, the temperature sensor may not be plugged properly or maybe damaged. Contact SaunaSpa for replace sensor, then remove the duster cover, find the temperature sensor wires on top board and remove it, put the new sensor down the vent, make sure the sensor is straight down under the vent so that it is now inside the sauna. Then turn on the sauna and wait 5 minutes to confirm if the heater are generating heat.

## 2. Control Panel Malfunctioning

**Solution:** The control panel can turn on, but cannot off or no response when button on panel are pressed. The problem may be cause by connection. Find the "Control" wire on the top board, disconnect the wire, then check the pins to make sure they are not bent, and reconnct the "Control" wire harness. Turn on the sauna and check the operation are now responding.

**Solution:** If the control panel is showing no sign of power, it may have been damaged, contact SaunaSpa for help.

## 3. Control Panel Show Error Code

**Code "HH":** The temperature of sauna over than 167°F [ 75°C ], restart the sauna until the temperature of sanua lower than 149°F [ 65°C ].

**"E0" / "E1" :** The sensor of temperature is broken, contact SaunaSpa for replacement parts.

**Code "LO":** The temperature in sauna is lower than 86°F [ 30°C ], it's not a malfunction.

## 4. Intentional Rear Wall Warp

**Solution:** The back board is intentionally warped as part of sauna design, this add strenth to the sauna structure once the sauna is assembled. Read Step 5 of the Installation.

# TROUBLESHOOTING

## 5. Wall Outlet Melting

**Solution:** 1. A common problem with wall outlets is loose wiring on the connection points of the terminals of the receptacle, a loose wire will also make for a bad connection and cause an unusual amount of heat buildup, loose connections can also cause sparking in the junction box that could result in arcing.

2. Contact qualified service technician to replace the wall outlet.
3. If the power cord is damaged, contact SaunaSpa for help, the power supply may need to be replaced.

## 6. Dedicated Power Outlet

**Solution:** 1. Use the dedicated line, the power outlet is the only receptacle on the line to the breaker in electric panel box.

2. If you can't use dedicated line for sauna, try to cut off other electrical appliances on the same line with sauna when it is operating.

## 7. Heater Under Bench Heat Coming Slow

**Solution:** For safety, the heater under bench will have lower power than other heater, it's not a malfunction.

## 8. Speaker Malfunctioning

**Solution:** Check the connection wire of speakers on the top board, replug the wire then make sure the speaker is work.

**Solution:** The speakers maybe damaged, contact SaunaSpa for replacement parts.

## 9. Color Lighting Malfunctioning

**Solution:** If color light is not working, the issue with the light may have to do with connection(s) on the top side of the light fixture. Disconnect the wire connection of light on the top board, then reconnect the connection, make sure it's snug and tight.

Test the light again, if the light is still having issues, contact SaunaSpa for help.

## 10. Cannot Use Bluetooth

**Solution:** 1. Check bluetooth switch in bluetooth device (eg. mobilephone, MP3), and make sure it connect bluetooth device called "SaunaSpa" successfully.

2. Adjust volume on device and control panel on sauna when the device is playing music.
3. Bluetooth devices are not compatible with sauna, try another device.

## 11. Cannot Use USB or FM

**Solution:** 1. If use the USB Drive, check that the partition format of USB Drive, FAT32 is required.

2. If use the FM, try to adjust the location of the sauna.
3. Adjust volume on control panel on sauna when the sauna is playing music or radio.

