

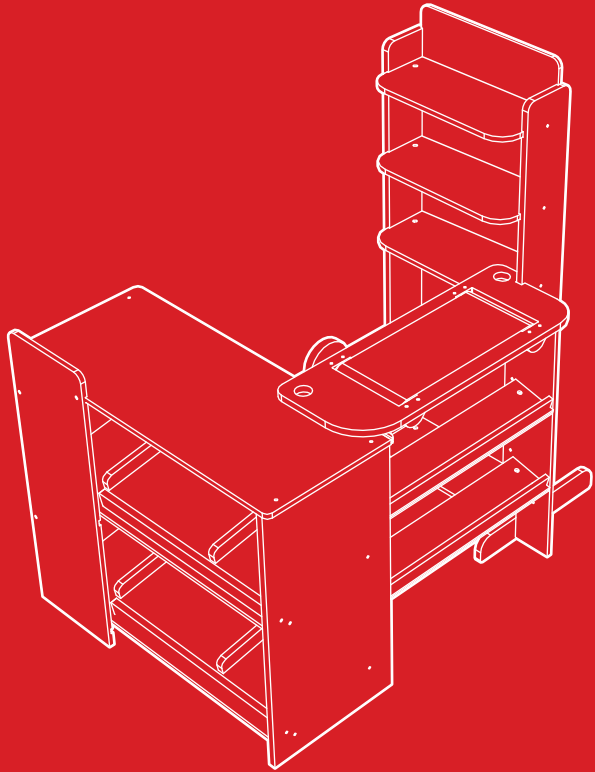

bestchoiceproducts



INSTRUCTION MANUAL

Kids Supermarket Playset



bestchoiceproducts

As shoppers, we're always trying to find the perfect balance between quality & value. At BCP, we believe we've achieved that. Our diverse catalog of everyday essentials is tailored especially to our customers & guaranteed to hit that sweet spot of high quality & low price.

— Always. —

! NOTICE

Please retain these instructions for future reference.

- This product requires adult assembly and supervision when in use.
- This product is intended for indoor use only.
- Do not stand on or use any part of this item as a step ladder.
- Firmly secure all bolts, screws and knobs before use.
- Reconfirm that all bolts, screws, and knobs are secure every 90 days.
- Do not use or store this item in the proximity of open flame or flammable/combustible chemicals.
- Do not use this product to hold or store hot materials.
- If any parts are missing, broken, damaged, or worn, stop using this item until repairs are made and/or factory replacement parts are installed.
- Do not use this item in a way inconsistent with the manufacturer's instructions as this could void the product warranty.
- This product contains small parts. May result in choking hazard for children under 3 years.
- To wipe down the furniture, use a damp cloth. Then, wipe it down once more with a dry cloth.

TOOLS REQUIRED



3+

3 YEARS
OLD AND UP

HARDWARE

1

SCREWS



63 PCS

2

BARREL NUT
& BOLT SET



2 PCS

3

NUT & BOLT SET



2 PCS

PARTS

A1

PANTRY BACK (TOP)

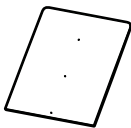

1 PC

A2

PANTRY BACK
(BOTTOM)

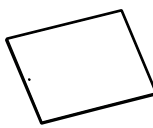

1 PC

B1

PANTRY SIDE (LEFT)

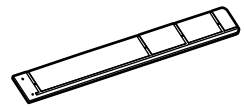

1 PC

PARTS

B2 PANTRY SIDE (RIGHT)

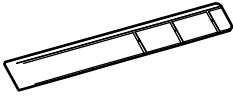

1 PC

C1 PANTRY SHELF



3 PCS

C2 PANTRY MIDDLE SHELF



1 PC

D PANTRY FOOT

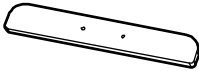

2 PCS

E PANTRY BASE RUNNER



1 PC

F PANTRY CONNECTOR PANEL

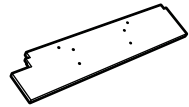

1 PC

G COUNTER SHELF



2 PCS

H COUNTER SHELF DIVIDER

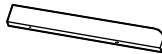

2 PCS

I COUNTER SHELF FRONT



2 PCS

J COUNTER BACK PANEL

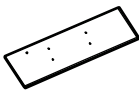

1 PC

K CHECKER SHELF



2 PCS

L CHECKER SHELF FRONT



2 PCS

PARTS

M1

COUNTER SIDE (LEFT)

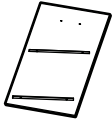

1 PC

M2

COUNTER SIDE (RIGHT)

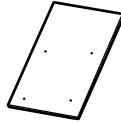

1 PC

N

KNOBS



2 PCS

O

COUNTER FRONT

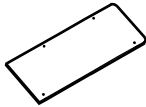

1 PC

P

COUNTERTOP

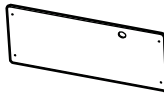

1 PC

Q

CONVEYOR BELT

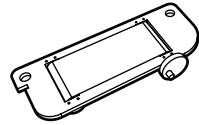

1 PC

PANTRY ASSEMBLY

1

Locate the part A2 pantry back and insert into the parts B1 & B2 pantry sides.

Insert the part A1 pantry back into the pantry sides.

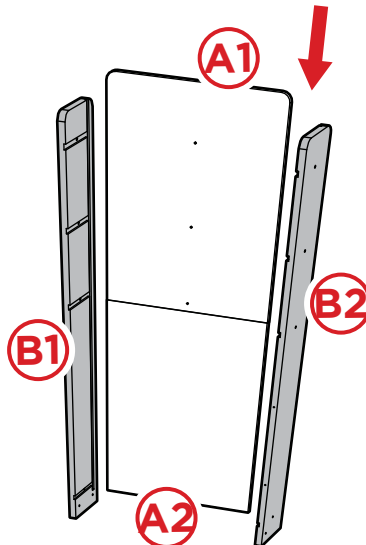

PANTRY ASSEMBLY

2

Locate three part C1 pantry shelves and insert into the corresponding grooves, then secure with nine part 1 screws.

Attach two part D pantry feet to the pantry sides with two part 1 screws and two part 2 barrel nut and bolt sets. Attach the part E base runner with two part 1 screws.

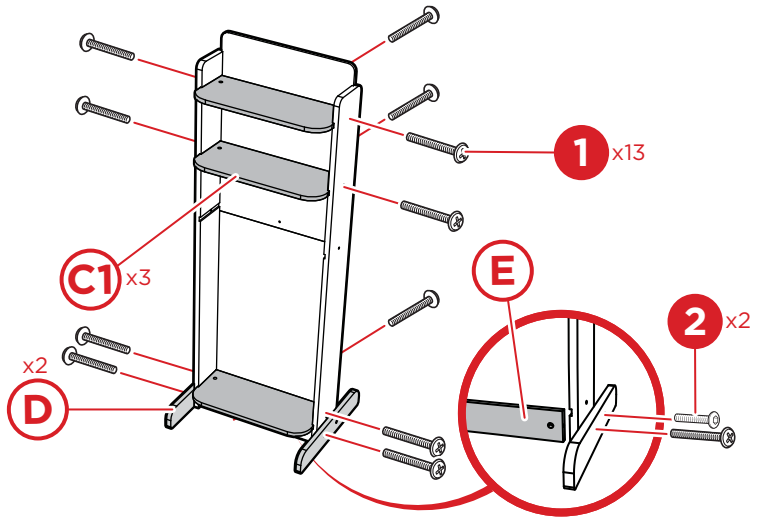

3

Locate the part C2 pantry middle shelf and attach with three part 1 screws.

Locate the part F pantry connector panel and attach it to the part B2 pantry side with two part 1 screws.

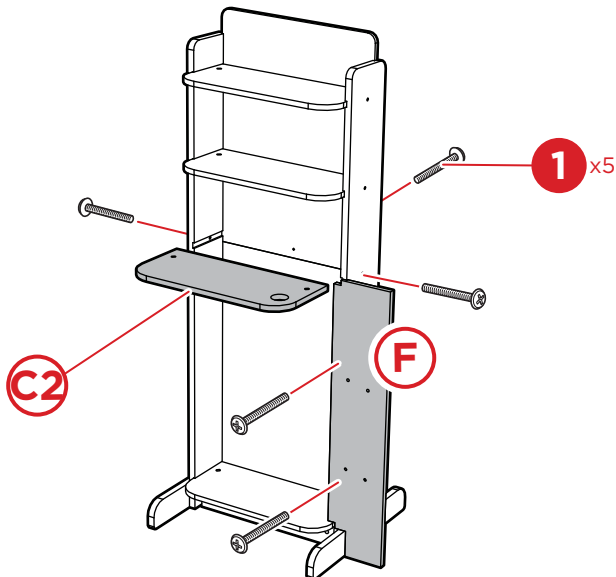

COUNTER ASSEMBLY

1

Locate the part G counter shelf and attach two part H shelf dividers with four part 1 screws.

Attach one part I counter shelf front with three part 1 screws. Repeat to assemble the second counter shelf, and set aside.

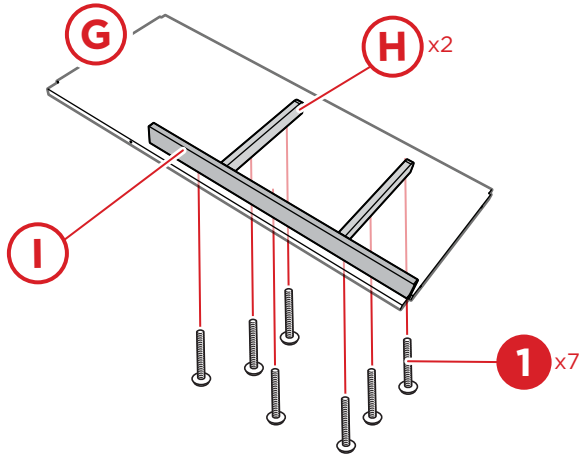

2

Attach one part L checker shelf front to a part K checker shelf with two part 1 screws. Repeat to assemble the second checker shelf.

Attach the checker shelves to the part J counter back panel with four part 1 screws, then set aside.

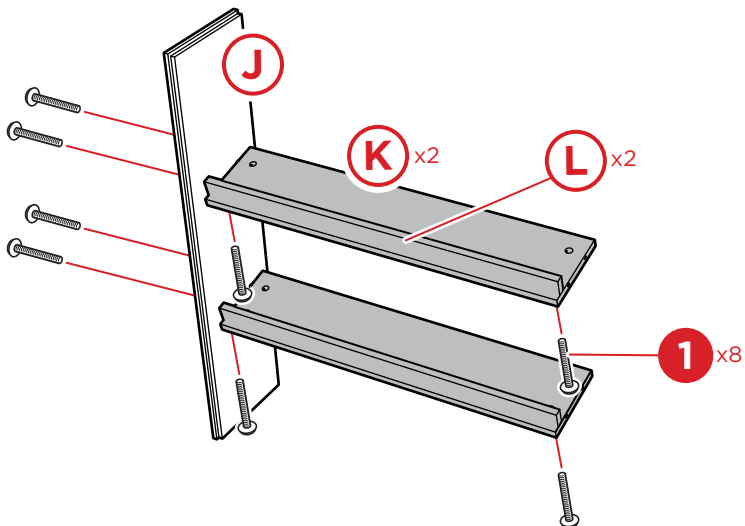

COUNTER ASSEMBLY

3

Attach one counter shelf assembly to the part M1 and M2 counter sides with four part 1 screws. Repeat to attach the second shelf assembly.

Attach two part N knobs with two part 1 screws. Attach the part J counter back panel with one part 1 screw.

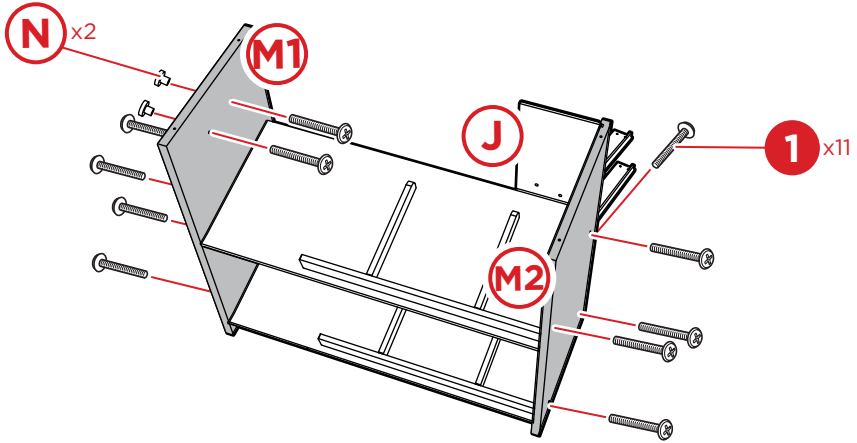

4

Attach the part O counter front to the counter assembly with four part 1 screws.

Attach the part P countertop with four part 1 screws.

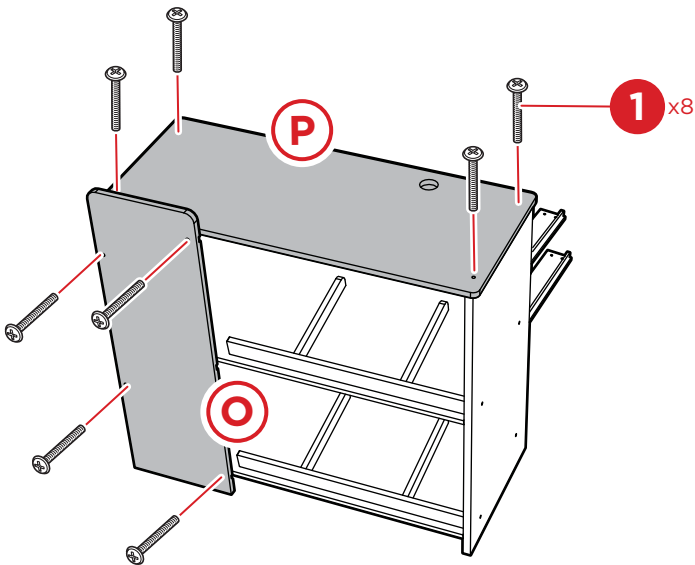

FINAL ASSEMBLY

1

Attach the checker shelf assembly to the pantry connector panel with four part 1 screws.

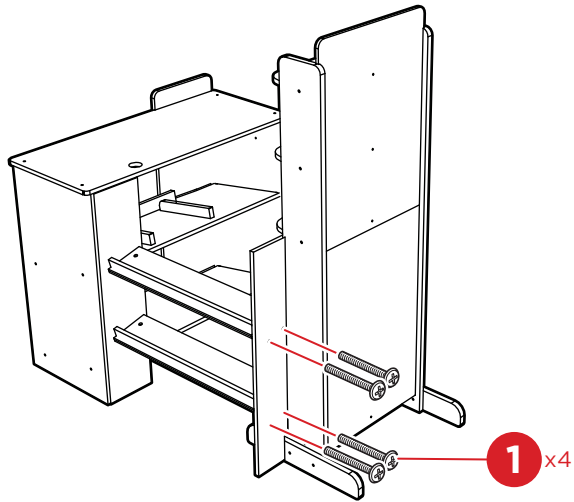

2

Locate the part Q conveyor belt and attach with two part 3 nut and bolt sets.

This product is now assembled.

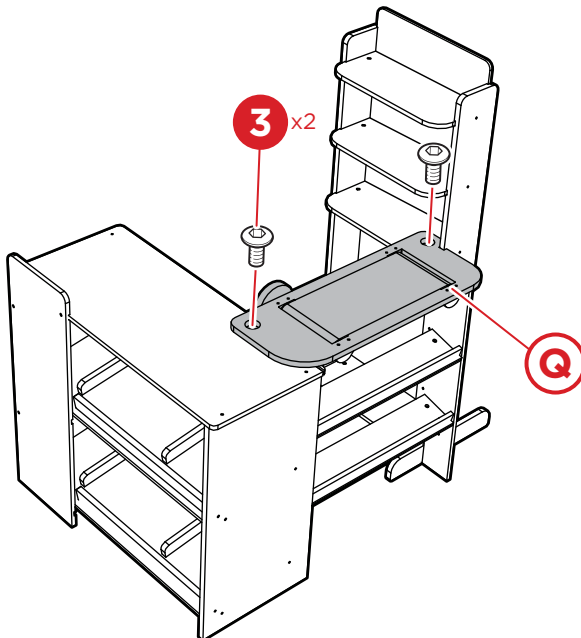



bestchoiceproducts

Check out more great products:

[bestchoiceproducts.com](https://www.bestchoiceproducts.com)

Earn points while you shop. Join today!

bestchoiceproducts
rewards\$

Join | Earn | Redeem

Give your friends 15% off their first order! For each successful referral you'll receive 100 points.

bestchoiceproducts.com



HELP CENTER



Question about your product? We're here to help. Visit us at:

help.bestchoiceproducts.com



Product Assembly



Returns & Refunds

PRODUCT WARRANTY INFORMATION

All items can be returned for any reason within 60 days of the receipt and will receive a full refund as long as the item is returned in its original product packaging and all accessories from its original shipment are included. All returned items will receive a full refund back to the original payment method. All returned items will not be charged a re-stocking fee.

All returned items require an RA (Return Authorization) number, which can only be provided by a Best Choice Products Customer Service Representative when the return request is submitted. Items received without an RA may not be accepted or may increase your return processing time. Once an item has been received by Best Choice Products, refunds or replacements will be processed within 5 business days.

All returns must be shipped back to the Best Choice Products Return Center at the customer's expense. If the reason for return is a result of an error by Best Choice Products then Best Choice Products will provide a pre-paid shipping label via email. Boxes for return shipping will not be provided by Best Choice Products, and is the customer's responsibility to either use the original shipping boxes or purchase new boxes.

Pictures may be required for some returns to ensure an item is not damaged prior to its return. Items returned are not considered undamaged until they are received by Best Choice Products and verified as such. All damages to items are the customer's responsibility until the item has been received by and acknowledge by Best Choice Products as undamaged.

WARNING

Manufacturer and seller expressly disclaim any and all liability for personal injury, property damage or loss, whether direct, indirect, or incidental, resulting from the incorrect attachment, improper use, inadequate maintenance, unapproved modification, or neglect of this product.