

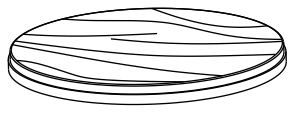

# ASSEMBLY INSTRUCTION

## ROUND SIDE TABLE WITH FAUX MARBLE TOP & SHELF

<b>A</b> Wood Top	<b>B</b> Bottom Frame	<b>C</b> Wood Shelf	<b>D</b> Stretcher D
 <p>1pc</p>	 <p>1pc</p>	 <p>2pcs</p>	 <p>2pcs</p>
<b>E</b> Stretcher E	<b>F</b> Stretcher F	<b>G</b> Bolt 1/4" x 1/2"	<b>H</b> Bolt 1/4" x 1-1/2"
 <p>1pc</p>	 <p>1pc</p>	 <p>8pcs</p>	 <p>4pcs</p>
<b>I</b> Screw 3/16" x 10mm	<b>J</b> Leveler 12mm	<b>K</b> Allen Wrench 1/4"	
 <p>6pcs</p>	 <p>4pcs</p>	 <p>1pc</p>	

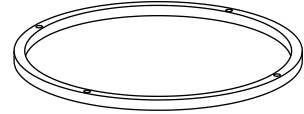
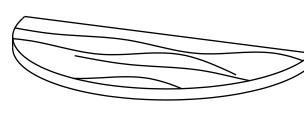
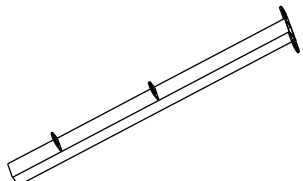
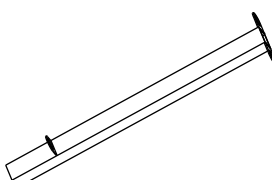
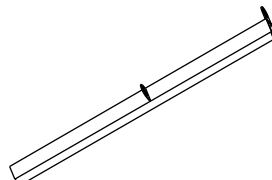
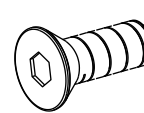
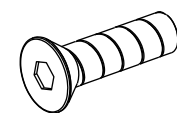
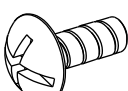

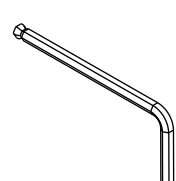
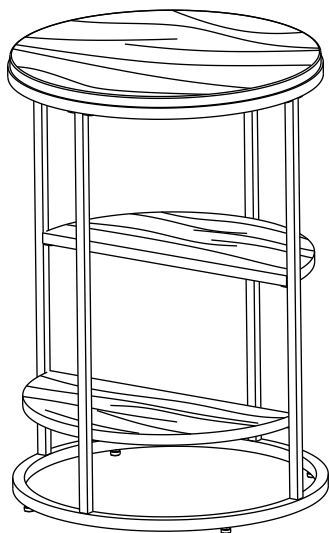
This page lists all the contents included in the box. Please take the time to identify the hardware as well as the individual components to this product. As you unpack and prepare for assembly, place the contents on a carpeted or padded area to protect them from damage.

**\*\*\* Do not tighten screws & bolts until the entire unit is completely assembled.**

**1**

Attach Stretcher (D), Stretcher (E) and Stretcher (F) to Wood Top (A) by Bolt (G) and Allen Wrench (K) as shown.

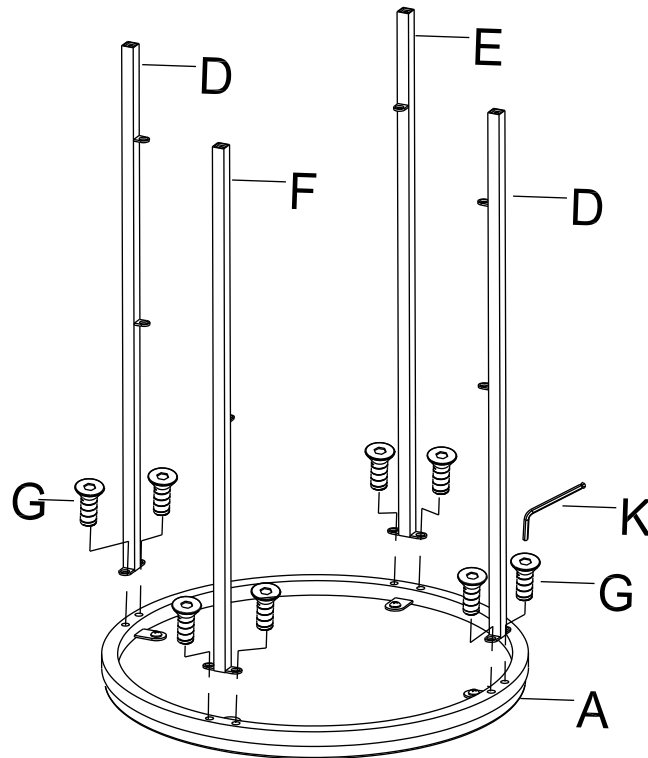

**2**

Attach Wood Shelf (C) to stretchers by Screw (I) as shown.

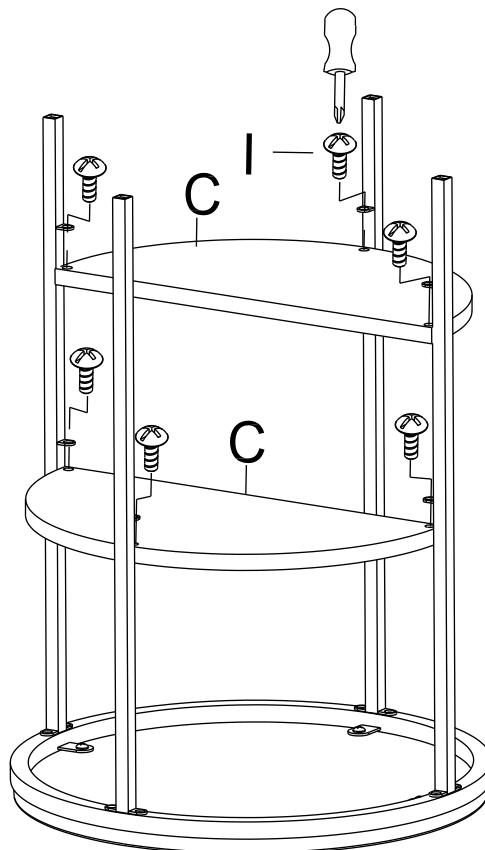

**3**

Attach Bottom Frame (B) to the bottom of stretchers by Bolt (H) and Allen Wrench (K). Then, attach Leveler (J) to Bottom Frame (B) as shown.

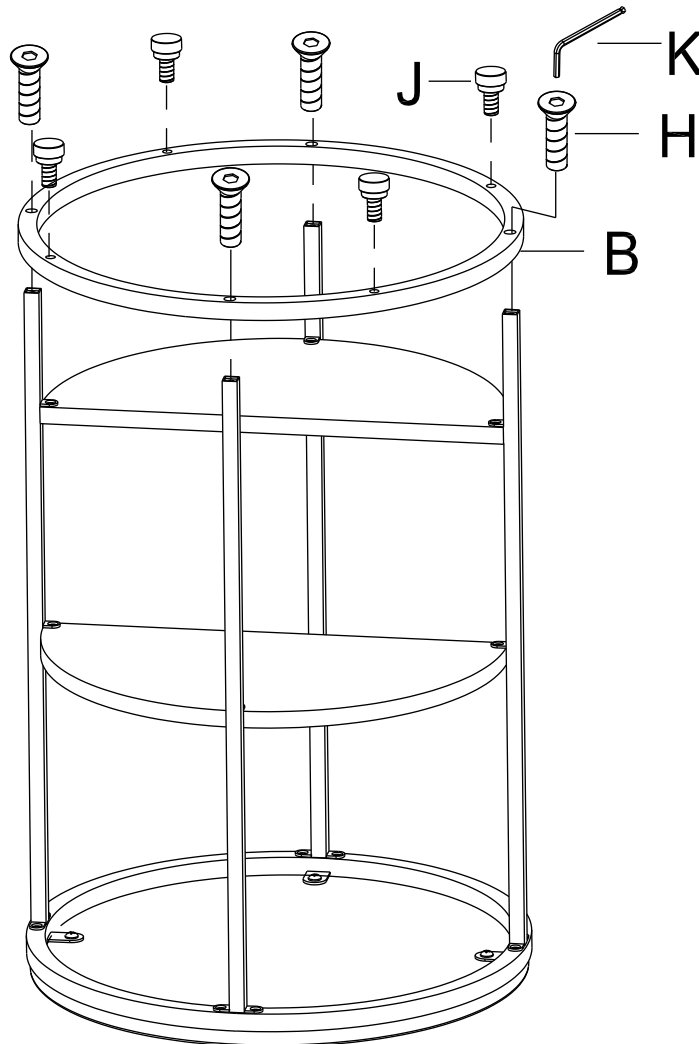

### Cleaning & Care

Treat surface with care. Surface is resistant to scratches but is not scratch resistant. Clean surfaces with a dry or damp soft cloth. Do not use abrasive cleaners. Hardware may loosen over time. Periodically check that all connections are tight.