

**WALKER EDISON**  
™

# Lee 2 Drawer Nightstand

SKU: LEEB4C  
LOT: **AAYYWW-XXX**

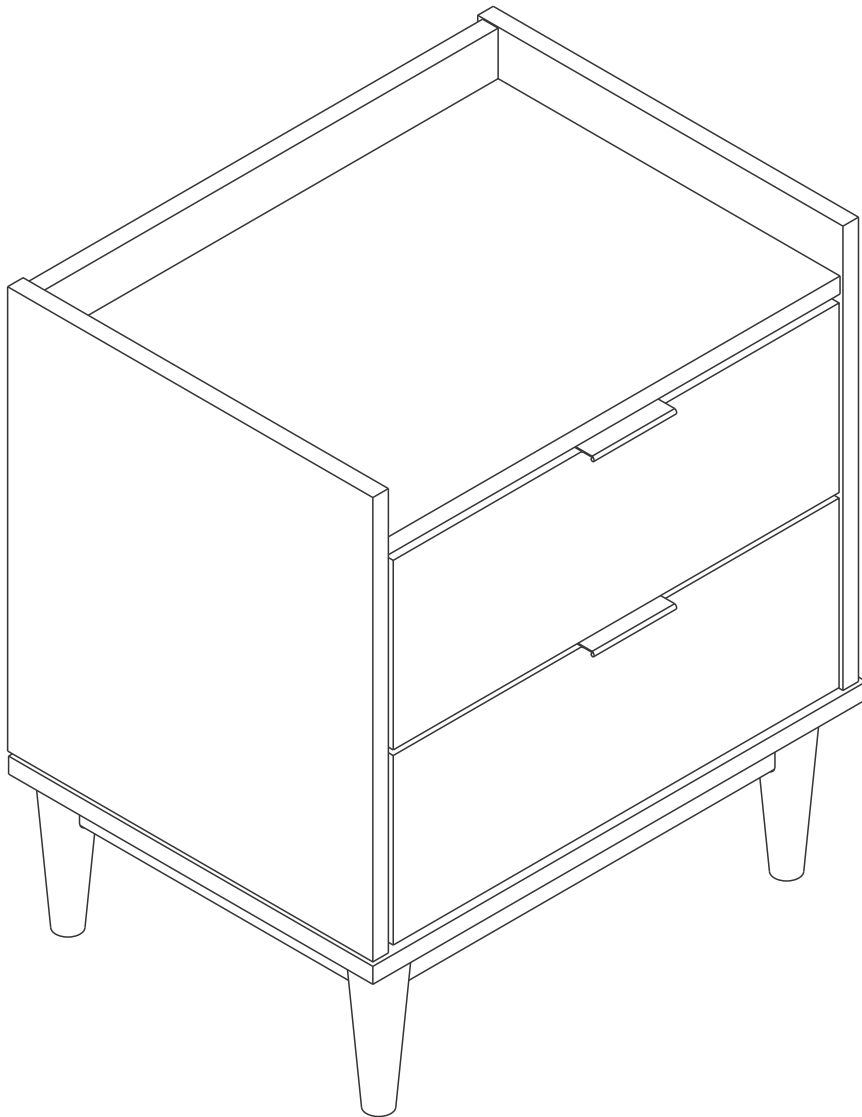

*For Residential Use Only*

Please visit our website for the most current instructions, assembly tips, to report damage, or request parts. [www.walkeredison.com](http://www.walkeredison.com)

# WE Time to get started

Set up a clean and soft workplace to avoid damage during assembly. You can use the box and internal protections as a cover. It also helps to double-check if you have got all the pieces and parts before diving into the assembly.

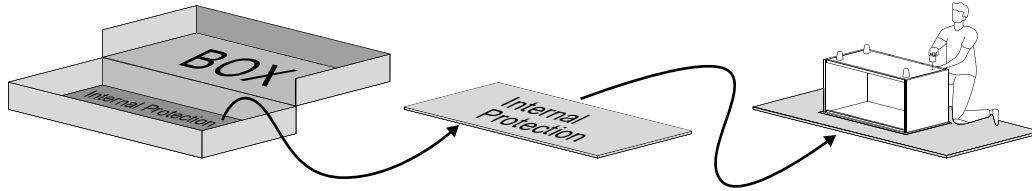

**Estimated time  
for assembly**

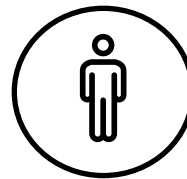

1 Person Build

**You can assemble  
it alone.**

But you can make  
it a team effort!  
Grab a friend for quicker,  
easier assembly.

## Tools Needed

Grab a Phillips head screwdriver to conquer this assembly.

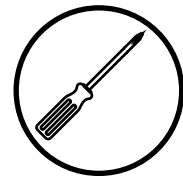

## Use power tools with caution

This furniture is made of Solid Wood and Composite Wood, soft materials. If you choose to use power tools, set it to the slower setting. Be careful! Power tools can cause cracking or damage to the furniture, they can also damage the hardware if misused. Power tool damages are not covered by the Walker Edison warranty

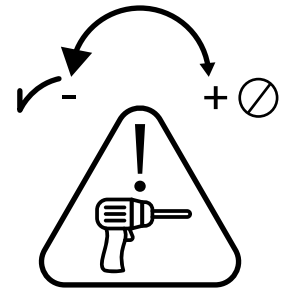

## Slide care

Your furniture has highly durable wooden sliders. From time to time we recommend applying paraffin or standard candle wax to improve gliding of the sliders.

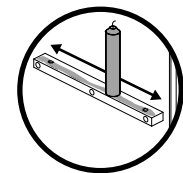

**Scan to get assembly tips and help!**







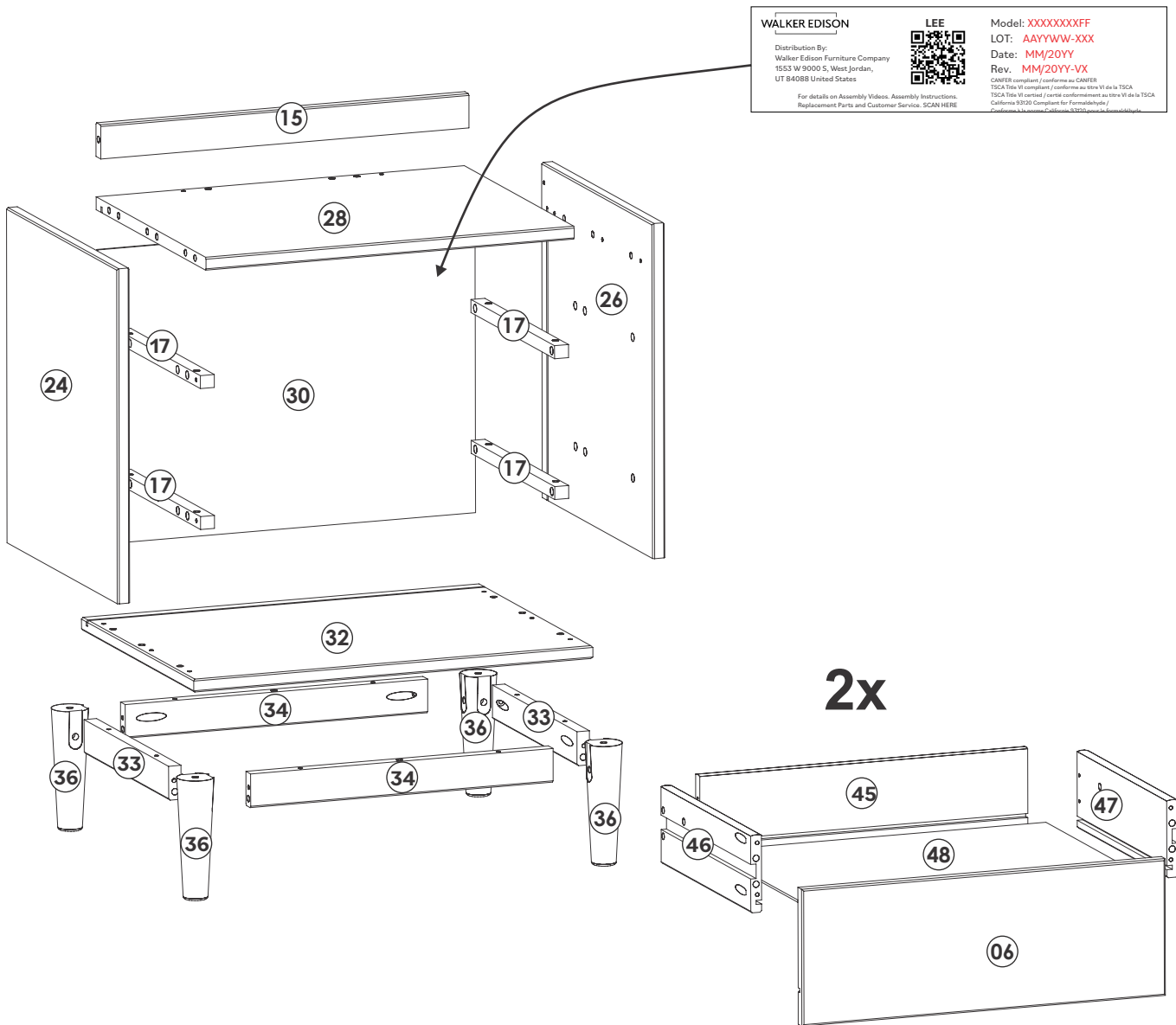

# WE Part List

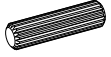
Part Number	Description	Quantity
06	Drawer Front	02
15	Top Crossbeam	01
17	Drawer Runner	04
24	Left Side Panel	04
26	Right Side Panel	01
28	Top Panel	01
30	Back Panel	01
32	Base Panel	01

Part Number	Description	Quantity
33	Bottom Side Crossbeam	02
34	Bottom Front Crossbeam	02
36	Leg	04
45	Drawer Back	02
46	Drawer Left side	02
47	Drawer Right side	02
48	Drawer Bottom	02

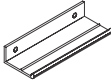

# WE Hardware List

Part	Size	Name	Quantity
A	 8x30mm	Wooden dowel	41
B	 10x20mm	Wooden dowel	12
C	 4,0x40mm	Screw	22
D	 3,0x12mm	Screw	04
E	 15x12mm	Cam lock	08
F	 5x24mm	Cam bolt	08
G	 3,5x30mm	Screw	18
H	 8x40mm	Wooden dowel	04
I	 4,0x25mm	Screw	12
J		Handle	02

The hardware quantities listed above are required for proper assembly.  
Extra hardware pieces may be included.

# Step 1

Let's start! Insert Wooden Dowel (B) into the Drawer Runner (17).

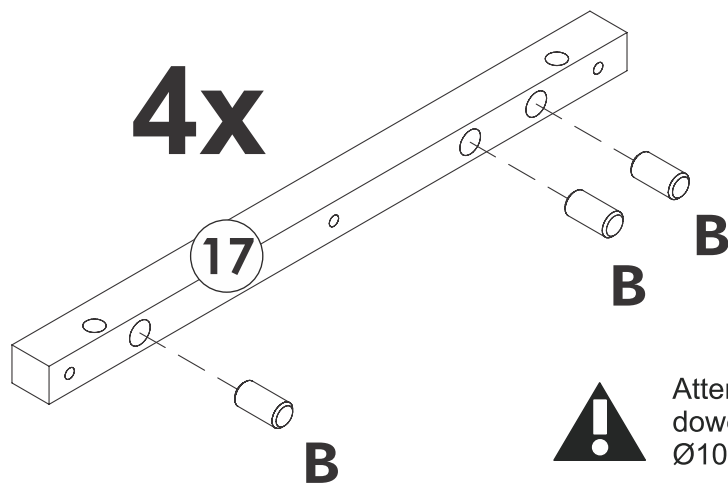
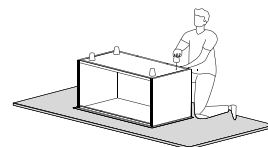

Attention to the  
dowel size:  
Ø10\*20mm

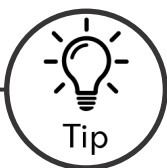
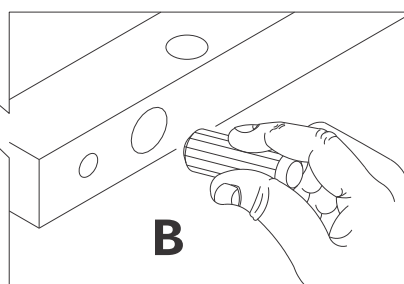
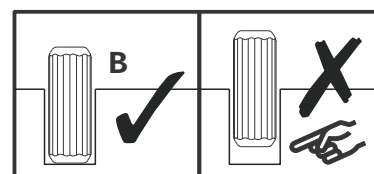

## Wood Dowels

Dowels are essential in furniture assembly  
to create strong, precise connections.

They ensure structural integrity, prevent shifting, and simplify alignment,  
resulting in sturdier, longer-lasting furniture.

Follow these steps:

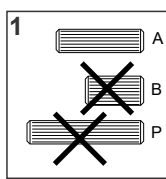

1: Select the appropriate size  
dowel according with step.

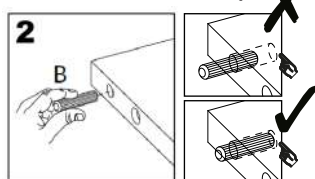

2: Insert into drilled hole and press  
firmly to ensure placement is set.

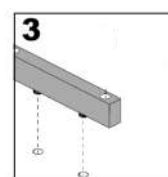

3: Align the dowel with corresponding  
piece and press together until secure.

# Step 2

Insert Wooden Dowel (A) into the Top Crossbeam (15), Left Side Panel (24), Right Side Panel (26), Top Panel (28), Bottom Side Crossbeam (33), Bottom Front Crossbeam (34), Drawer Left Side (46) and Drawer Right Side (47).

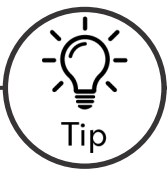
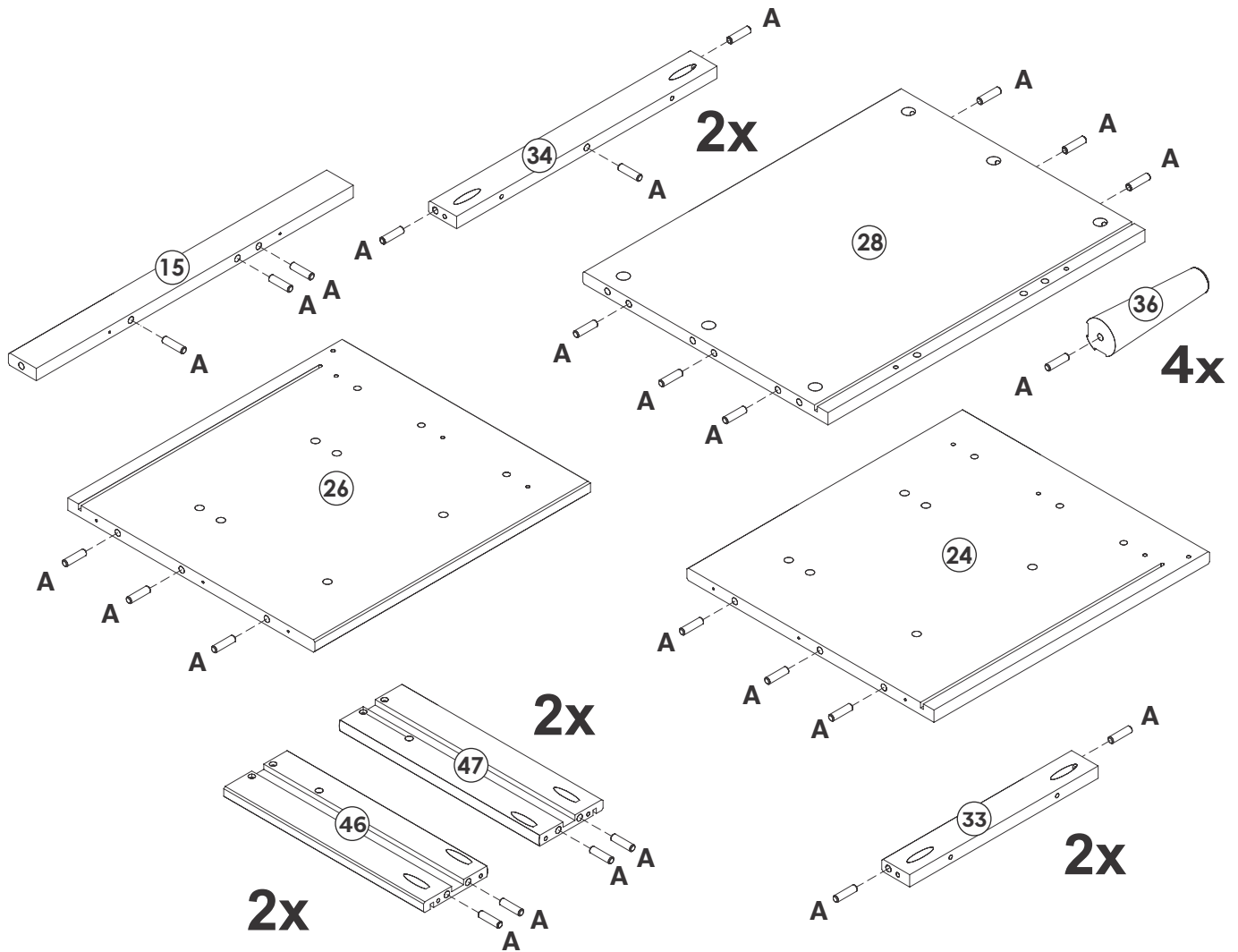

Tip

To keep your product looking its best and scratch-free, try assembling it on a soft surface like carpet or a blanket. This helps prevent any accidental scratches and keeps your furniture in top shape!

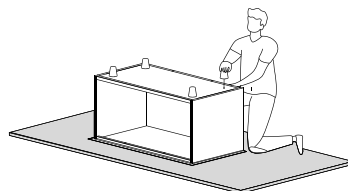

# Step 3

Attach Cam Bolt (F) into the holes in Left Side Panel (24) and Right Side Panel (26) with a Phillips head screwdriver.

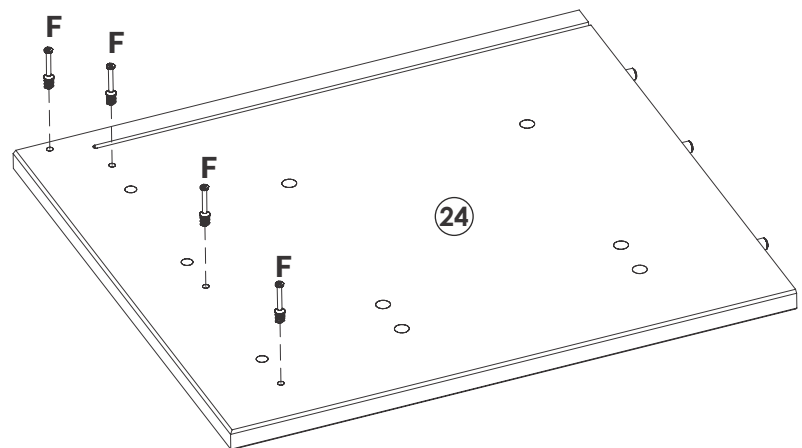
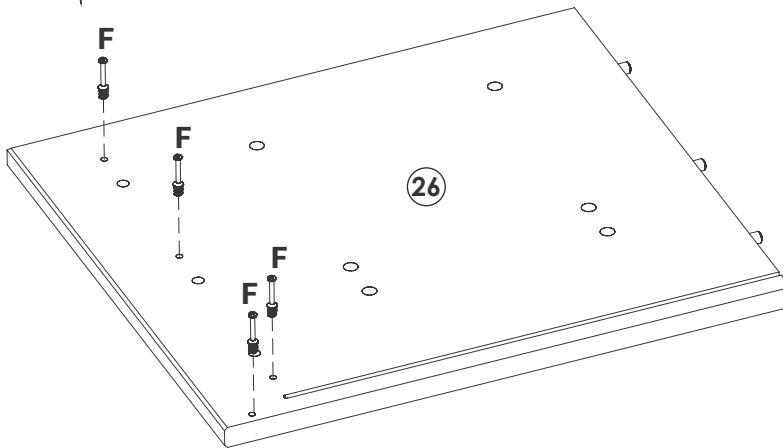
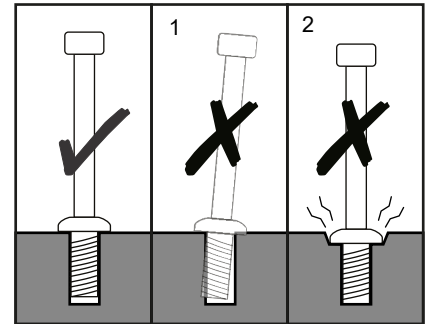
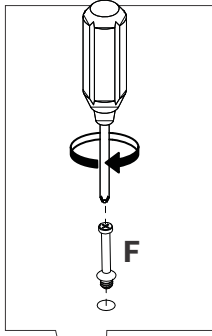
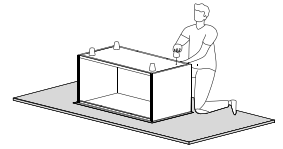

# Step 4

Secure the Drawer Runner (17) to Left Side Panel (24) and Right Side Panel (26) with Screw (I) and a Phillips head screwdriver.

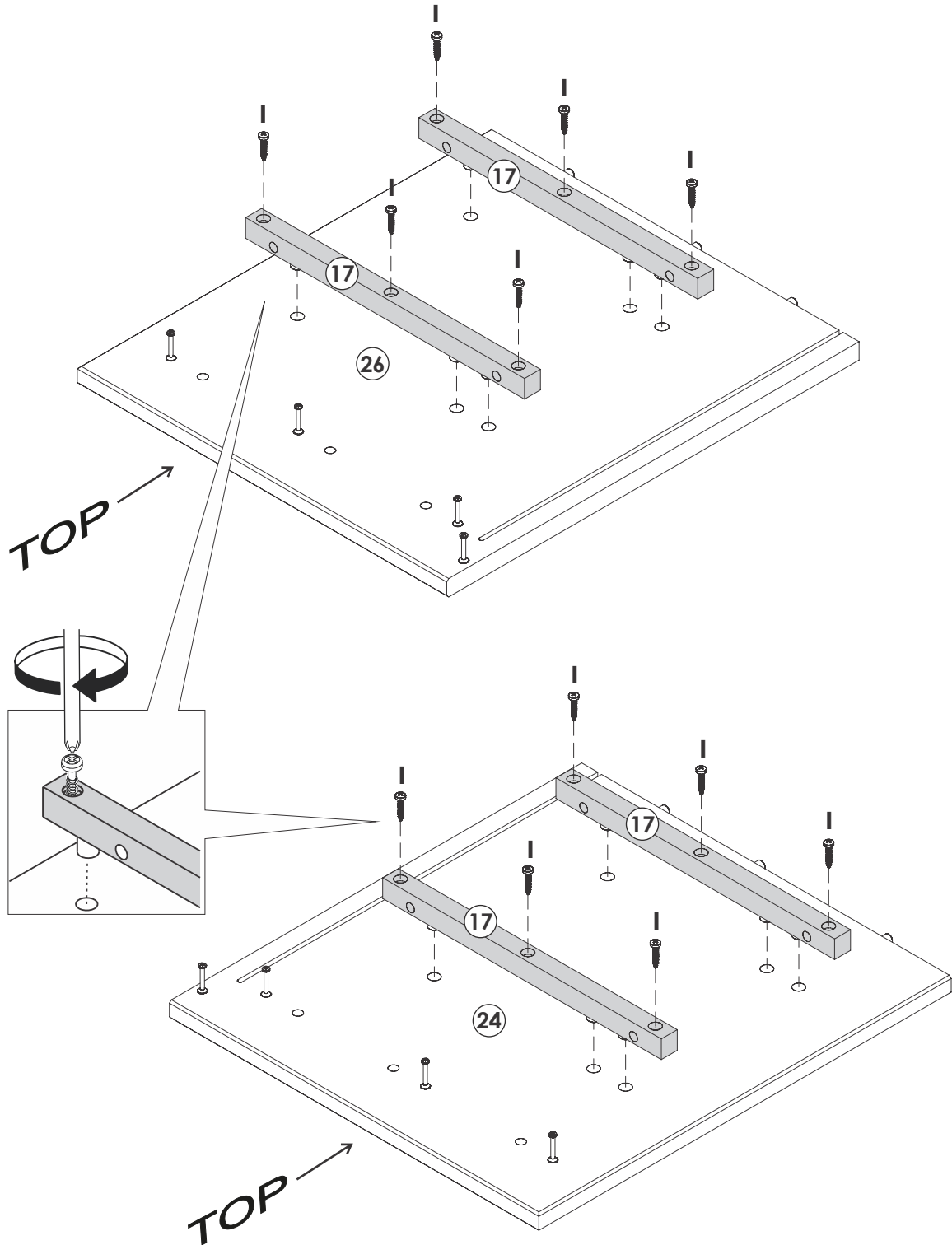
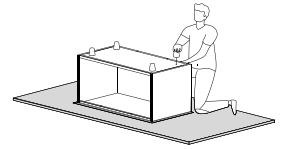



# Step 5

Secure Top Panel (28) to Top Crossbeam (15) with Screw (G) and a Phillips head screwdriver.

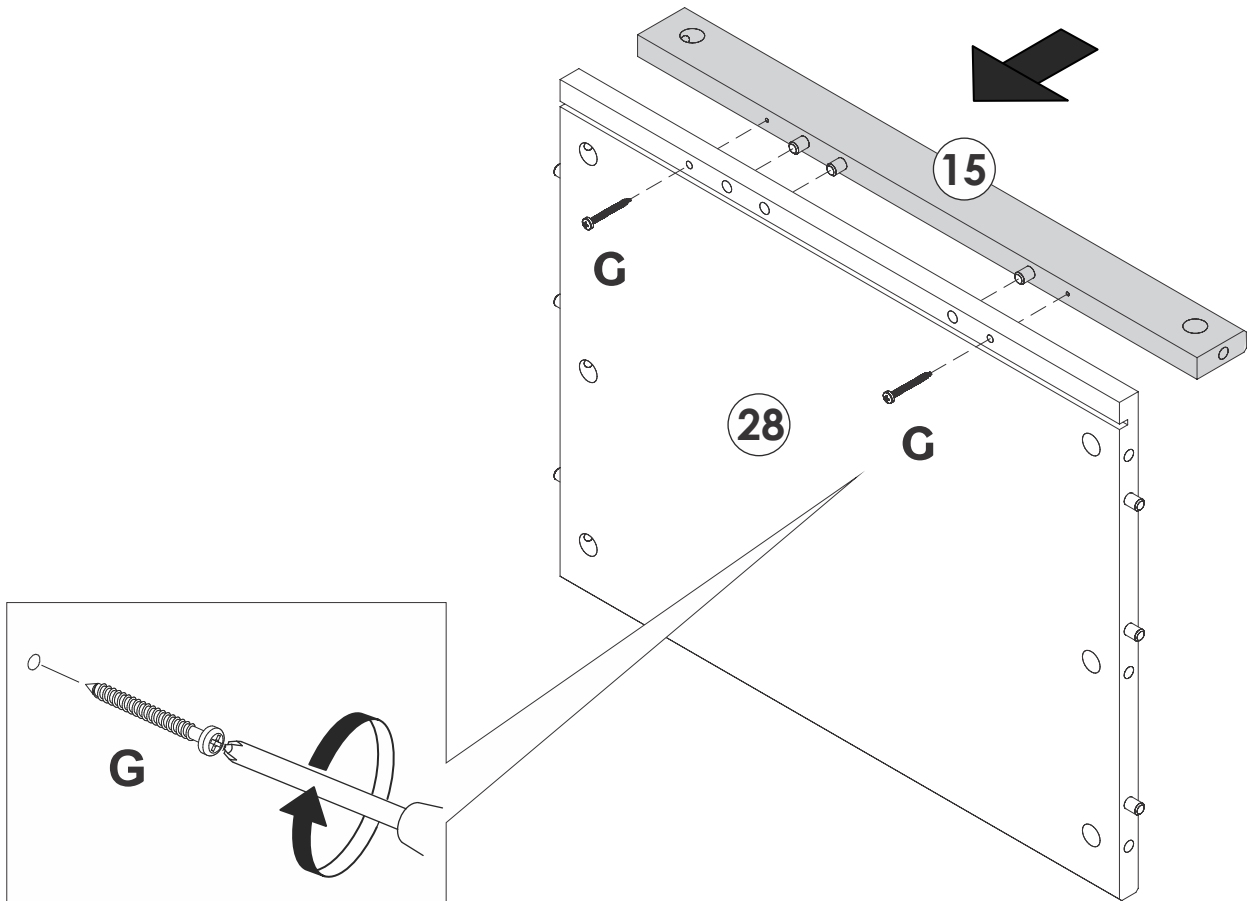
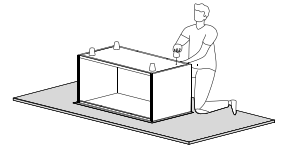

STEP READY

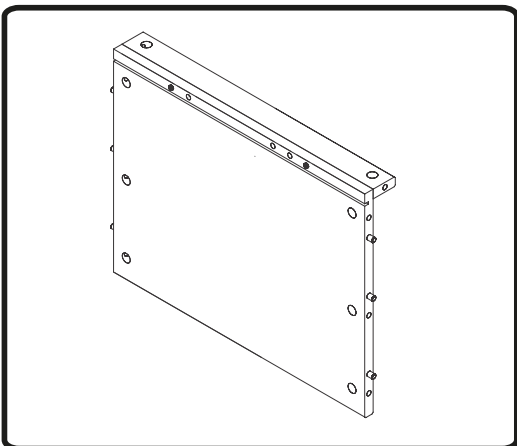

# Step 6

Join Top Panel (28) and Top Crossbeam (15) to Right Side Panel (26). Insert Cam lock (E) in Top Panel (28) and Top Crossbeam (15) and attach with a Phillips headscrewdriver.

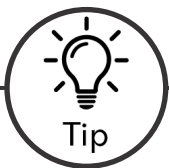
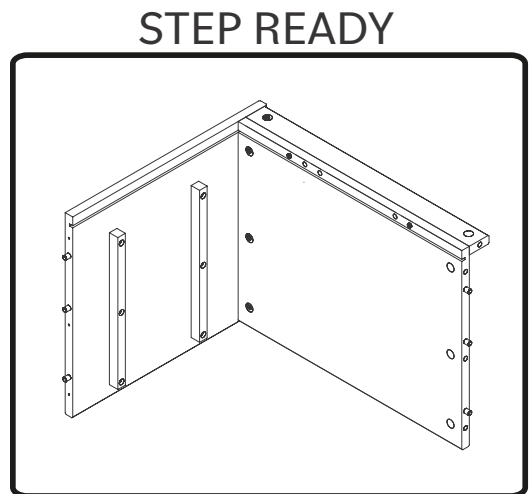
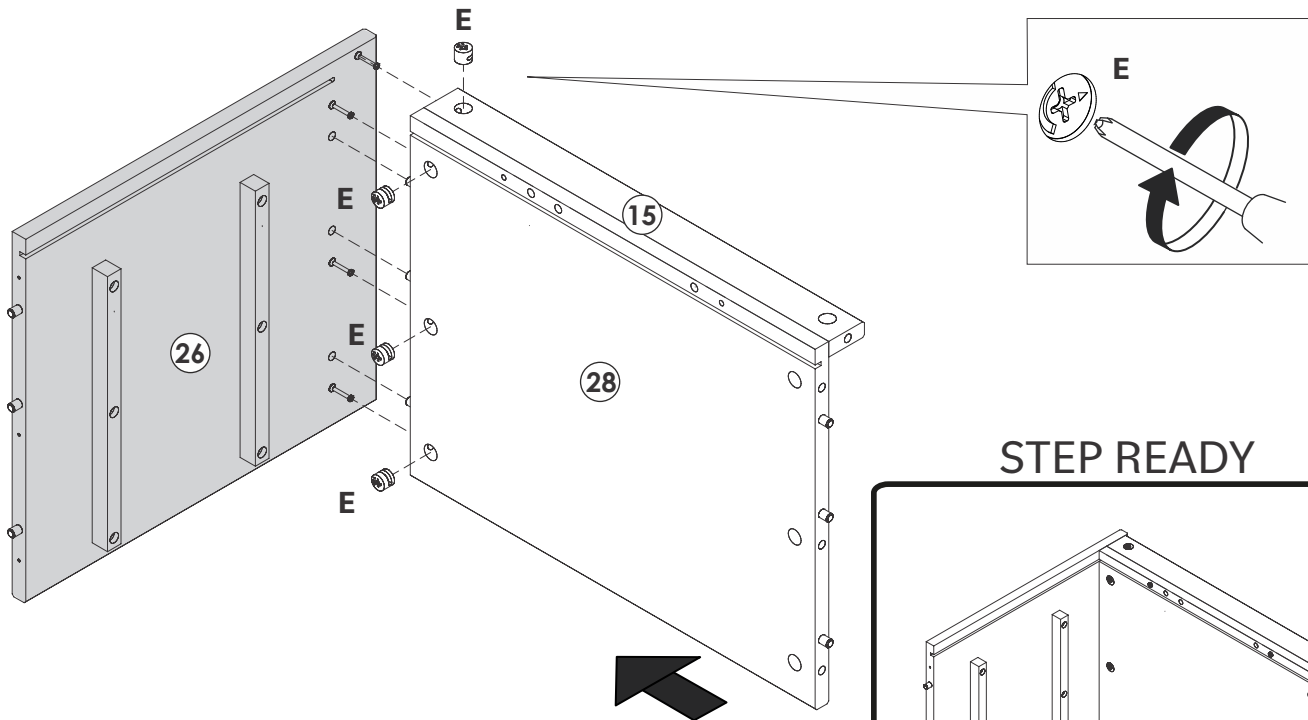
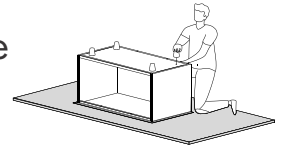

Tip

## Cam Locks

Cam Locks help securely join two pieces together. Follow these easy steps.

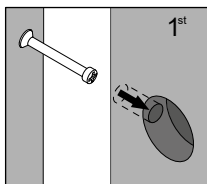

1: Insert Cam Bolt into bolt holes on the flat side. Don't over tighten!

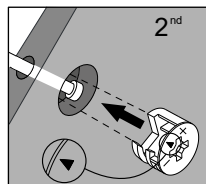

2: Assemble both parts together. The cam bolts goes in the drills holes that have a circular hole on the side, you should be able to see the cam bolt through it. After fitting parts together insert the cam lock on the side holes.

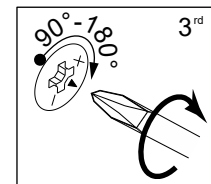

3: On the back of the Cam Lock will be a 'C' shape. Insert the Cam Lock so the opening of the 'C' fits over the Cam Bolt. Tighten with the screwdriver.

# Step 7

Attach Left Side Panel (24) to Top Panel (28) and Top Crossbeam (15) using Cam lock (E) and a Phillips head screwdriver.

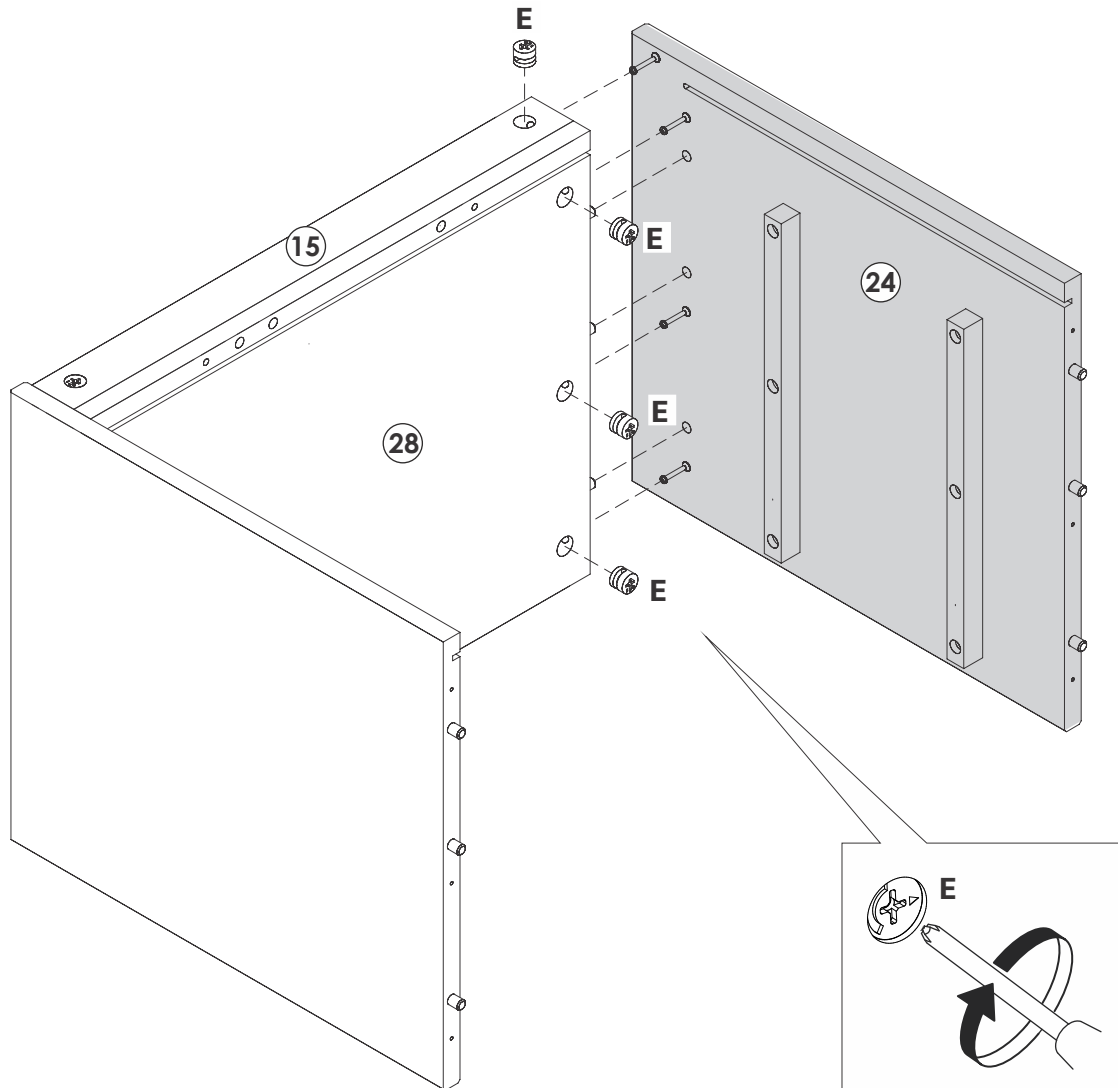
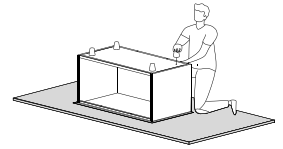

STEP READY

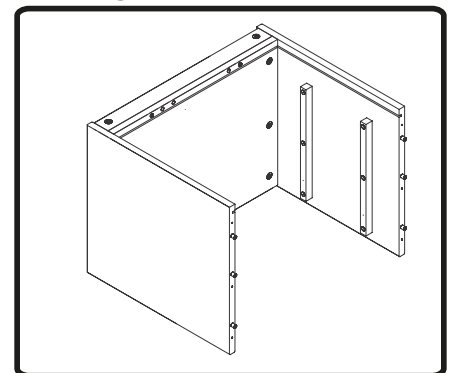

# Step 8

Insert Back Panel (30) into the grooves on Left Side Panel (24) and Right Side Panel (26) fitting in Top Panel (28).

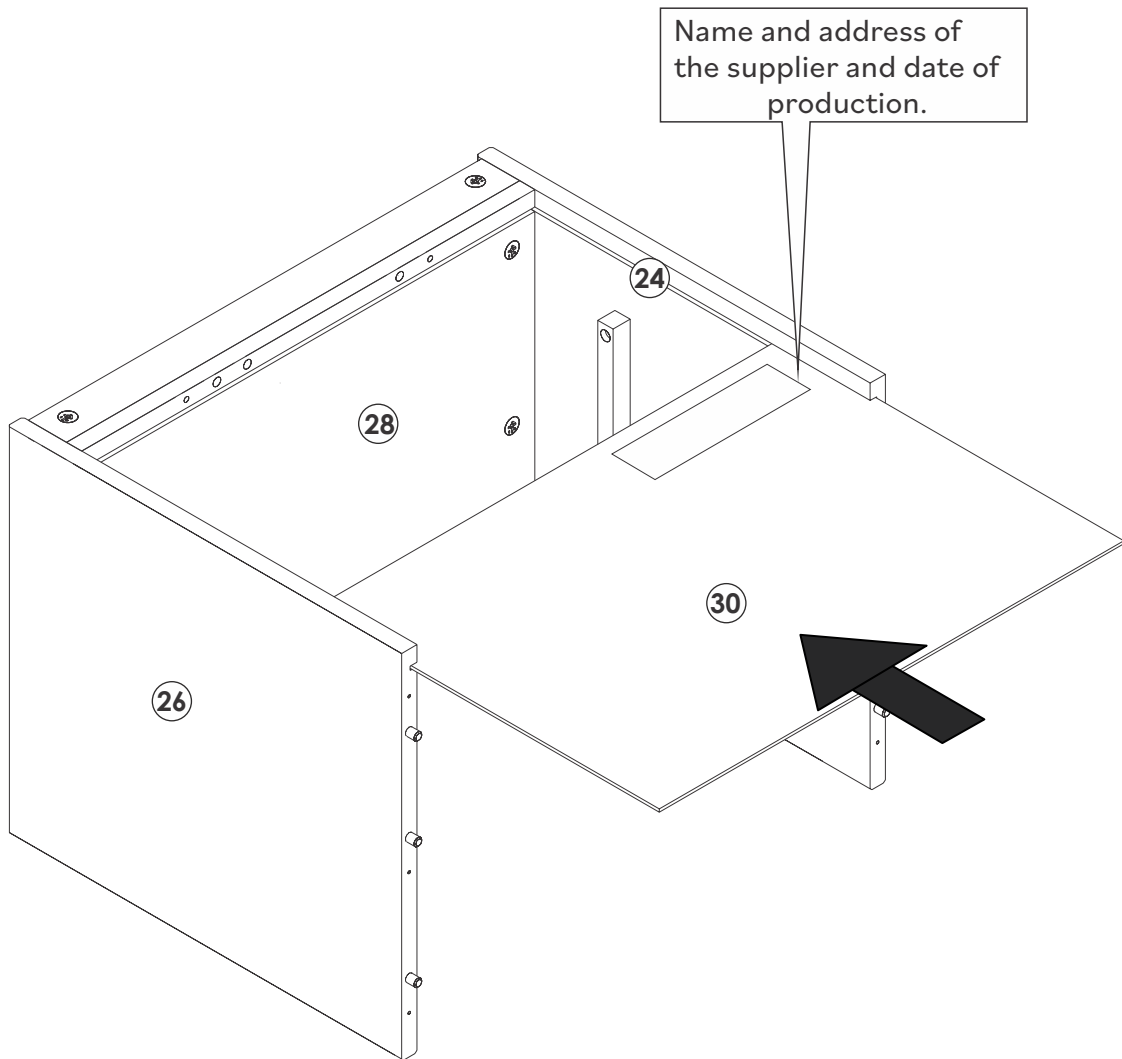
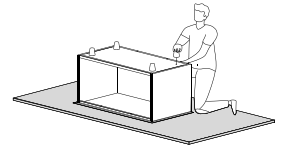

STEP READY

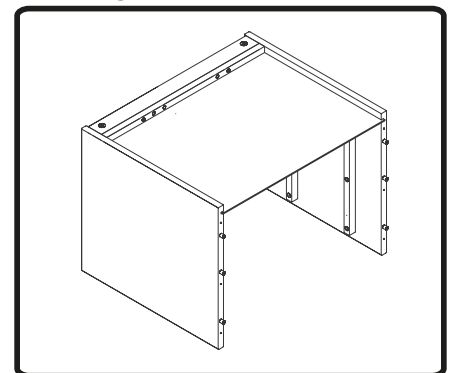

# Step 9

Secure Base Panel (32) to Left Side Panel (24) and Right Side Panel (26) with Screw (C) and a Phillips head screwdriver.

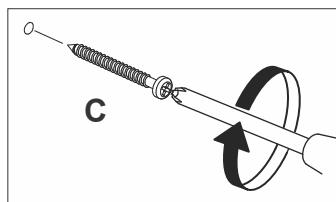
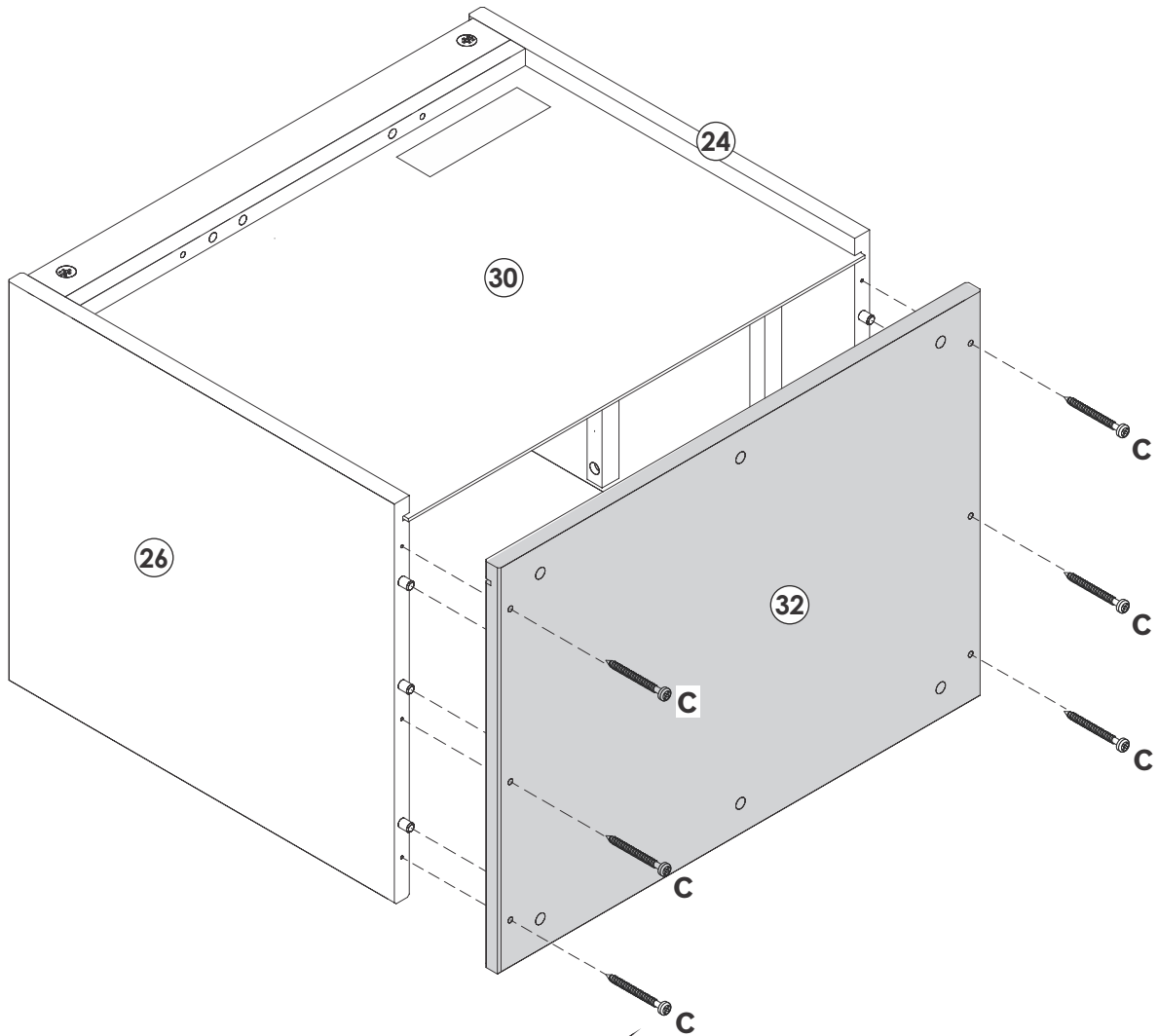
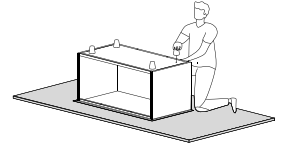

STEP READY

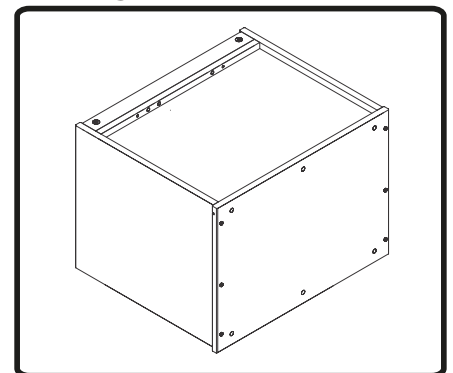

# Step 10

Secure Bottom Front Crossbeam (34) to Leg (36) with Screw (C) and a Phillips head screwdriver.

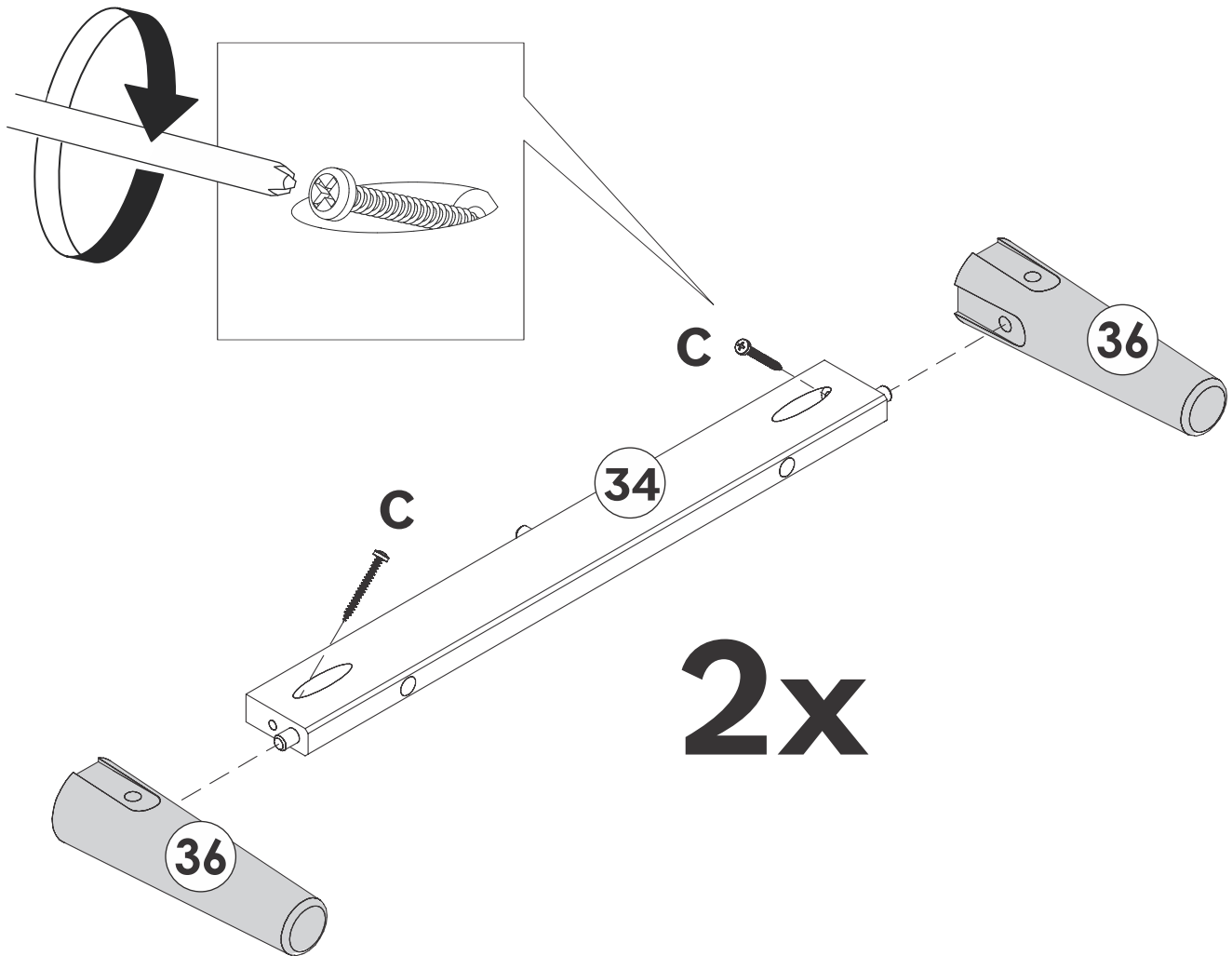
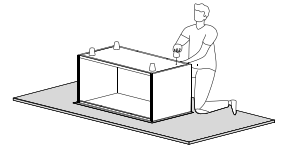

STEP READY

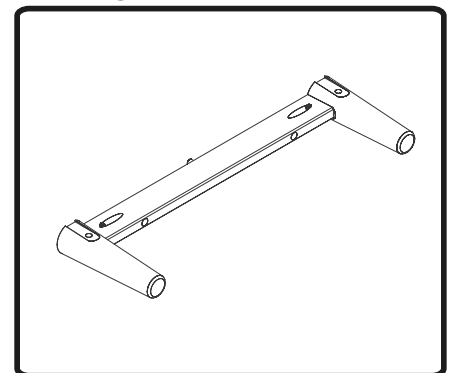

# Step 11

Secure Bottom Side Crossbeam (33) to Leg (36) with Screw (C) and a Phillips head screwdriver.

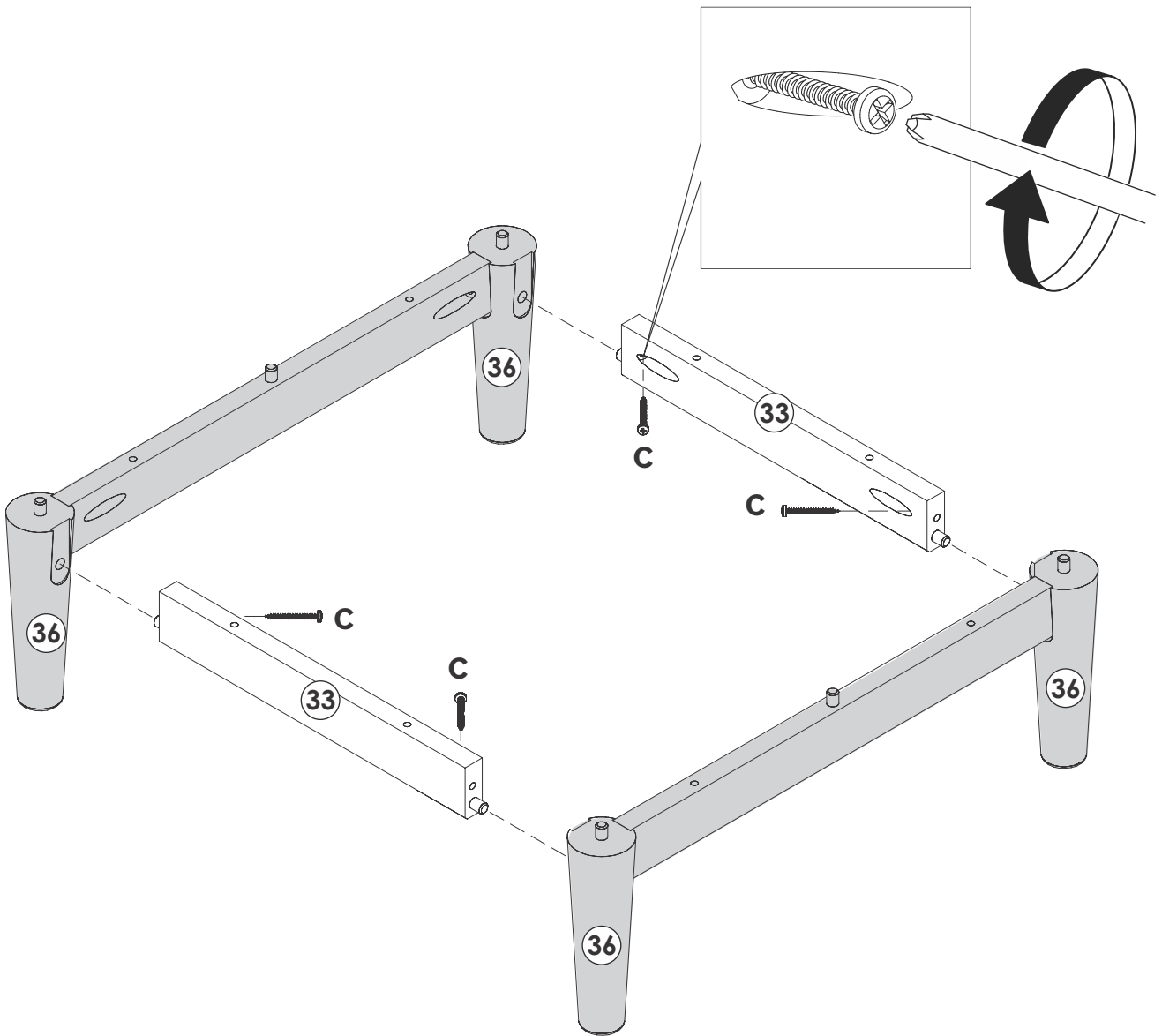
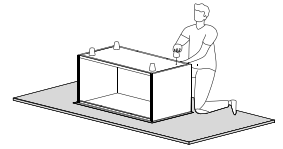

STEP READY

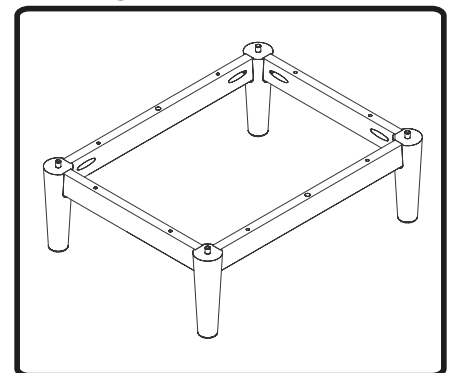

# Step 12

Secure the Bottom Side Crossbeam (33) and the Bottom Front Crossbeam (34) to Base Panel (32) with Screw (C) and a Phillips head screwdriver.

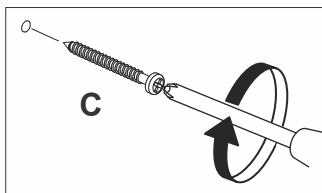
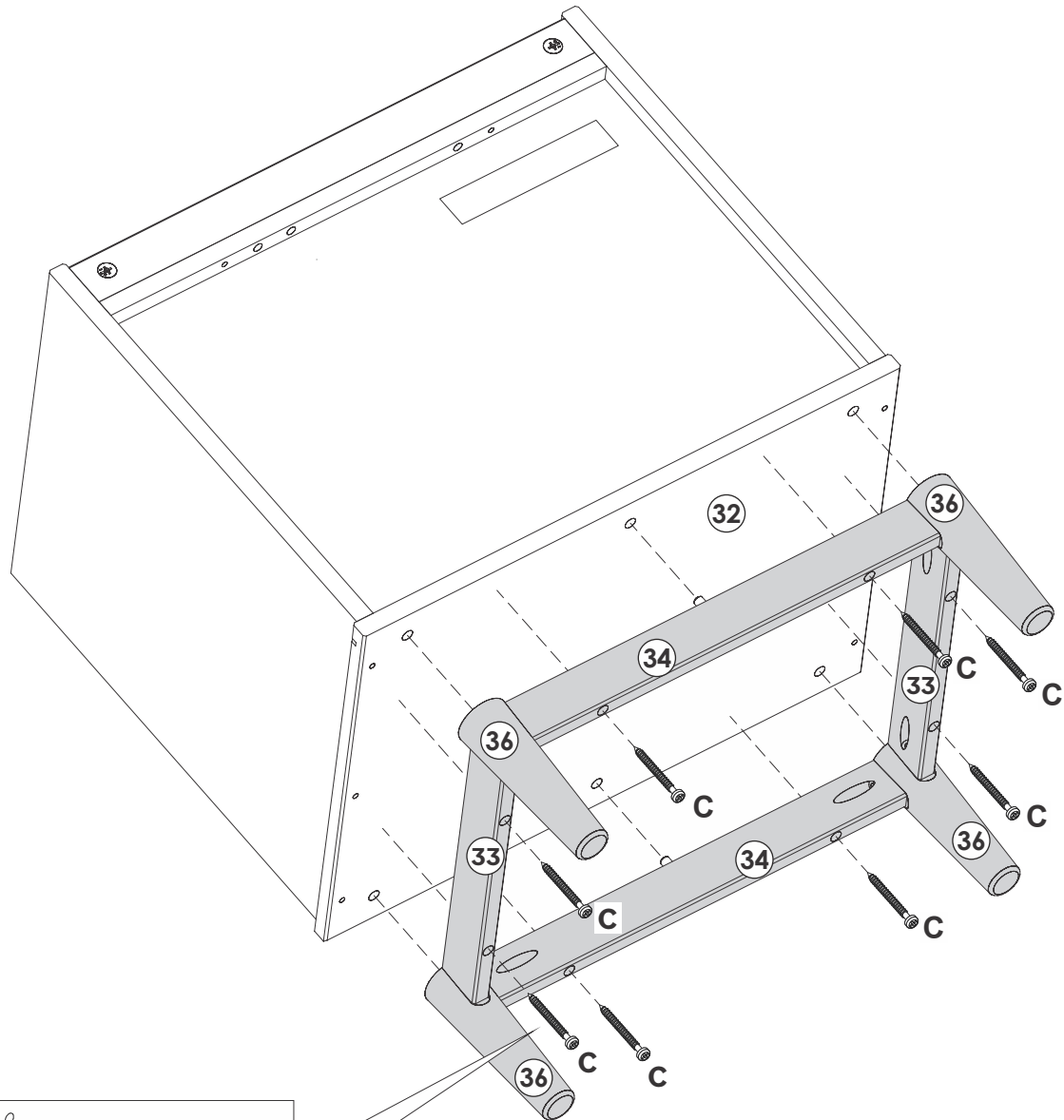
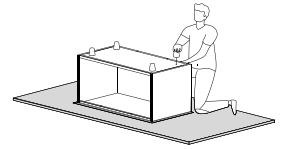

STEP READY

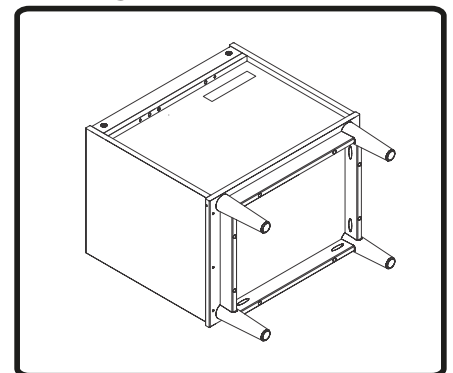



# Step 13

Insert Wooden Dowel (A) into the front hole in the Drawer Runner (17).

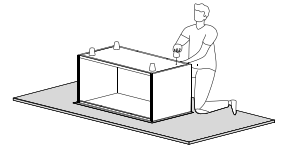

Rotate 90°

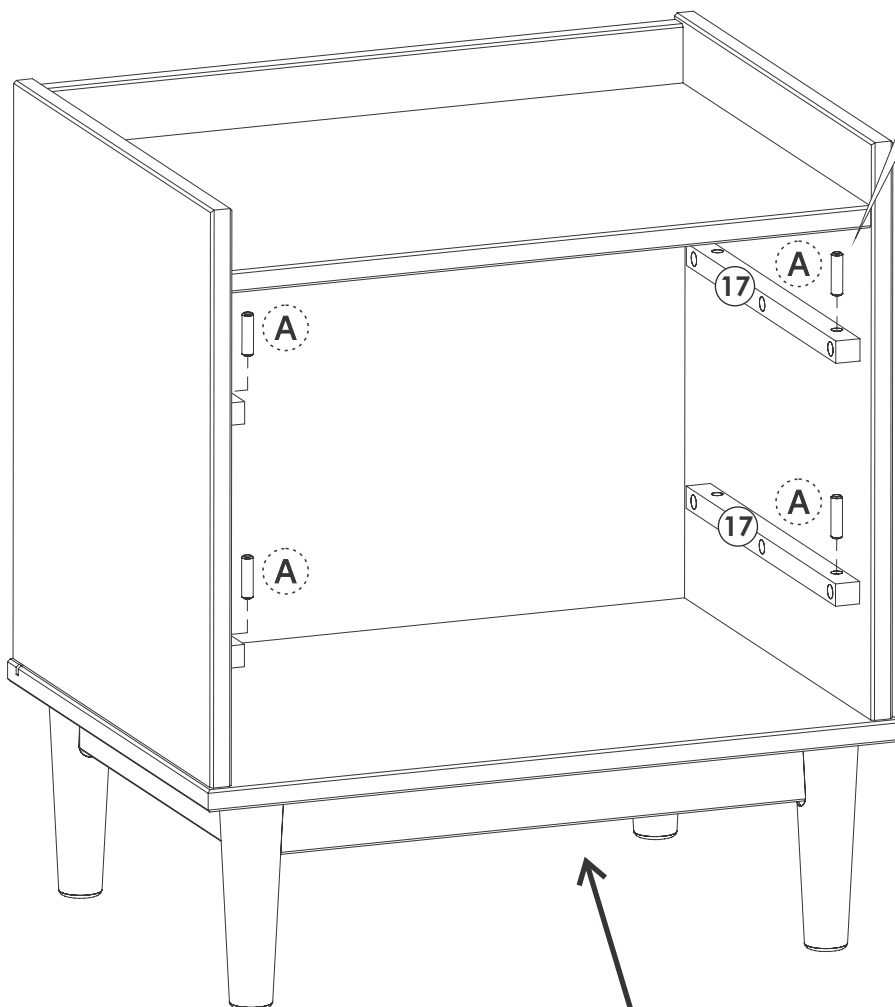
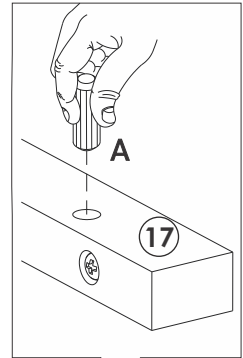
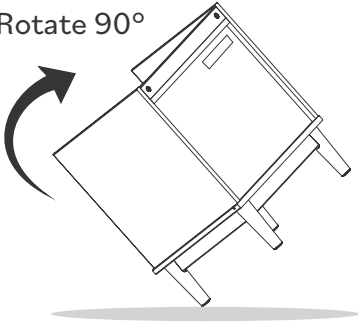

FRONT

# Step 14

Secure Drawer Left Side (46) and Drawer Right Side (47) to the Drawer Front (06) with Screw (G) and a Phillips head screwdriver.

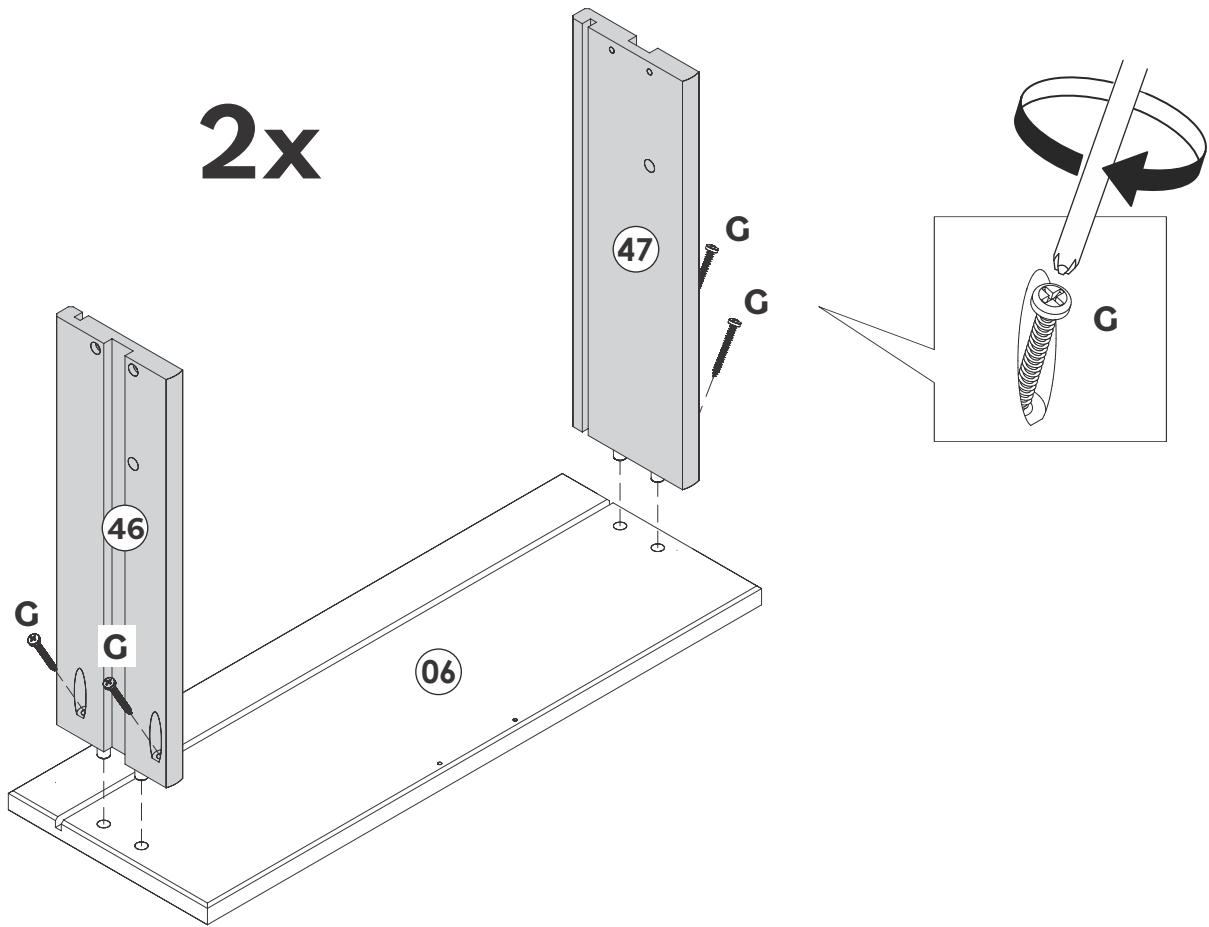
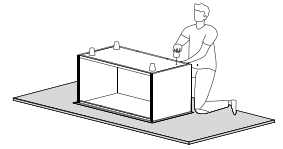

STEP READY

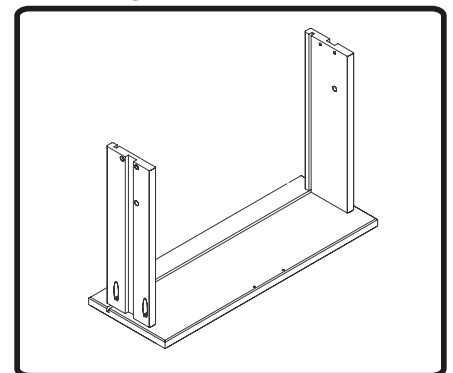

# Step 15

Slide Drawer Bottom (48) into the grooves on Left Drawer Side (46) and Right Drawer Side (47), and secure Drawer Back (45) with Screw (G) and a Phillips head screwdriver.

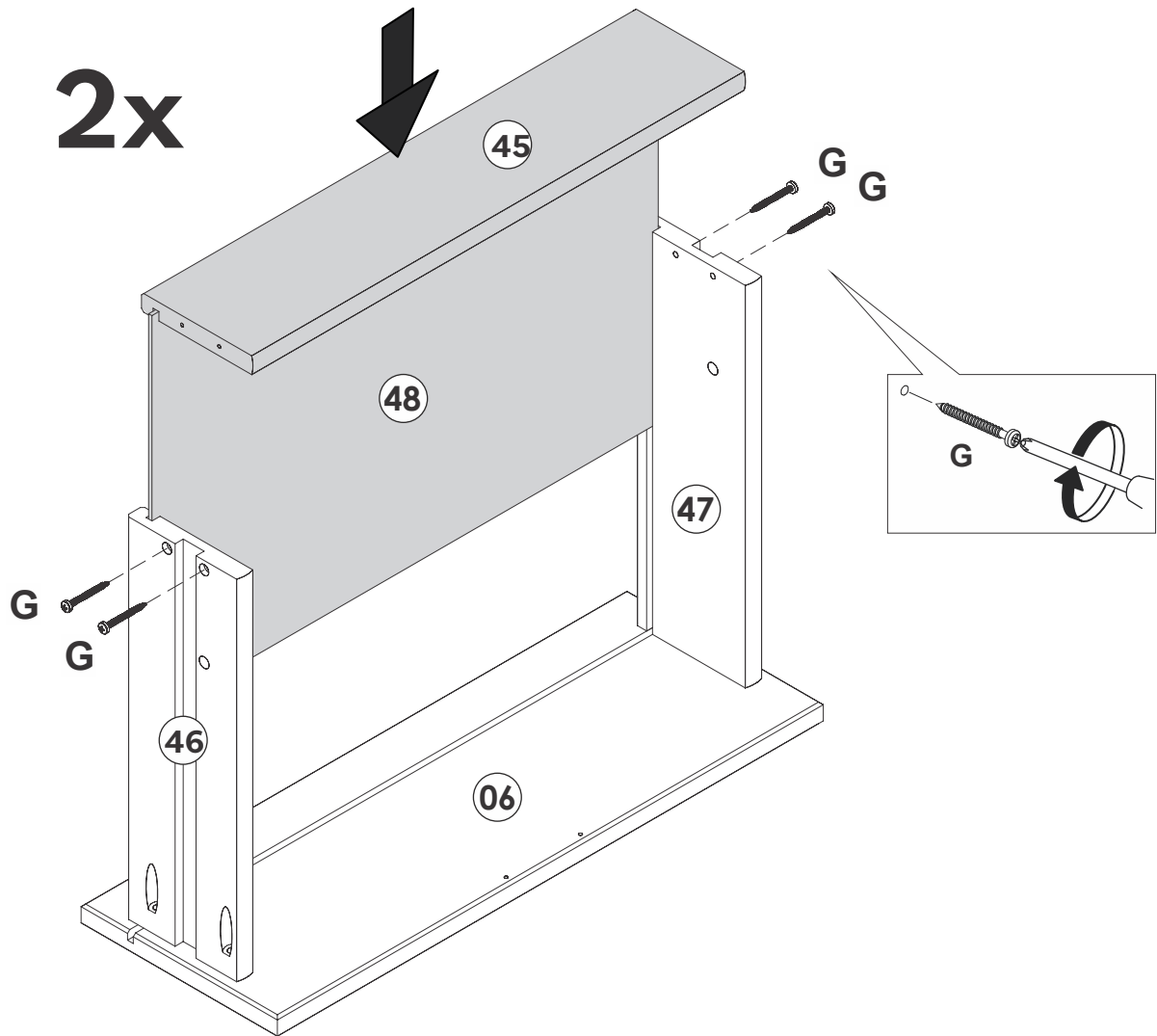
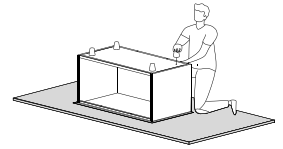

STEP READY

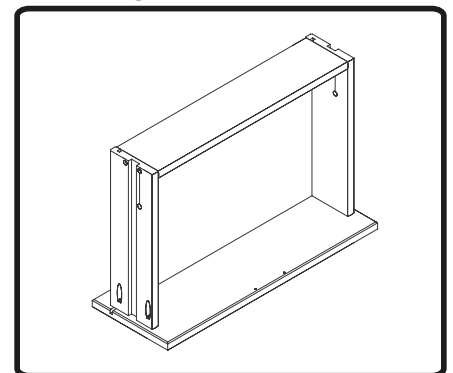

# Step 16

Attach Handle (J) with Screw (D) and a Phillips head screwdriver.

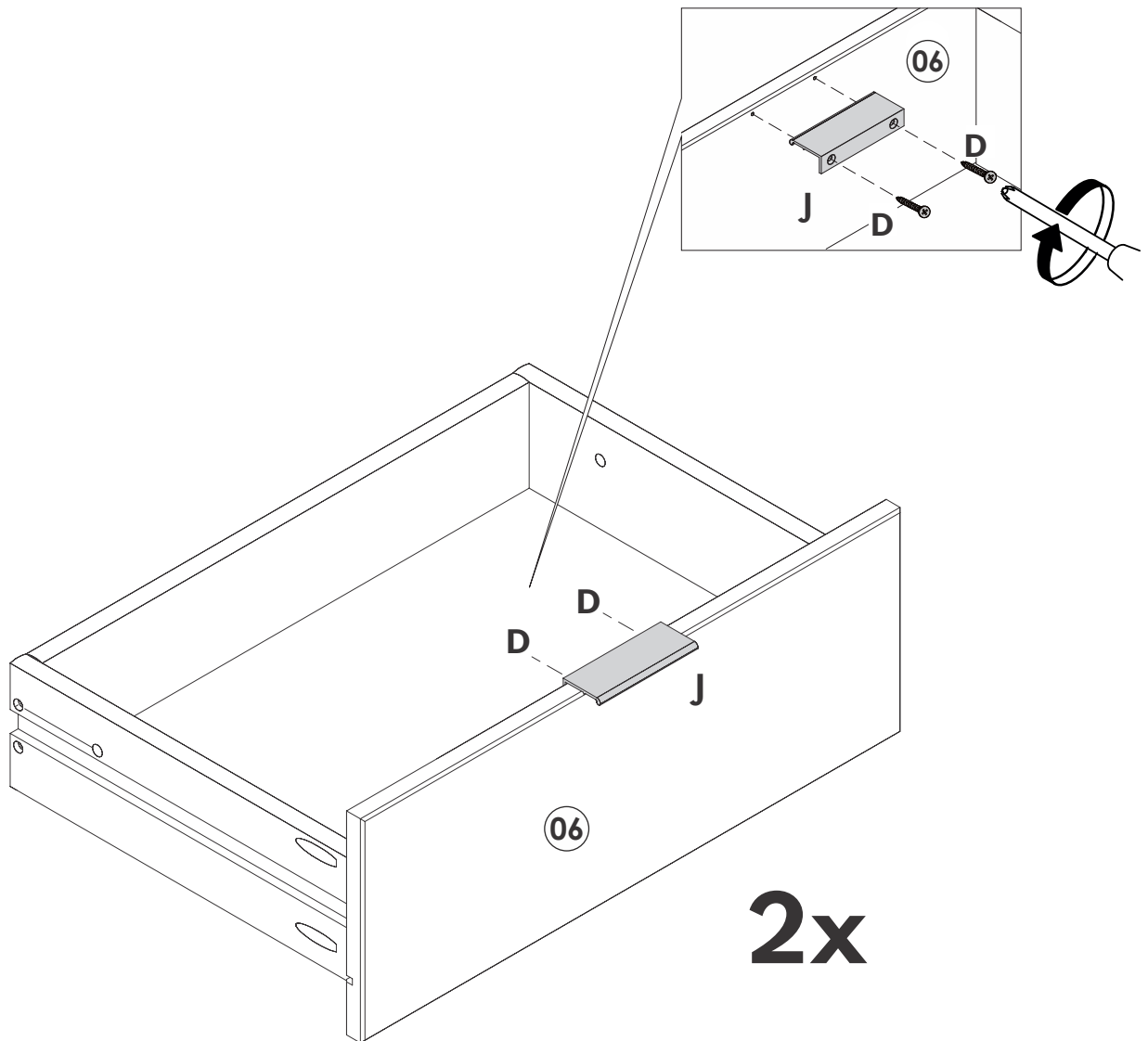
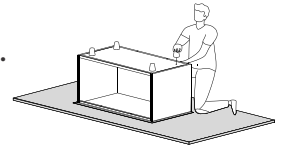

# Step 17

One at a time, place each drawer inside the unit, ensuring that you have passed the wooden dowel that is on the drawer slide. Then, insert Wooden Dowels (H) into place inside the drawers. Please note: Do not push the dowel all the way in. It will slightly stick out into the drawer so you are able to remove it if needed.

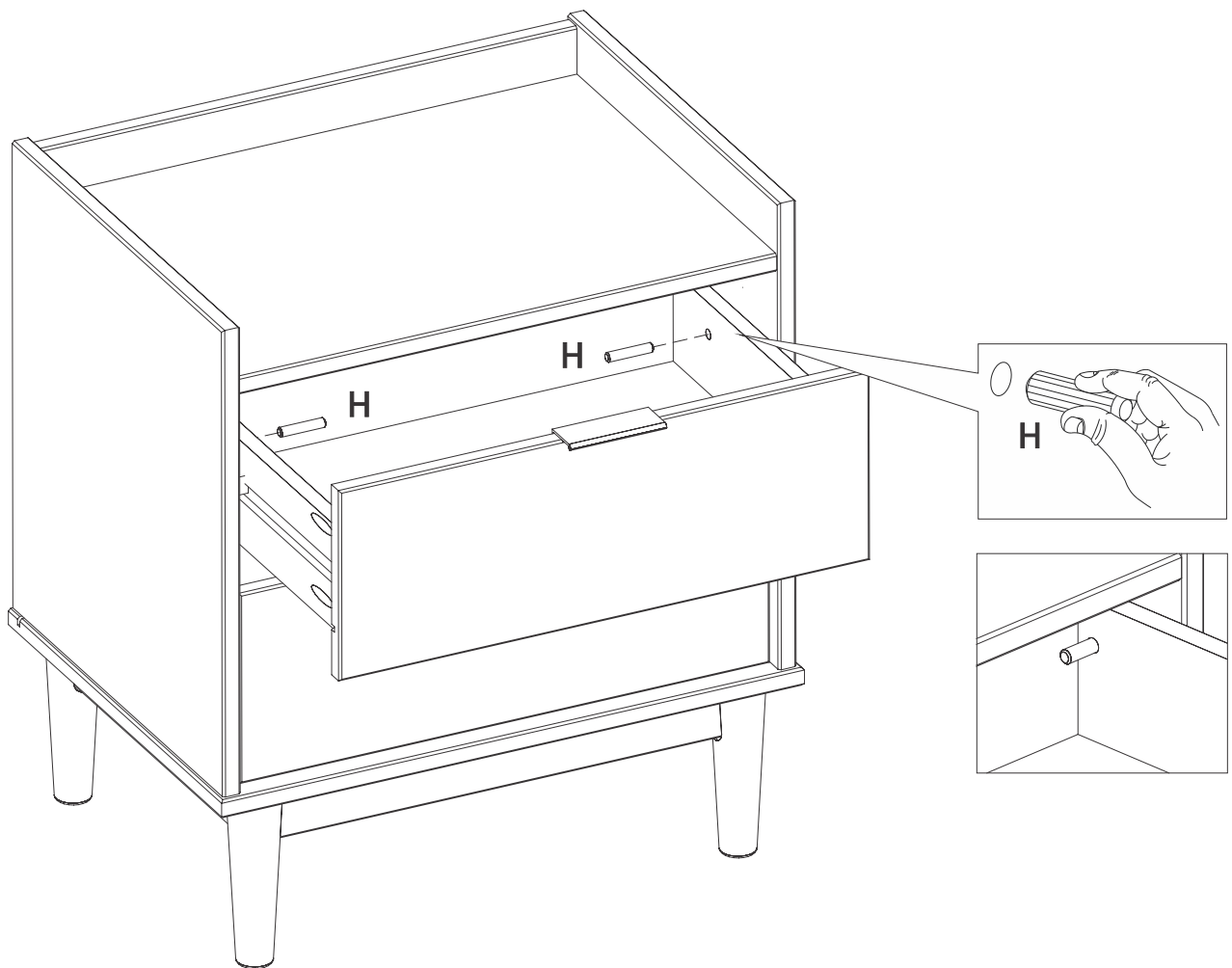
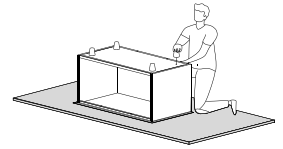

You did it! Enjoy your new nightstand!

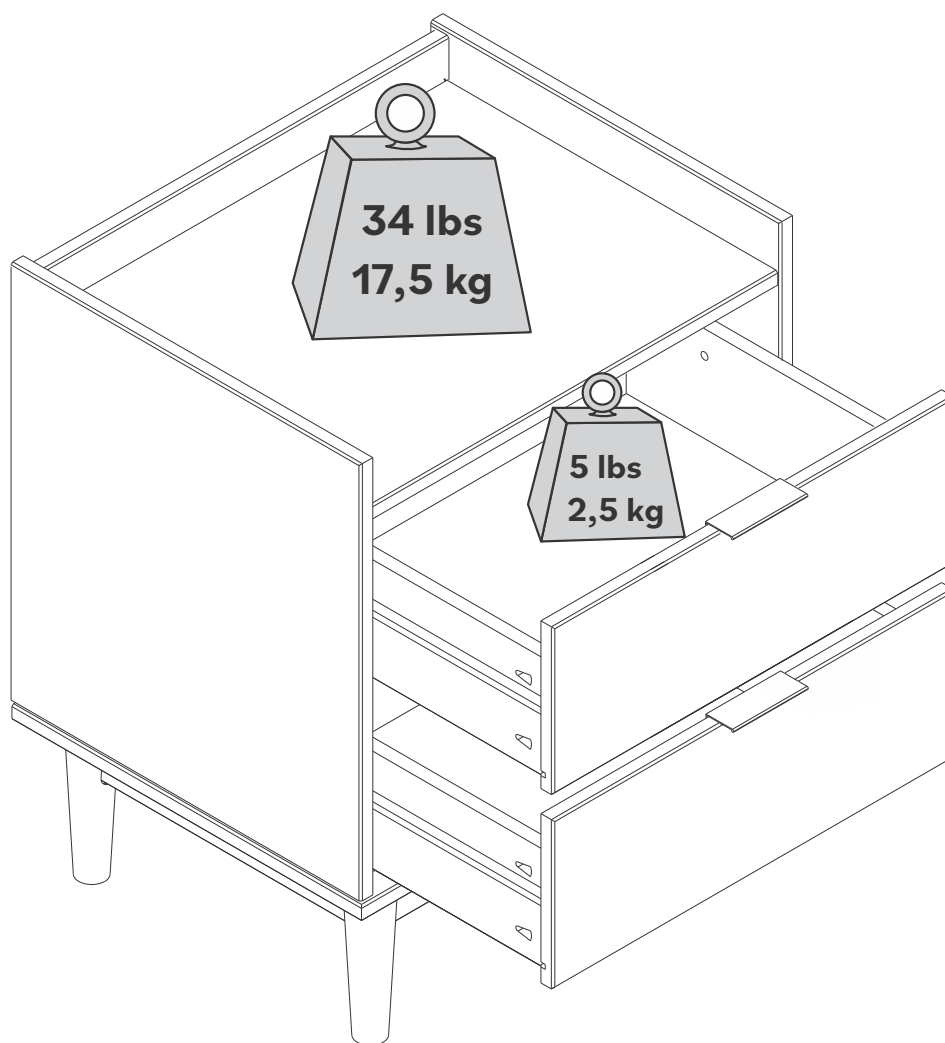

Congratulations on you new piece of furniture!  
We would love to hear about it and see it.  
Please leave us a review or post a picture with  
[#mywalkeredisonhome](#)

# Assembling furniture can be tricky sometimes.

Our customer service team, located in Utah, is here for product information, help assembling a product, or for any other customer support issue

Call us at **801-433-3008**

Email us at **[service@walkeredison.com](mailto:service@walkeredison.com)**

Visit our Customer Service website at **[walkeredison.com/pages/customer-service](http://walkeredison.com/pages/customer-service)**

We are available to help Monday-Thursday 8am-5pm, Friday 8am-3pm MST

For details on Assembly Videos, Assembly Instructions, Replacement Parts, and Customer service,

**SCAN HERE**

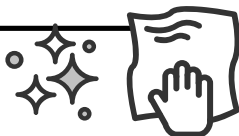

For cleaning, never use abrasives, use a soft cloth and water with neutral soap to clean the furniture.

# WALKER EDISON™

## Lee Table de Chevet avec 2 Tiroir Lee Mesita de Noche con 2 Cajónes

SKU: LEEB4C  
LOT: **AAYYWW-XXX**

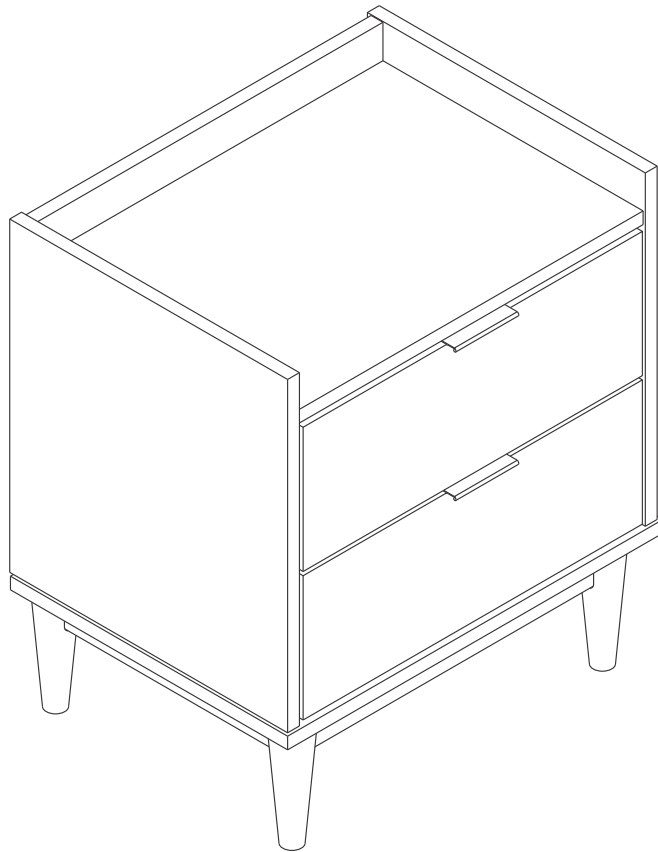

### *Pour usage résidentiel seulement*

Visite notre site Web pour obtenir les instructions les plus récentes, des conseils d'assemblage, signaler des dommages ou commander des pièces. [www.walkeredison.com](http://www.walkeredison.com)

### *Sólo para uso residencial*

Visite nuestro sitio web para consultar las últimas instrucciones, consejos de montaje, notificar daños o solicitar piezas. [www.walkeredison.com](http://www.walkeredison.com)



# WE Il est temps de commencer / Hora de empezar

Prépare un lieu de travail propre et souple pour éviter tout dommage lors de l'assemblage. Tu peux utiliser la boîte et les protections internes comme base. Vérifie également que tu disposes de toutes les pièces et parties avant de te lancer dans l'assemblage.

Prepare un lugar de trabajo limpio y blando para evitar daños durante el montaje. Puede utilizar la caja y las protecciones internas como base. Comprueba también que tiene todas las piezas y partes antes de sumergirse en el montaje.

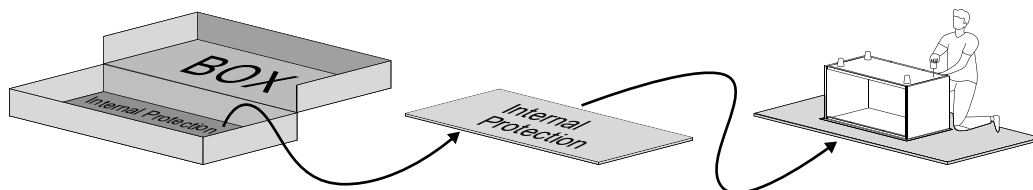

**Temps de montage  
estimé**

**Tiempo estimado  
de montaje**

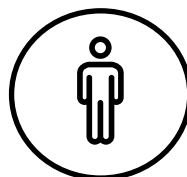

1 Person Build

**Vous pouvez le faire seul.**

Mais vous pouvez en faire un travail d'équipe !  
Demandez à un ami de vous aider à l'assembler plus rapidement et plus facilement.

**Puedes hacerlo solo**

Pero también puedes hacerlo en equipo.  
Llévate a un amigo para que el montaje sea más rápido y sencillo.

## Outils nécessaires

Munis-toi d'un tournevis cruciforme pour réaliser cet assemblage

## Herramientas requeridas

Tome un destornillador Phillips para conquistar este conjunto.

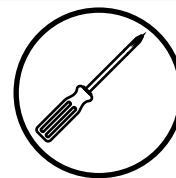

## Utilise les outils électriques avec précaution

Ce meuble est réalisé en Bois Massif et Bois Composite, des matériaux souples. Si tu choisis d'utiliser des outils électriques, règle-les sur le mode le plus lent. Fais attention à toi ! Les outils électriques peuvent provoquer des fissures ou endommager les meubles, mais aussi les autres composants s'ils sont mal utilisés. Les dommages causés par un outil électrique ne sont pas couverts par la garantie Walker Edison.

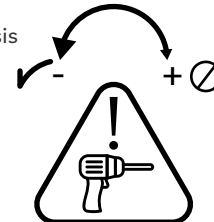

## Utilice las herramientas eléctricas con cuidado

Este mueble está fabricado con madera maciza y madera compuesta, materiales blandos. Si decide utilizar herramientas eléctricas, ajústelas al ajuste más lento. Tenga cuidado. Las herramientas eléctricas pueden causar grietas o daños en el mueble, pero también en los herrajes si se utilizan mal. Los daños causados por una herramienta eléctrica no están cubiertos por la garantía de Walker Edison.

## Attention avec la glissière

Tes meubles possèdent des glissières en bois très résistantes. De temps en temps, nous recommandons d'appliquer de la paraffine ou de la cire de bougie standard pour améliorer la glisse des curseurs.

## Cuidado con las guías

Tus muebles cuentan con guías de madera de alta durabilidad. De vez en cuando, recomendamos la aplicación de parafina o cera estándar para mejorar el deslizamiento de los deslizadores.



**Scannez pour obtenir des conseils d'assemblage et de l'aide !**  
**Escanee para obtener consejos de montaje y ayuda!**







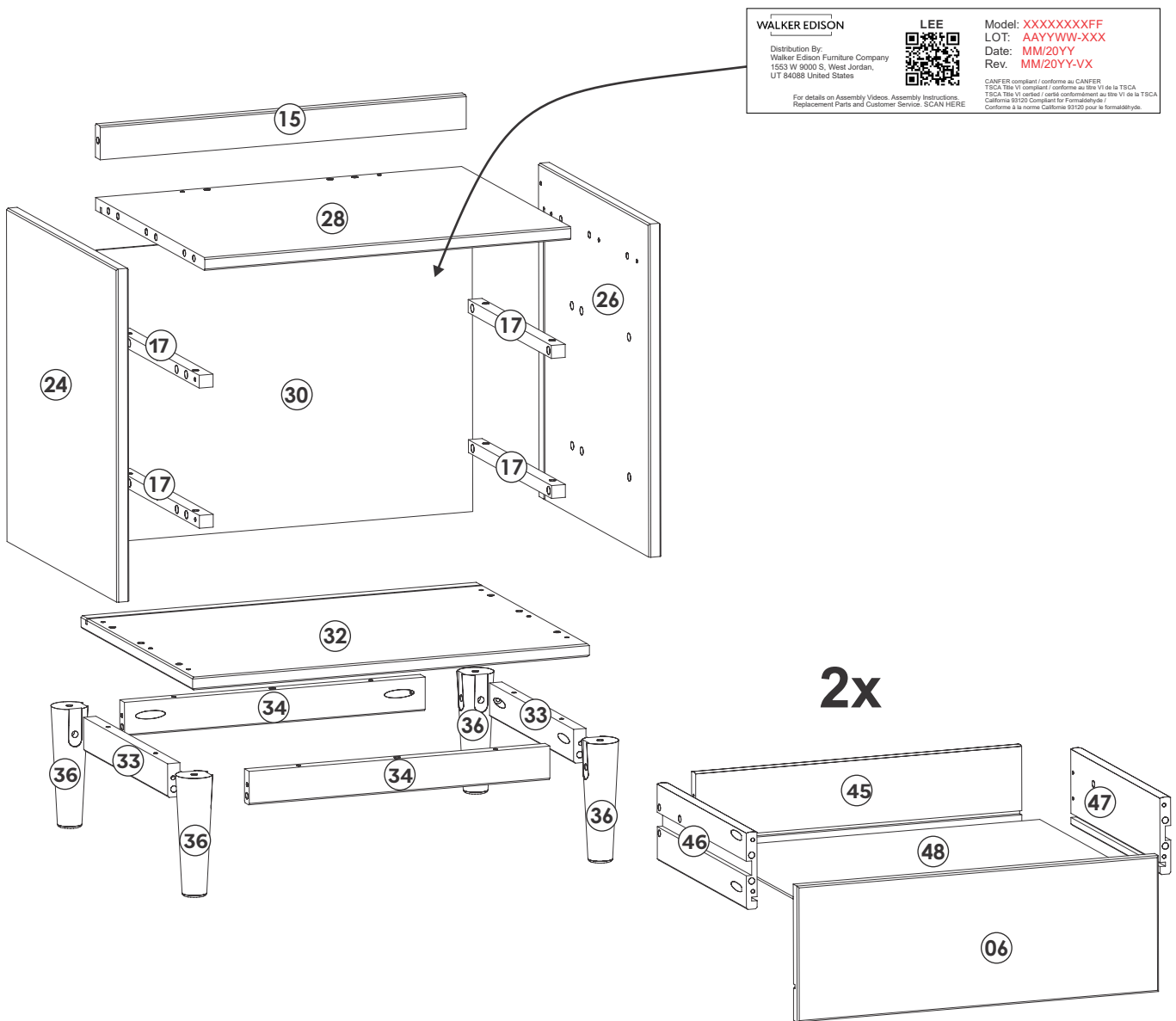

# WE Liste de pièces / Lista de piezas

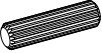
Nombre de pièces Número de pieza	Description Descripción	Quantité Cantidad
06	Façade du Tiroir Frente del Cajón	02
15	Traverse Supérieur Travesaño Superior	01
17	Glissière Corredera	04
24	Panneau Gauche Panel Izquierdo	04
26	Panneau Droit Panel Derecho	01
28	Panneau Supérieur Panel Superior	01
30	Panneau Arrière Panel Trasero	01
32	Panneau Inférieur Panel Inferior	01

Nombre de pièces Número de pieza	Description Descripción	Quantité Cantidad
33	Traverse Inférieur Travesaño Inferior	02
34	Traverse inférieure avant Travesaño Delantero Inferior	02
36	Pied Pie	04
45	Arrière du Tiroir Trasero del Cajón	02
46	Côté Gauche du Tiroir Lado Izquierdo del Cajón	02
47	Côté Droit du Tiroir Lado Derecho del Cajón	02
48	Fond du Tiroir Inferior del Cajón	02

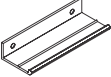

## WE Liste de composants / Lista de hardware

	Partie Parte	Taille Tamaño	Nom Nombre	Quantité Cantidad
A		8x30mm	Cheville Espiga	41
B		10x20mm	Cheville Espiga	12
C		4,0x40mm	Vis Tornillo	22
D		3,0x12mm	Vis Tornillo	04
E		15x12mm	Boitier Traba	08
F		5x24mm	Goujoun Conector	08
G		3,5x30mm	Vis Tornillo	18
H		8x40mm	Cheville Espiga	04
I		4,0x25mm	Vis Tornillo	12
J			Poignée Manija	02

Les quantités de composants indiquées ci-dessus sont nécessaires pour un assemblage correct.  
Des pièces supplémentaires peuvent être incluses.

Las cantidades de tornillería indicadas anteriormente son necesarias para un montaje correcto.  
Se pueden incluir piezas de ferretería adicionales.

# Étape / Paso 1

(FR)  
 Insérez la Cheville (B) dans la Glissière (17)  
 (ESP)  
 Inserte la espiga (B) en la Corredera (17)

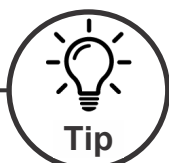
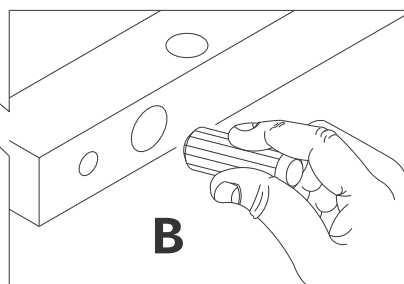
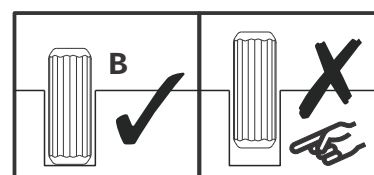
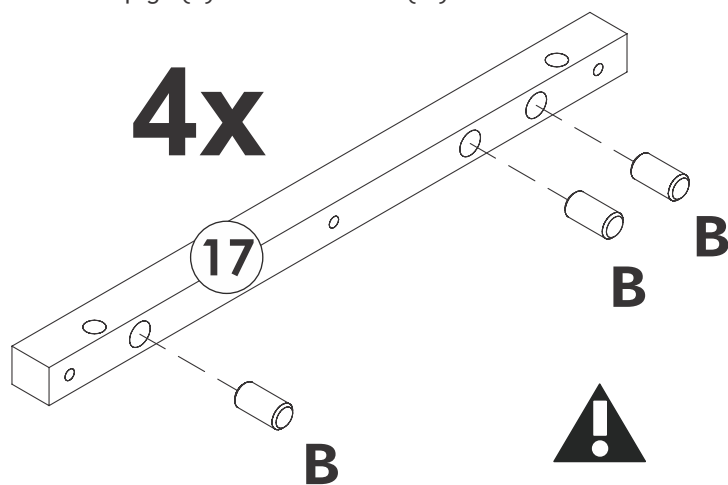
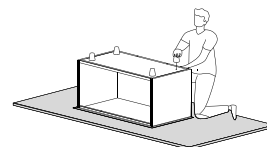

Les chevilles sont essentielles lors de l'assemblage de meubles pour créer des connexions solides et précises. Elles garantissent l'intégrité structurelle, empêchent les déplacements et simplifient l'alignement, ce qui permet d'obtenir des meubles plus résistants et plus durables. Suis ces étapes:

Las espigas son esenciales en el montaje de muebles para crear uniones fuertes y precisas. Garantizan la integridad estructural, evitan el desplazamiento y simplifican la alineación, lo que se traduce en muebles más resistentes y duraderos. Sigue estos pasos:

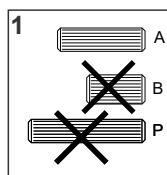

1: Sélectionne la taille de cheville appropriée en fonction de l'étape.  
 1: Seleccione el tamaño de espiga adecuado según el paso.

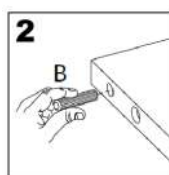

2: Insère dans le trou indiqué et appuie fermement pour assurer un positionnement correct.  
 2: Insértela en el orificio indicado y presione firmemente para asegurar su correcta colocación.

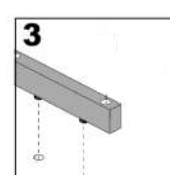
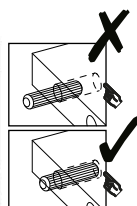

3: Aligne la cheville avec la pièce correspondante et enfonce-la jusqu'à ce qu'elle soit ferme.  
 3: Alinee el pasador con la pieza correspondiente y presiónelo hasta que encaje

# Étape / Paso 2

(FR)

Insérez le Cheville (A) dans la Traverse supérieure (15), Panneau gauche (24), Panneau droit (26), la Traverse inférieure (33), Traverse avant inférieure (34), Côté gauche du tiroir (46) et le Côté droit du tiroir (47).

(ESP)

Inserte la Espiga (A) en el Travesaño superior (15), Panel izquierdo (24), Panel derecho (26), Travesaño inferior (33), Travesaño frontal inferior (34), Lado izquierdo del cajón (46) y Lado derecho del cajón (47).

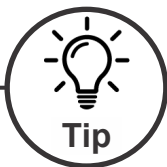
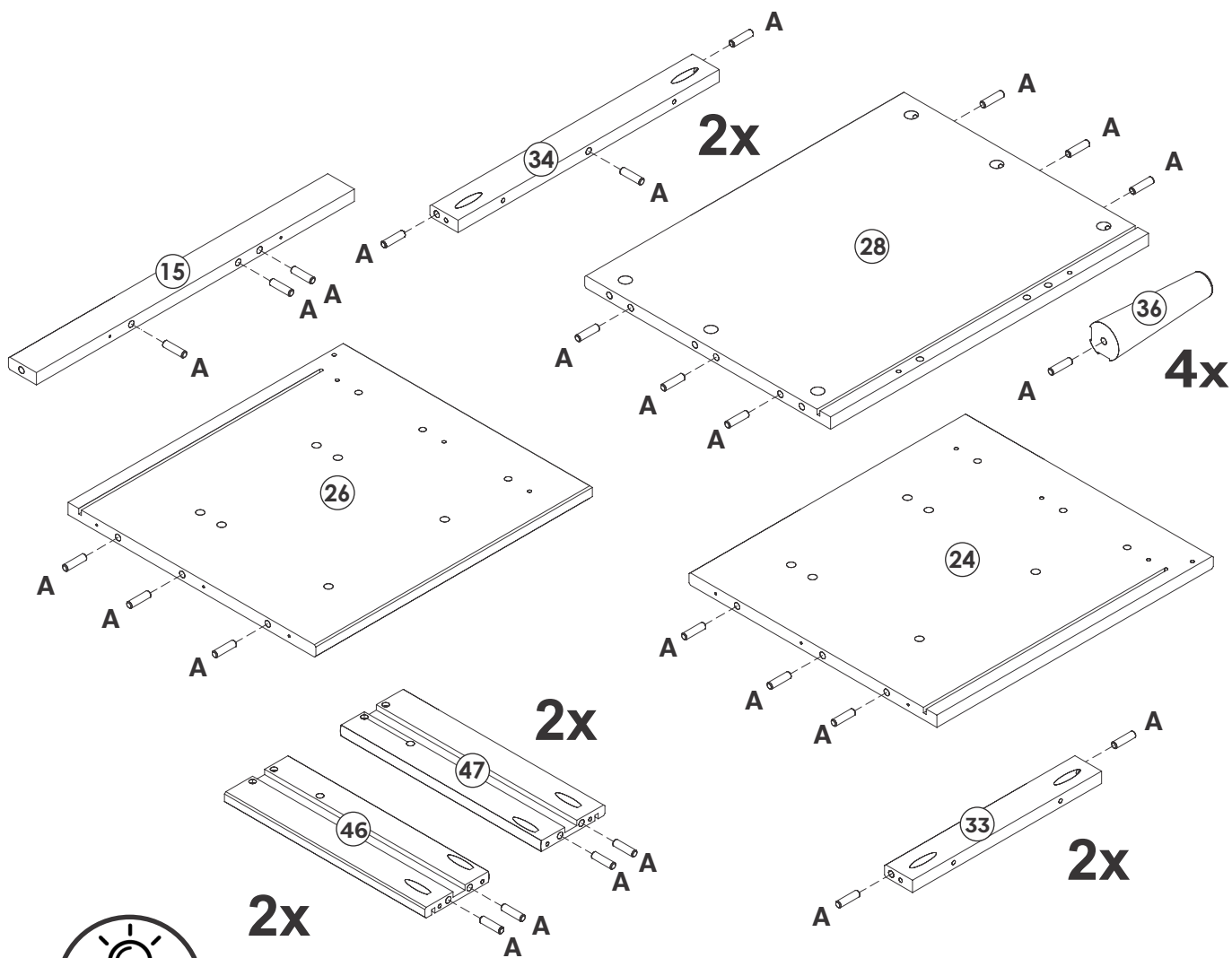

Pour que ton produit conserve son meilleur aspect et sans rayures, essaie de le monter sur une surface souple telle qu'un tapis ou une couverture. Cela permet d'éviter les rayures accidentelles et de garder tes meubles en bon état!

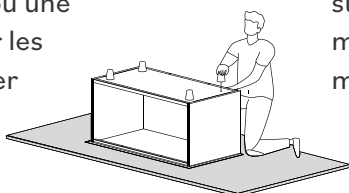

Para mantener su producto con el mejor aspecto y sin arañazos, pruebe a montarlo sobre una superficie blanda, como una alfombra o una manta. Así evitará arañazos accidentales y mantendrá sus muebles en perfecto estado.

# Étape / Paso 3

(FR)

Fixez la Vis (F) dans le trou du Panneau gauche (24) et du Panneau droit (26) avec un tournevis cruciforme.

(ESP)

Fije el Tornillo (F) en el orificio del Panel Izquierdo (24) y del Panel Derecho (26) con un destornillador Phillips

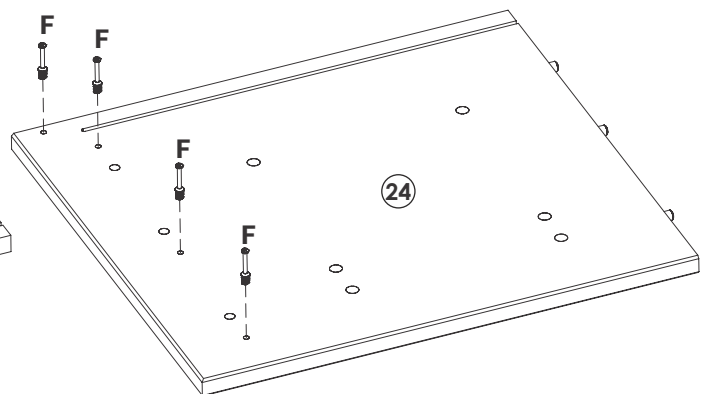
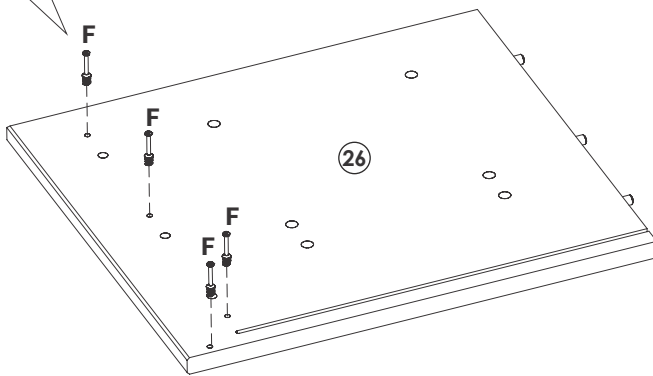
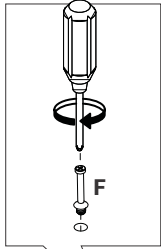
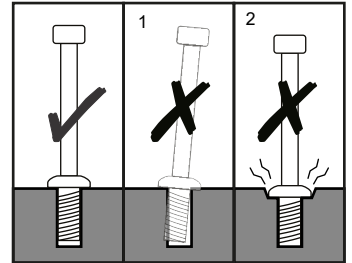
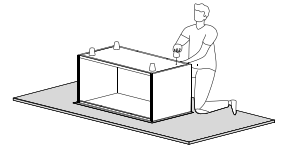

# Étape / Paso 4

(FR)

Fixez la Glissière (17) sur le Panneau gauche (24) et le Panneau droit (26) avec la Vis (I) et un tournevis cruciforme.

(ESP)

Fije la Corredera (17) al Panel izquierdo (24) y al Panel derecho (26) con el Tornillo (I) y un destornillador Phillips.

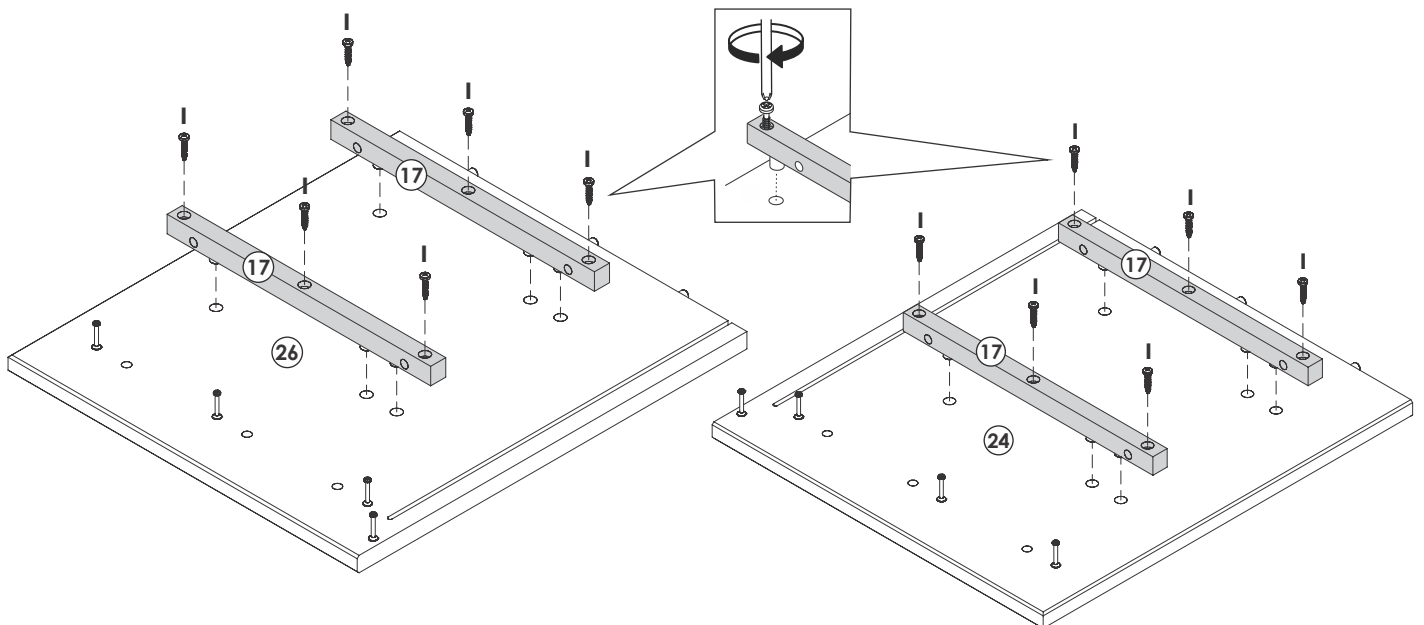

# Étape / Paso 5

(FR)

Fixez le Panneau Supérieur (28) à la Traverse supérieure (15) avec la Vis (G) et un tournevis cruciforme.

(ESP)

Asegure el Panel superior (28) a la Travesaño superior (15) con el Tornillo (G) y un destornillador Phillips.

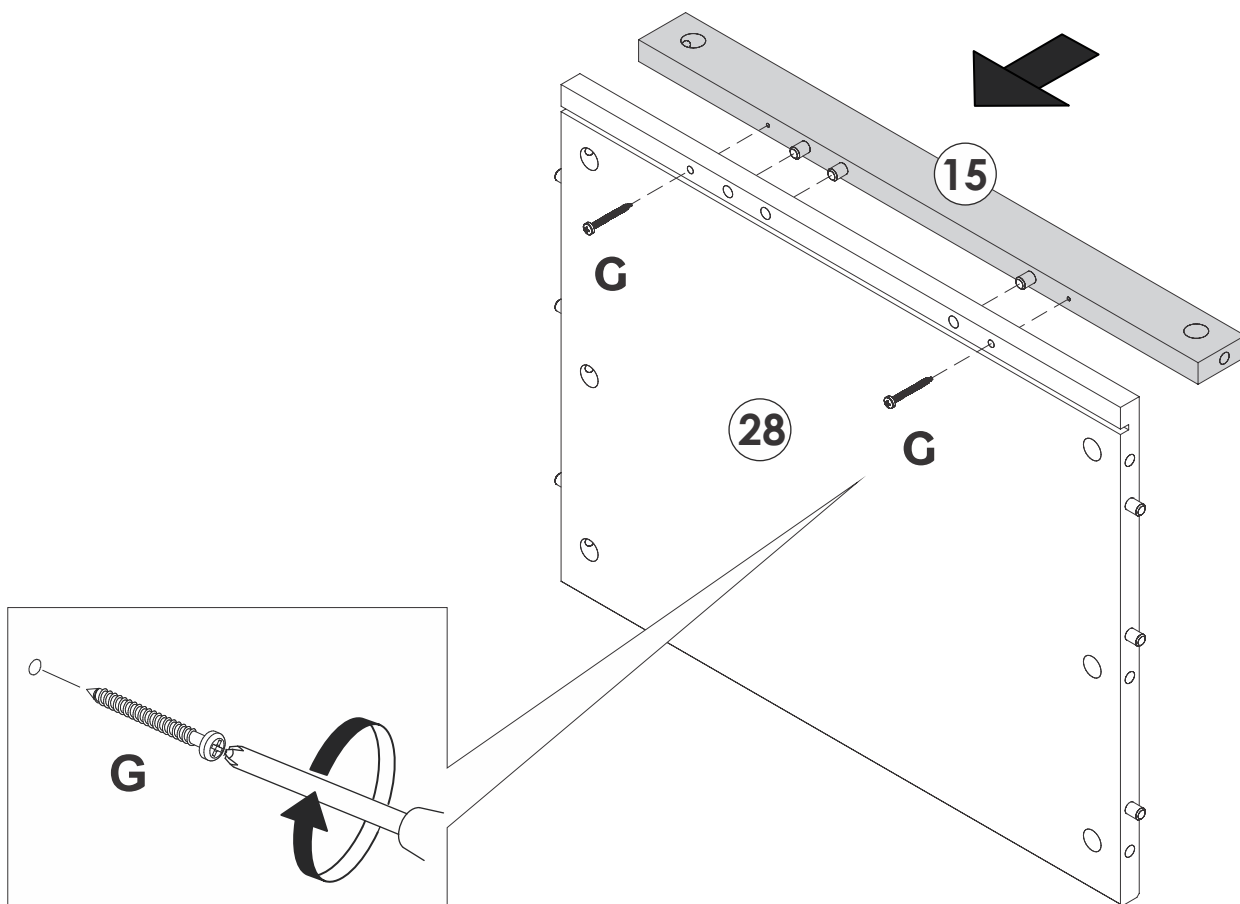
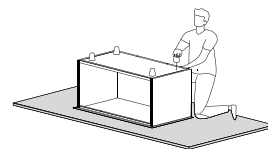

Étape Prête  
Paso Listo

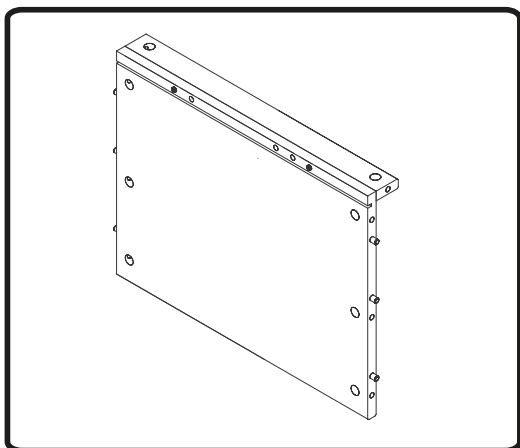

# Étape / Paso 6

(FR)

Montez le Panel supérieur (28) et la Traverse supérieure (15) sur le Panneau droit (26). Insérez le Boitier (E) dans le trou du Panneau supérieur (28) et Traverse supérieure (15) et fixez-les avec une tournevis cruciforme.

(ESP)

Coloque el Panel superior (28) y el Travesaño superior (15) en el Panel Derecho (26). Inserte la Traba (E) en el orificio del Panel superior (28) y Travesaño superior (15) y asegúrela con un destornillador Phillips.

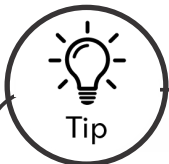
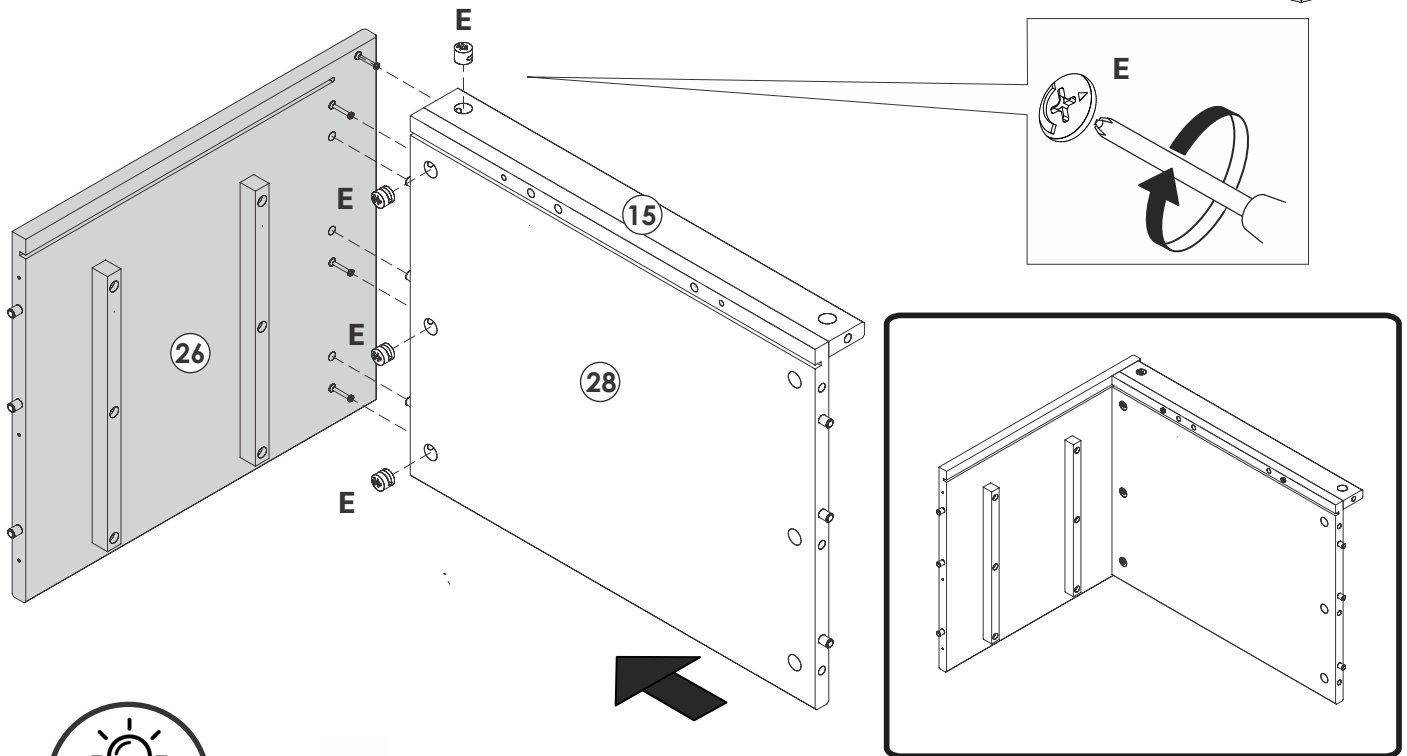

Tip

## Goujon de Assemblage

Goujon de Assemblage permet de joindre deux pièces en toute sécurité. Suis ces étapes simples.

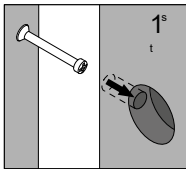

1: Insère le Goujon dans les orifices du côté plat. Ne serre pas trop!

1: Coloca el Conector en los orificios del lado plano. ¡No aprietes demasiado!

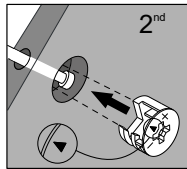

2: Joins les pièces en bois. Les Goujons entrent dans les orifices qui ont des trous sur les côtés, tu dois pouvoir voir les Goujons à travers ceux-ci. Après avoir installé les pièces, insère le Boitiers dans les orifices latéraux

2: Una las piezas de madera. Los Conectores entran en las piezas que tienen orificios en los lados, por lo que deberías poder ver los Conectores a través de ellos. Después de encajar las piezas, inserta la traba en los orificios laterales.

## Conector

Los Conector ayudan a unir de forma segura dos piezas. Sigue estas fáciles etapas.

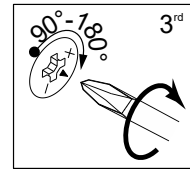

3: Sur la partie arrière du boitier, il aura la forme d'un « C ». Insère le boitier de manière à ce que l'ouverture « C » s'emboîte à la goujon. Serre-la avec le tournevis. 3: La parte posterior de la traba tendrá la forma de "C". Inserta el tambor de modo que la abertura de la "C" encaje en el Conector. Apriétalo con un destornillador.



# Étape / Paso 7

(FR)

Montez le Panneau gauche (24) sur le Panneau Supérieur (28) et la Traverse supérieure (15). Insérez le Boitier (E) dans le trou du Panneau Supérieur (28) et dans la Traverse supérieure (15) et fixez avec un tournevis cruciforme.

(ESP)

Coloque el Panel izquierdo (24) en el Panel superior (28) y el Travesaño superior (15). Inserte la Traba (E) en el orificio del Panel Superior (28) y en leTravesaño superior (15) y asegúrela con un destornillador Phillips.

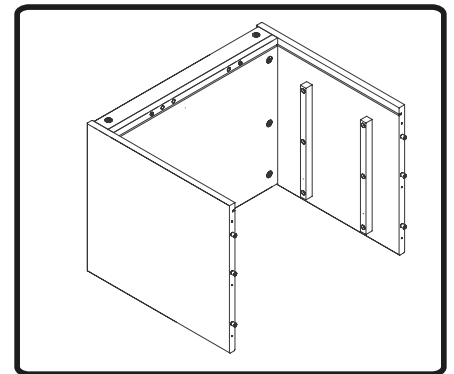
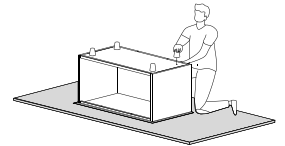
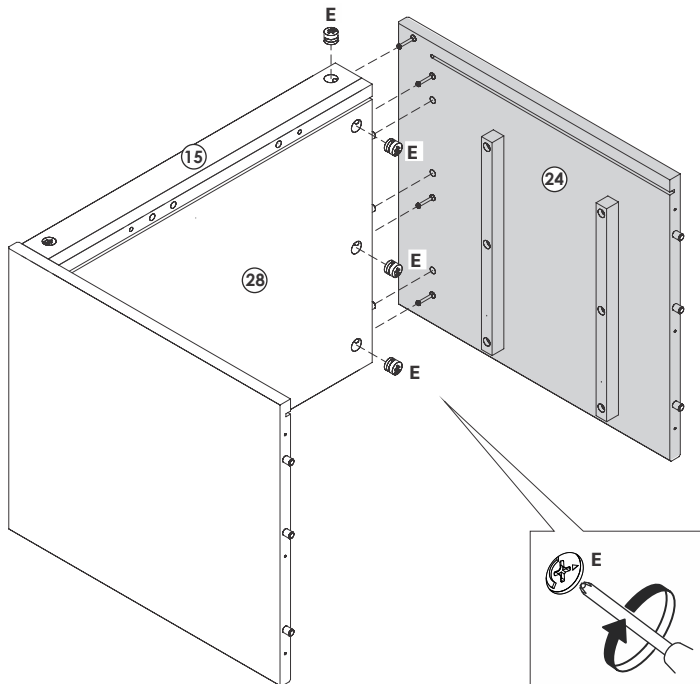

# Étape / Paso 08

(FR)

Insérez l'Arrière (30) entre le Panneau gauche (24), le Panneau droit (28) et le Panneau Supérieur (28).

(ESP)

Inserte la Parte Trasera (30) entre el Panel Izquierdo (24), el Panel Derecho (28) y la Panel Superior (28).

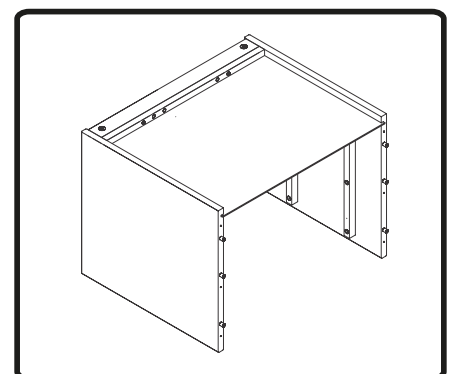
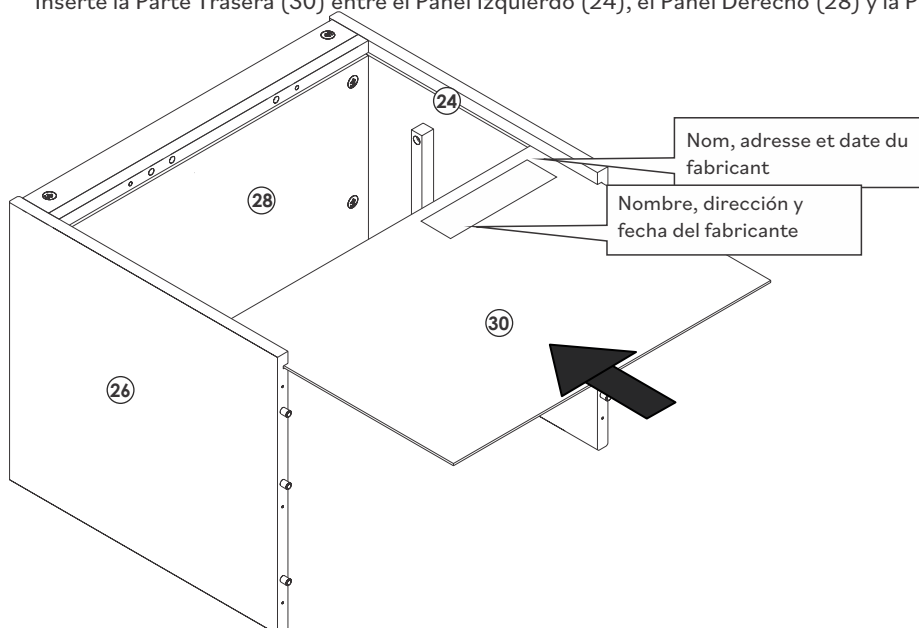

## Étape / Paso 9

(FR)

Fixez le Panneau inférieur (32) au Panneau gauche (24) et au Panneau droit (26) avec la Vis (C) et un tournevis cruciforme.

(ESP)

Fije el Panel Inferior (32) al Panel Izquierdo (24) y al Panel Derecho (26) con el Tornillo (C) y un destornillador Phillips.

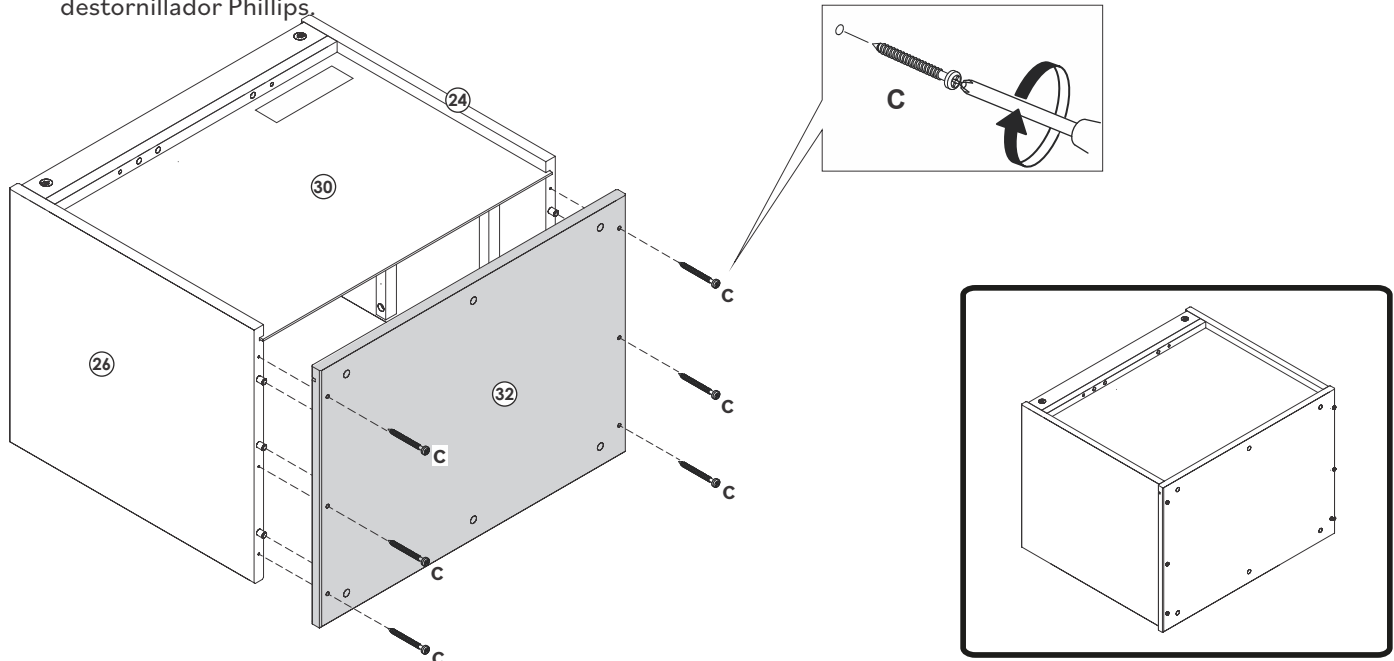
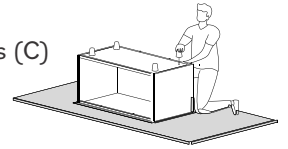

## Étape / Paso 10

(FR)

Fixez le Traverse inférieure avant (34) aux Pieds (36) avec la Vis (C) et un tournevis cruciforme.

(ESP)

Fije el Travesaño delantera inferior (34) a los Pies (36) con el Tornillo (C) y un destornillador Phillips.

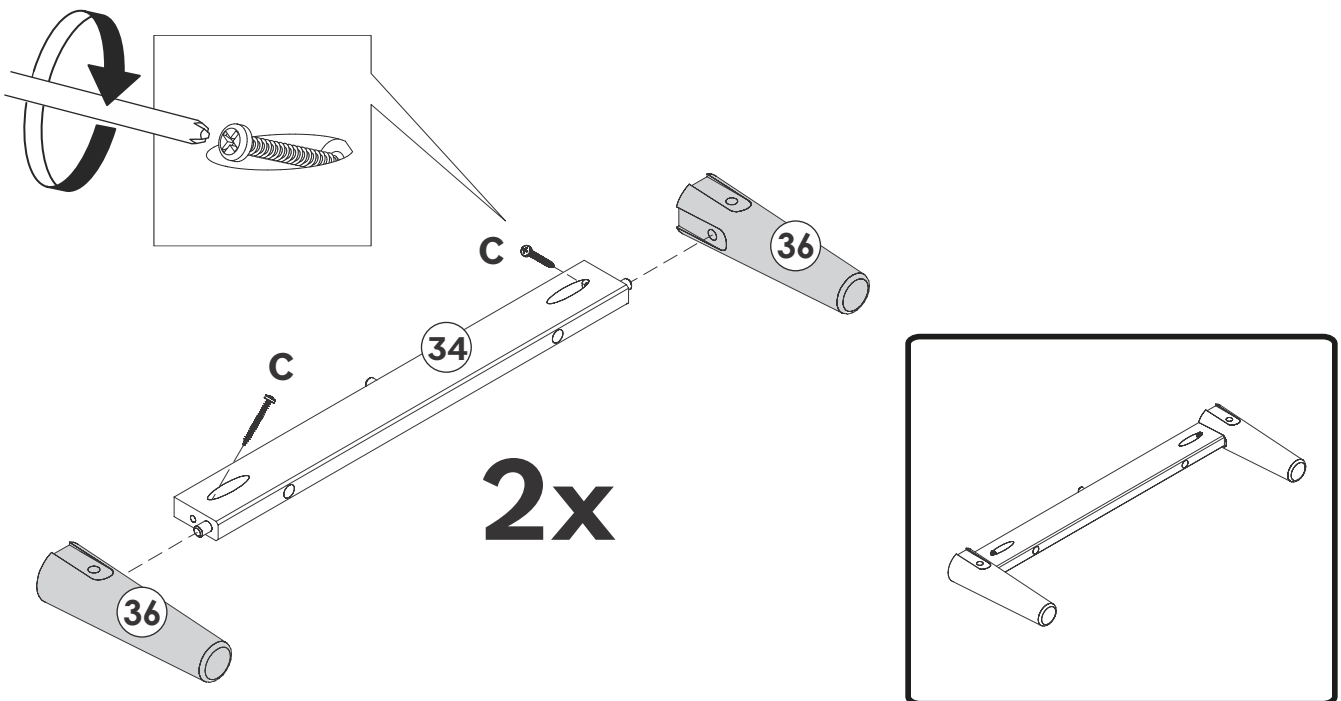

# Étape / Paso 11

(FR)

Fixez la Traverse inférieure (33) aux Pieds (36) avec la Vis (C) et un tournevis cruciforme.

(ESP)

Asegure el Travesaño inferior (33) a los Pies (36) con el Tornillo (C) y un destornillador Phillips.

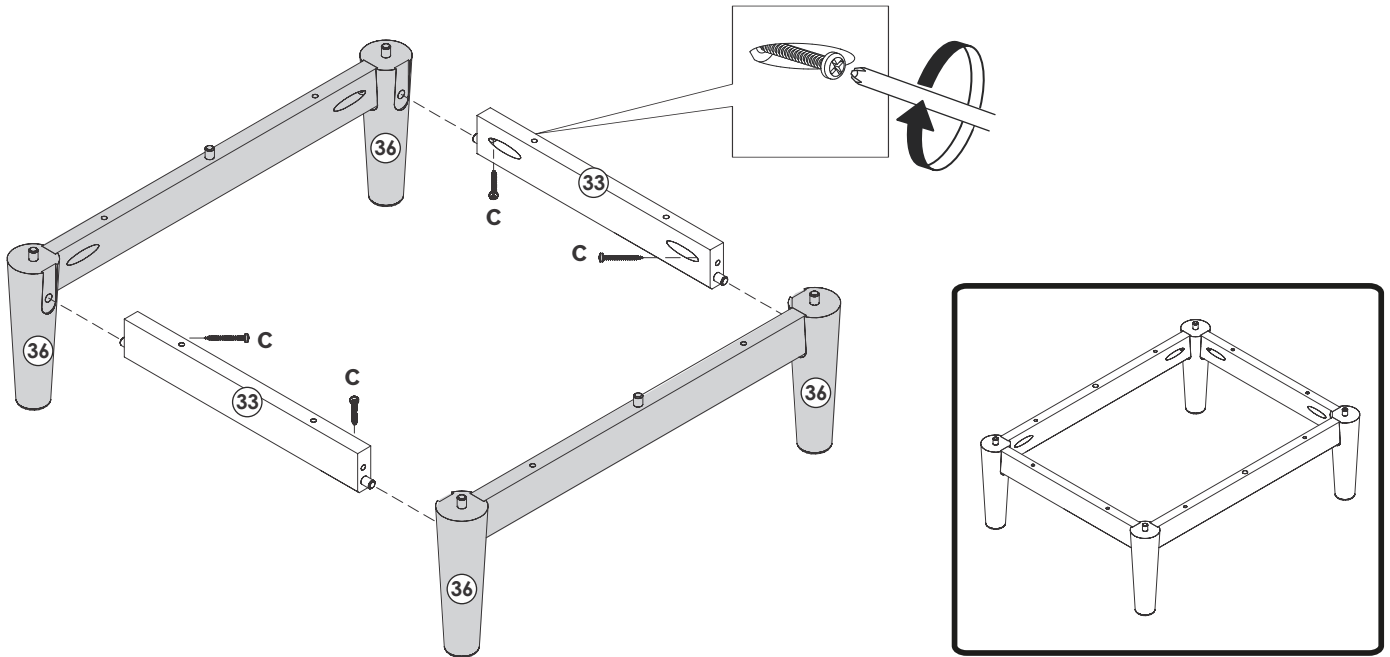
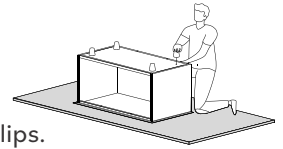

# Étape / Paso 12

(FR)

Montez la Traverse inférieure avant (34) et les Pieds (36) sur le Panneau inférieur (32). Fixez la Traverse inférieure (33) et la Traverse avant inférieure (34) à le Panneau Inférieur (32) avec une Vis (C) et un tournevis cruciforme.

(ESP)

Coloque el Travesaño delantero inferior (34) y los Pies (36) en el Panel inferior (32). Fije el Travesaño inferior (33) y el Travesaño delantero inferior (34) al Panel Inferior (32) con el Tornillo (C) y un destornillador Phillips.

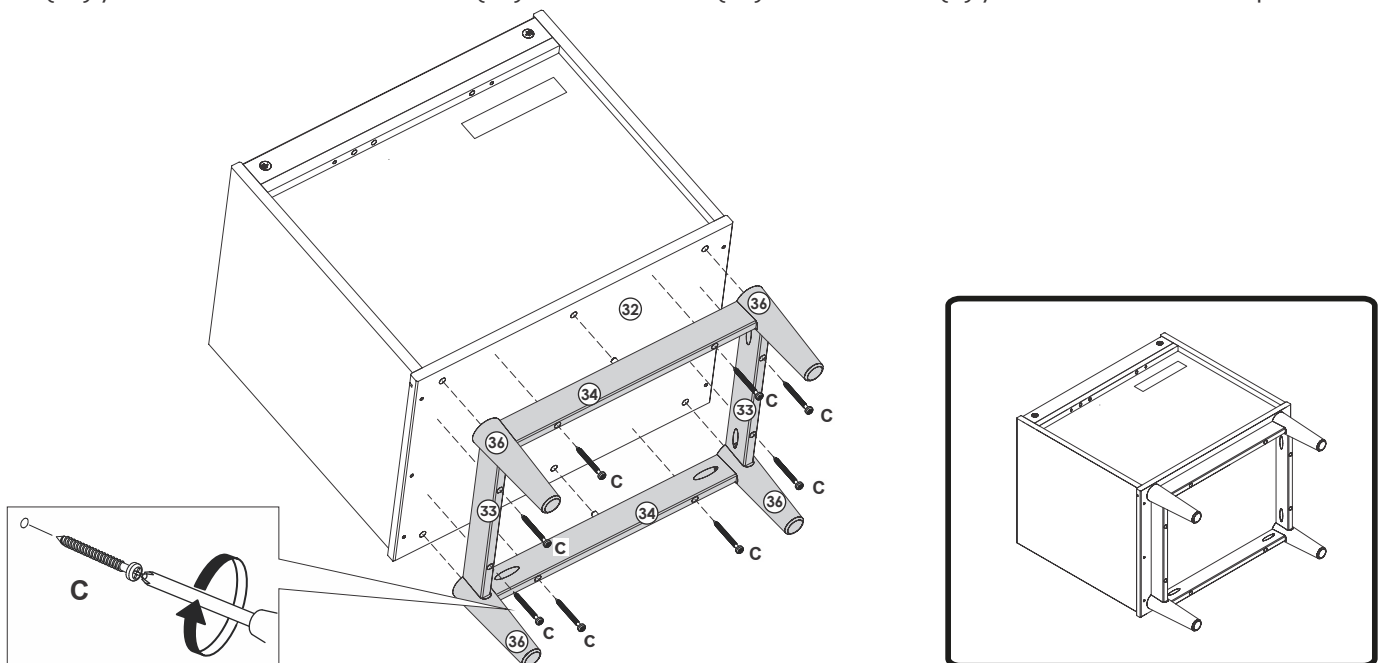

# Étape / Paso 13

(FR)

Insérez la Cheville (A) dans le trou avant de la Glissière du tiroir (17).

(ESP)

Inserte la Espiga (A) en el orificio delantero de la Corredera del cajón (17).

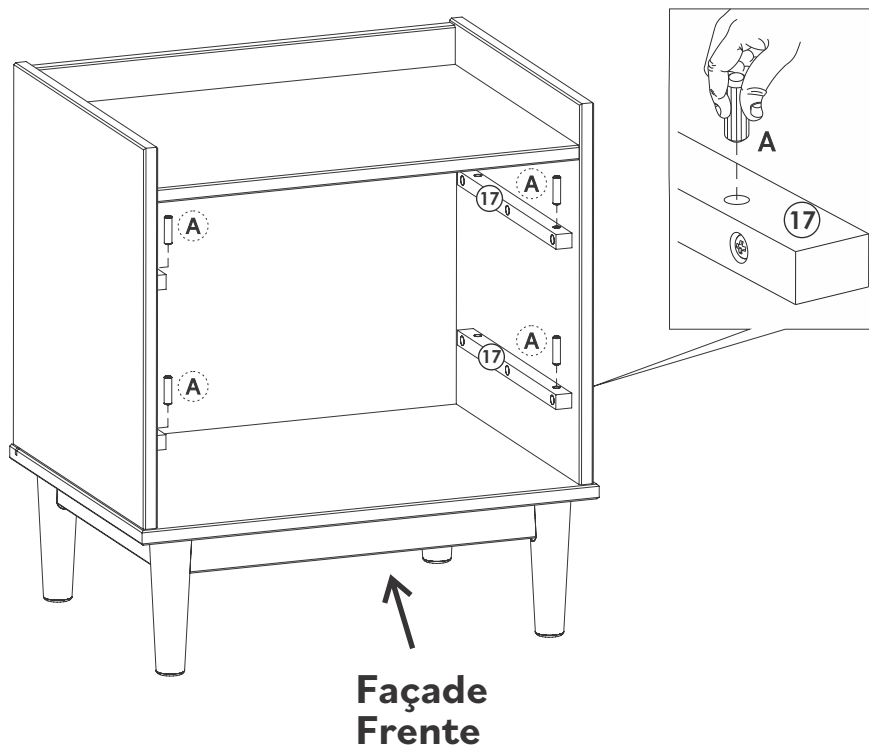
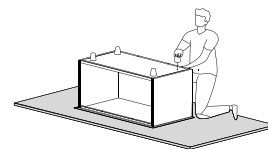

Rotate 90°

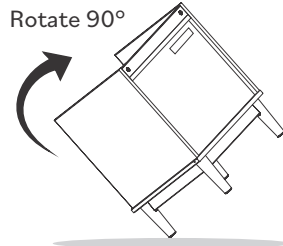

# Étape / Paso 14

(FR)

Fixez le Côté gauche du tiroir (46) et le Côté droit du tiroir (47) à la Façade du tiroir (06) avec la Vis (G) et un tournevis cruciforme.

(ESP)

Fije el Lado izquierdo del cajón (46) y el Lado derecho del cajón (47) al Frente del cajón (06) con el Tornillo (G) y un destornillador Phillips.

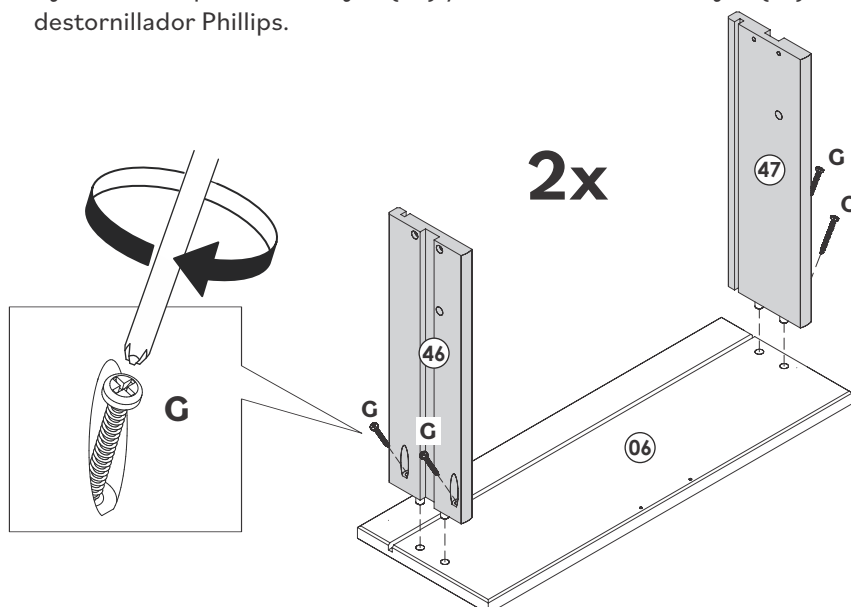

# Étape / Paso 15

(FR)

Insérez le Fond du tiroir (48) entre les fentes sur le Côté gauche de Tiroir (46) et le Côté droit du tiroir (47), puis fixez le Arrière du tiroir (45) avec Vis (G) et un tournevis cruciforme.

(ESP)

Inserte el Inferior del cajón (48) entre las ranuras del Lado izquierdo de Cajón (46) y el Lado derecho del cajón (47), y fije el Trasero del cajón (45) con Tornillo (G) y destornillador Phillips.

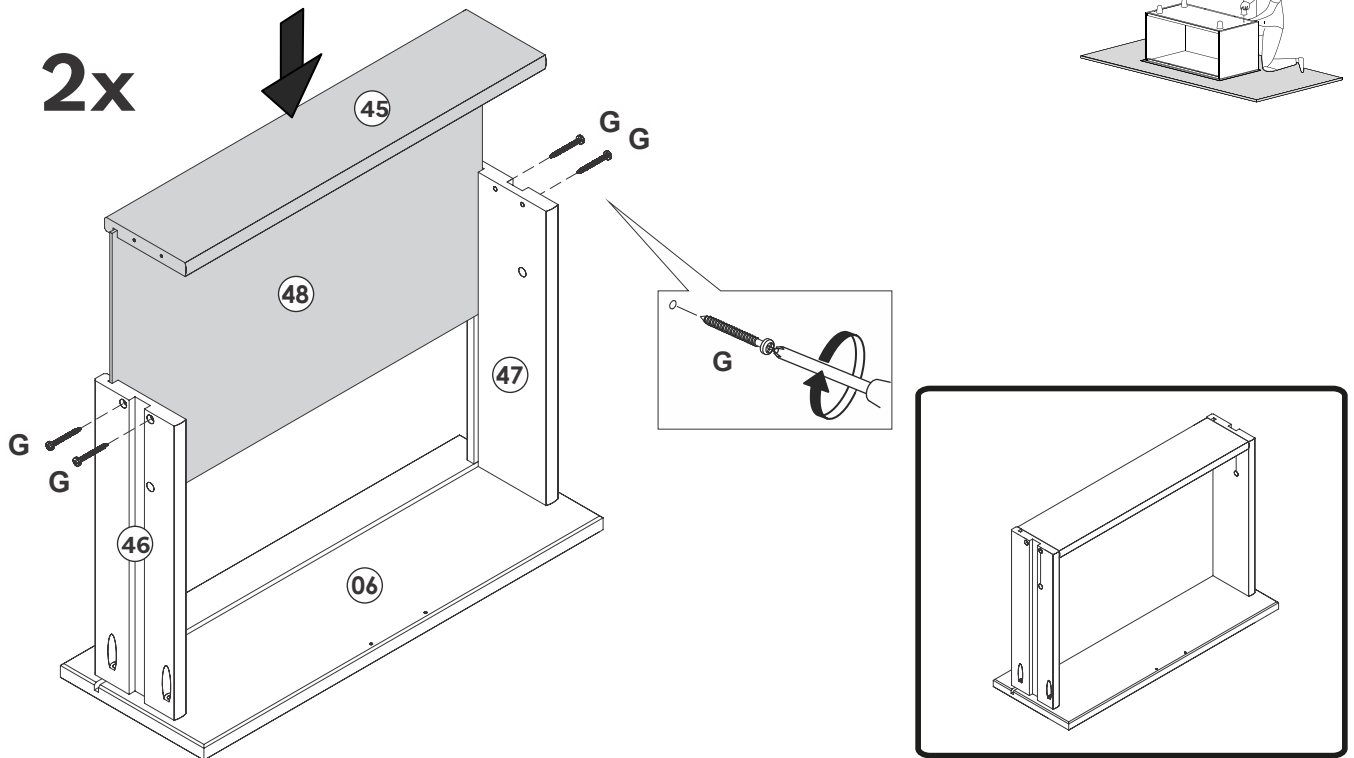

# Étape / Paso 16

(FR)

Fixez la Poignée (J) avec la Vis (D) et un tournevis cruciforme.

(ESP)

Asegure la Manija (J) con el Tornillo (D) y un destornillador Phillips.

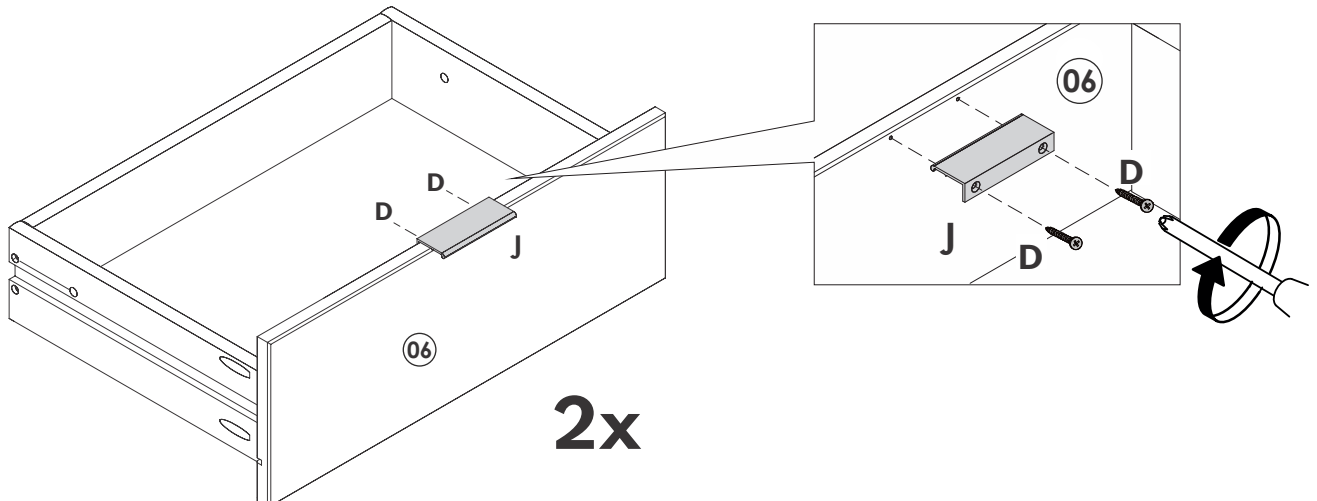

# Étape / Paso 17

(FR)

Placez chaque tiroir un par un à l'intérieur de l'unité, en vous assurant d'avoir passé la cheville en bois qui se trouve sur la glissière du tiroir. Ensuite, insérez les chevilles en bois (H) en place à l'intérieur des tiroirs.  
Remarque : n'enfonchez pas la cheville jusqu'au bout. Elle dépassera légèrement dans le tiroir, ce qui vous permettra de la retirer si nécessaire.

(ESP)

Coloque cada cajón dentro de la unidad, de a uno por vez, asegurándose de pasar la espiga de madera que se encuentra en la corredera del cajón. Luego, inserte las espigas de madera (H) en su lugar dentro de los cajones.  
Tenga en cuenta: No empuje la clavija hasta el fondo. Sobresale levemente dentro del cajón, por lo que podrá quitarla si es necesario.

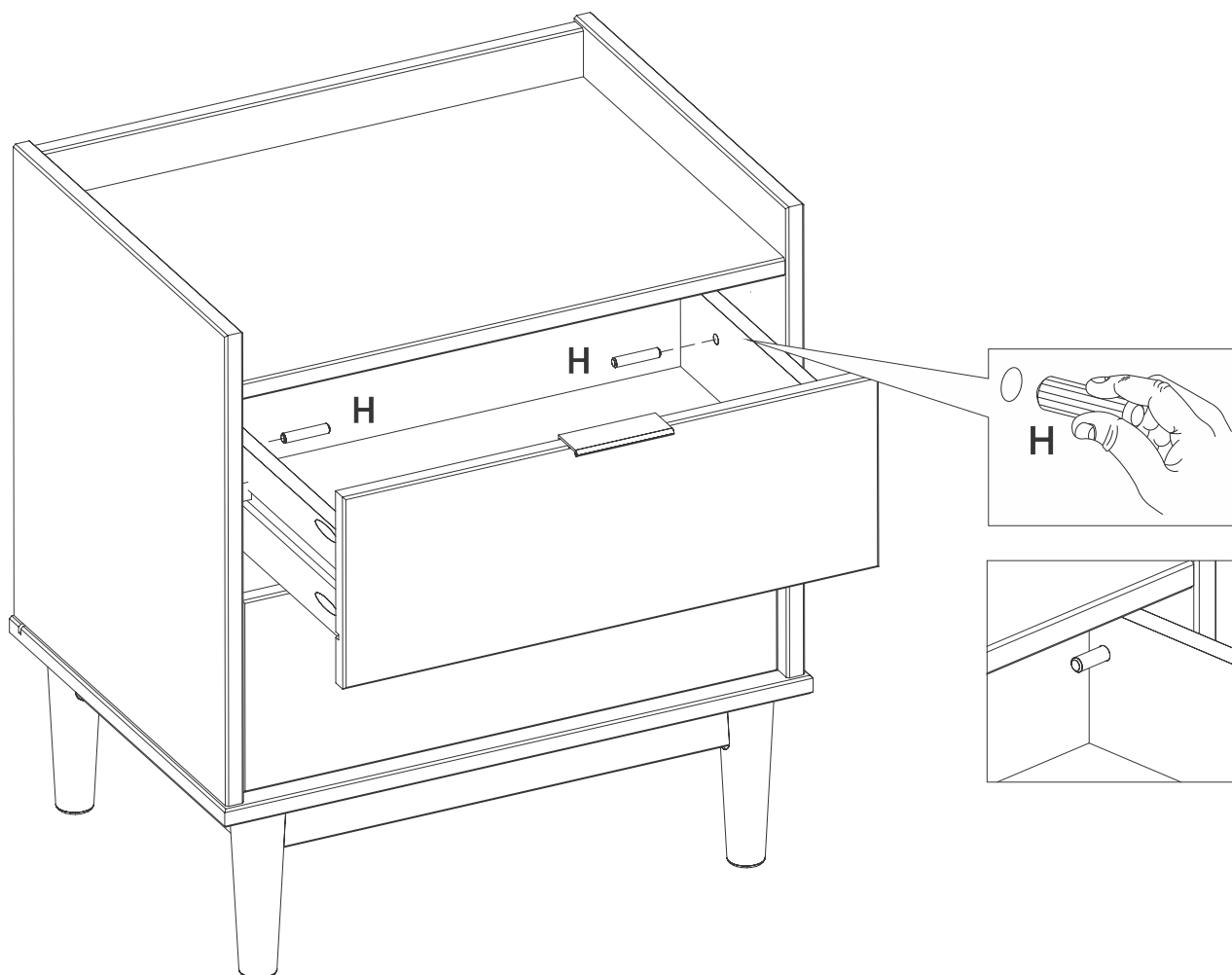

**Vous avez réussi ! Profitez de votre nouvelle commode !  
Lo has conseguido! Disfruta de tu nueva cómoda !**

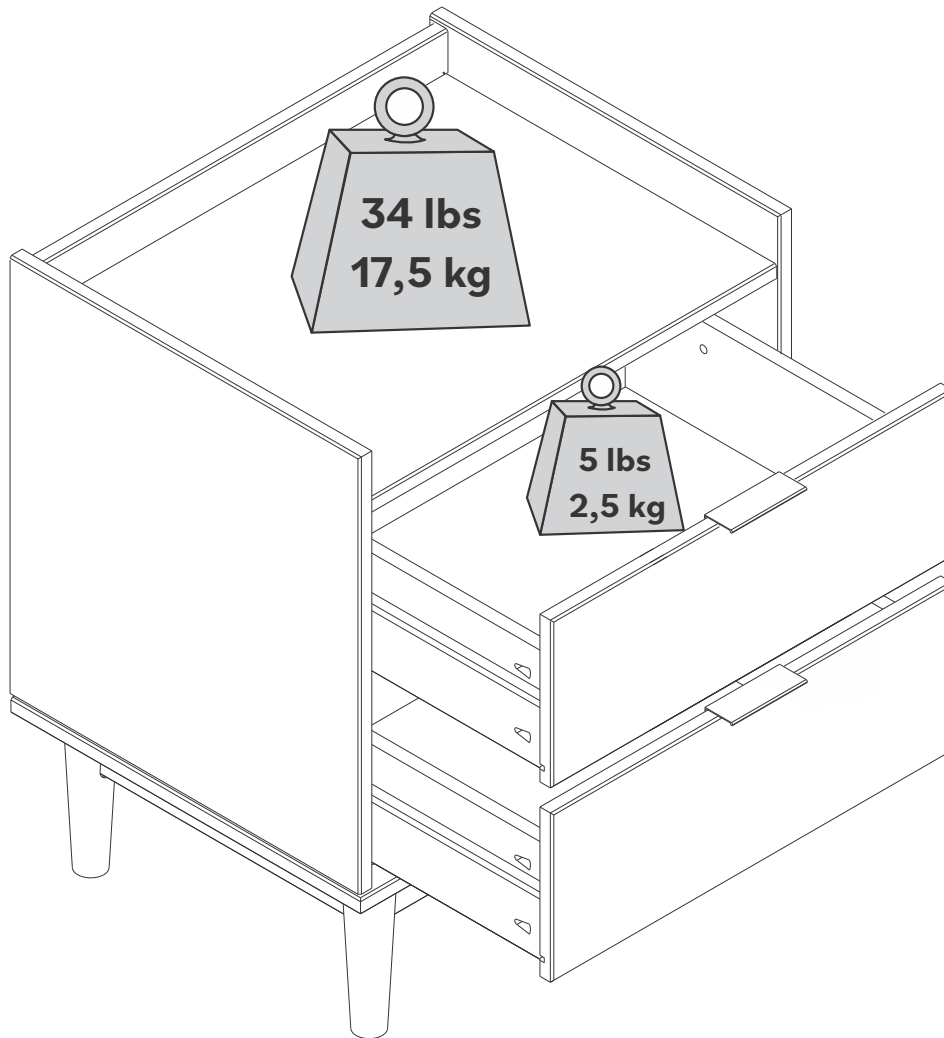

**Félicitations pour votre nouveau meuble!  
Nous serions ravis d'en entendre parler et de le voir.  
Laissez-nous un commentaire ou postez une photo  
avec le mot-clé #mywalkerredisonhome**

**Enhorabuena por su nuevo mueble!  
Nos encantaría conocerlo y verlo.  
Por favor, déjenos un comentario o  
publique una foto con #mywalkerredisonhome**

## Assembler des meubles peut parfois être compliqué.

Notre équipe de service client, située dans l'Utah, est là pour obtenir des informations sur les produits, aider pour l'assemblage d'un produit ou pour tout autre problème de support client.

Appelle-nous **801-433-3008**

Envoie-nous les e-mails à **service@walkeredison.com**

Visite notre site accueil au client à

**walkeredison.com/pages/customer-service**

Nous sommes disponibles pour t'aider du Lundi au Jeudi de 8 am - 5 pm, Vendredi de 8 am - 15 pm MST.

Pour plus de détails sur les vidéos d'assemblage, les instructions d'assemblage, les pièces de rechange et le service client.

**NUMÉRISER ICI.**



Pour le nettoyage, n'utilise jamais d'abrasifs, utilise un chiffon doux et de l'eau avec du savon neutre pour nettoyer les meubles

## Assembler des meubles peut parfois être compliqué.

Notre équipe de service client, située dans l'Utah, est là pour obtenir des informations sur les produits, aider pour l'assemblage d'un produit ou pour tout autre problème de support client.

Appelle-nous **801-433-3008**

Envoie-nous les e-mails à **service@walkeredison.com**

Visite notre site accueil au client à

**walkeredison.com/pages/customer-service**

Nous sommes disponibles pour t'aider du Lundi au Jeudi de 8 am - 5 pm, Vendredi de 8 am - 3 pm MST.

Pour plus de détails sur les vidéos d'assemblage, les instructions d'assemblage, les pièces de rechange et le service client.

**NUMÉRISER ICI.**



Pour le nettoyage, n'utilise jamais d'abrasifs, utilise un chiffon doux et de l'eau avec du savon neutre pour nettoyer les meubles