

# ASSEMBLY INSTRUCTION

**A** Chair Back

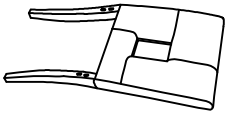

1pc

**B** Seat

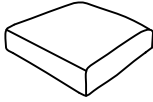

1pc

**C** Front Leg

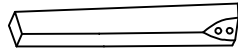

2pcs

**D** Lock Washer



8pcs

**E** Flat Washer

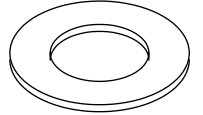

8pcs

**F** Bolt  
5/16"x3"

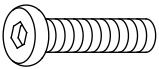

4pcs

**G** Bolt  
5/16"x2-1/2"

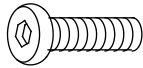

4pcs

**H** Allen Wrench



1pc

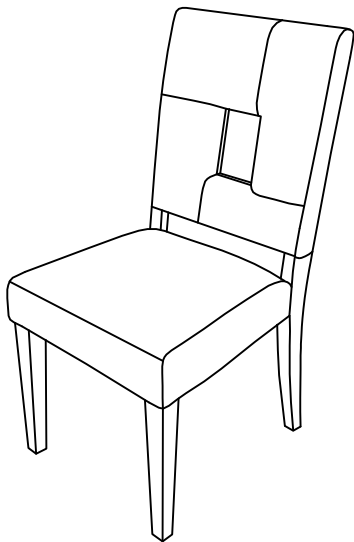

This page lists all the contents included in the box. Please take the time to identify the hardware as well as the individual components to this product. As you unpack and prepare for assembly, place the contents on a carpeted or padded area to protect them from damage.

**1**

Put the seat (B) on a smooth flat surface, attached one front leg (C) to the seat (B) use bolt (G), lock washer (D) and flat washer (E) on both of hole of seat. Turn the allen wrench (H) in bolt (G). But not too tight.

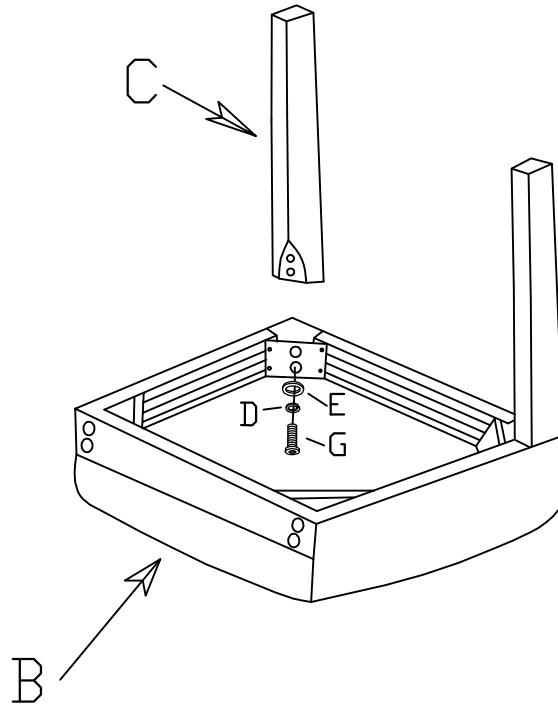
**2**

Put chair back (A) on a smooth flat surface, attached the seat (B) the chair back (A) use the bolt (F), lock washer (D), flat washer (E) in both of hole of seat (B) and chair back (A), turn the allen wrench (H) in bolt (F). But not too tight.

