

PEX PLUMBING SYSTEM

INSTALLATION GUIDE



Table of Contents

Introduction

- Safety Information 3
- PEX Piping 3
- F1960 Expansion Fittings. 3
- F1807 Brass and F2159 Poly Crimp Fittings 3
- Warranty 3
- Applicable System Standards and Certifications 4

PEX Pipe Specifications

- ASTM F876 Temperature and Pressure Ratings 5
- PEX-A Chlorine and UV Resistance 5
- PEX-B Chlorine and UV Resistance 5
- PEX Pipe Dimensions and Characteristics 5
- Fire-Resistant Construction 5

System Sizing and Design

- Friction Loss and Equivalent Length of Tubing 6
- Flow Rate and Velocity 6-7
- Flow Rate and Pressure Loss. 8



Cutting Tools 9

Making a Connection

- Expansion Connection 9
- Troubleshooting F1960/Expansion Connections. 11
- Crimp and Clamp Connection 12-13
- Troubleshooting F1807/F2159 Crimp and Clamp Connections 13

Supporting PEX Piping

- Horizontal and Vertical Support Requirements 14
- Clamps and Risers 15
- Strapping 15
- Bundling 15
- Supporting Large Diameter Valves. 15

Installation Considerations

- Bending PEX Piping 16
- Linear Expansion and Contraction 16-17
- Direct Burial 17
- In a Concrete Slab 18
- Radiant Heating and Cooling Systems 18
- Domestic Hot Water (DHW)/Domestic Hot Water Recirculation (DHW-R) 18
- Insulation 18
- Kinked or Damaged Piping Repair 19
- Thawing Frozen Piping 19
- System Flushing 19
- Pressure Testing 19
- Water System Disinfection 19

Storage Guidelines 20

Handling Guidelines 20

Installation Guidelines 20

Introduction

Jones Stephens' PEX Piping System includes PEX-A pipe for potable water and for oxygen barrier applications, PEX-B pipe for potable water, as well as expansion and crimp-style fittings. Jones Stephens' PEX Piping System solutions are certified, approved to meet industry standards, and manufactured with the highest-quality materials.

THIS MANUAL IS INTENDED AS A GUIDE ONLY. IT IS NOT MEANT TO SUPERSEDE LOCAL PLUMBING CODES.

Safety Information

Before beginning work, read and understand the information presented in this guide. In addition, please refer to the different tool manufacturer's safety warnings and operator manuals.

PEX Piping

PEX piping is made of cross-linked polyethelene. Cross-linked polyethelene is flexible, resistant to plumbing-environment chemicals, and can withstand the high and low temperatures found in plumbing applications. Industry professionals have used PEX piping for over 40 years, because of its durability, easy installation, and resistance to corrosion.

F1960 Expansion Fittings

Jones Stephens' F1960 cold expansion fittings provide precise, secure, and leak-free connections. Made with DZR brass and high-performance poly material, F1960 expansion fittings are corrosion and chlorine/chemical resistant. Approved for use with PEX-A piping.

F1807 Brass and F2159 Polymer Crimp Fittings

Jones Stephens' crimp fittings provide precise, leak-free connections. The secure and reliable crimp fitting method provides full, immediate strength upon installation, with 360-degree uniform pressure. Made with lead-free brass and premium-grade polymer, Jones Stephens' crimp fittings can be used with standard copper PEX crimp rings, copper PEX crimp rings with positioning caps, and stainless steel PEX clamps. Approved for use with both PEX-A and PEX-B piping.

For complete product offering, please see the Jones Stephens PEX catalog or Jones Stephens submittal sheets.

Warranty

Jones Stephens' PEX tubing and PEX fittings have a limited 25-year warranty, when installed in a system comprised of only Jones Stephens' PEX tubing and PEX fittings.

Product Category	When used in combination with	Term of Warranty
Jones Stephens PEX-A Tubing	Jones Stephens Fittings (F1807, F2159 & F1960)	25 years
	Non-Jones Stephens Fittings	11 years
Jones Stephens PEX Fittings (F1807, F2159 & F1960)	Jones Stephens PEX-A Tubing	25 years
	Non-Jones Stephens Tubing	1 year

Product Category	When used in combination with	Term of Warranty
Jones Stephens PEX-B Tubing	Jones Stephens Fittings (F1807 & F2159)	25 years
	Non-Jones Stephens Fittings	11 years
Jones Stephens PEX Fittings (F1807 & F2159)	Jones Stephens PEX-B Tubing	25 years
	Non-Jones Stephens Tubing	1 year

Visit jonesstephens.com to view complete warranty terms.

Applicable System Standards and Certifications

The Jones Stephens' PEX piping system consists of:

PEX-A Pipe for Potable Water and Oxygen Barrier Pipe:

- NSF certified to ASTM F876/877 and CSA B137.5 per NSF/ANSI 14, 61 and 372
- ANSI/NSF14 and ANSI/NSF 61 approved (potable pipe only)
- ASTM F1960, ASTM F2023, ASTM E84, and ASTM E119/UL 263 approved
- CSA B214 approved
- AWWA C904 approved
- Certified by ICC-ES to meet PMG-1559 standard
- CAN/ULC S101 and ULC S102.2 approved

PEX-B Pipe for Potable Water

- NSF certified to ASTM F876/877 and CSA B137.5 per NSF/ANSI 14, 61 and 372
- ASTM F1807, ASTM F2159, ASTM F2023, ASTM E84, ASTM E119/UL 263 approved
- CAN/ULC S101 and ULC S102.2 approved
- F1960 Brass Cold Expansion Fittings:
- Tested and certified to ASTM F1960
- Certified to CSA B137.5-2020
- Certified to NSF/ANSI/CAN 61- 2019, NSF/ANSI 372-2016, and NSF/ANSI 14-2015
- cUPC Listed

F1960 Poly Cold Expansion Fittings:

- Tested and certified to ASTM F1960 and ASTM F877-2020
- Certified to CSA B137.5-2020 and CSA B137.5-2017
- Certified to NSF/ANSI/CAN 61-2018, NSF/ANSI 14-2016, and NSF/ANSI 372-2011
- cUPC Listed

F1807 Brass Crimp Fittings:

- Certified to NSF/ANSI 372-2016, NSF/ANSI 61-2017, and NSF/ANSI 14-2016a
- Certified to ASTM F1807-2019b and CSA B137.5-2017
- NSF/ANSI/CAN 61-2019
- cUPC Listed

F2159 Polymer Crimp Fittings:

- Certified to ASTM F2159-2014 and CSA B137.5-2013
- Certified to ASTM F877-2020 and CSA B137.5-2017
- Certified to NSF/ANSI 14-2015, NSF/ANSI 14-2016a, and NSF/ANSI 372-2011
- Certified to NSF/ANSI/CAN 61-2019
- cUPC listed

PEX Pipe Specifications

ASTM F876 Temperature and Pressure Ratings

Before beginning work, read and understand the information presented in this guide. In addition, please refer to the different tool manufacturer's safety warnings and operator manuals.

Temperature/Pressure Rating	Hydrostatic Design Stress (HDS)
73.4°F at 160 psi (23°C at 11 bar)	630
180°F at 100 psi (82°C at 6.9 bar)	400
200°F at 80 psi (93°C at 5.5 bar)	315

PEX-A Chlorine and UV Resistance

5	1	0	6
Chlorine Resistance 100% recirculation at 140°F	Minimum UV Resistance Maximum exposure of one month		Hydrostatic Design Stress at 73°F/23°C 630 psi

PEX-B Chlorine and UV Resistance

5	3	0	6
Chlorine Resistance 100% recirculation at 140°F	Minimum UV Resistance Maximum exposure of six months		Hydrostatic Design Stress at 73°F/23°C 630 psi

PEX Pipe Dimensions and Characteristics

Pipe Size (in.)	Pipe O.D. (in.)	Pipe I.D. (in.)	Weight of Pipe (lbs/ft)	Volume of Water (gal/100ft)
1/4	0.375	0.241	0.25	0.80
1/2	0.625	0.475	0.05	1.00
5/8	0.750	0.574	0.07	1.30
3/4	0.875	0.671	0.10	1.90
1	1.125	0.862	0.17	3.20
1-1/4	1.375	1.054	0.25	4.70
1-1/2	1.625	1.244	0.35	6.50
2	2.125	1.629	0.60	11.10

Fire-Resistant Construction

PEX-A Pipe for Potable Water and Oxygen Barrier Pipe:

- To qualify for E84/ULC S102.2, you must use insulation that has been rated for E84/ULC S102.2.
- Complies with minimum spacing required for testing (7.87inches centerline to centerline).

Product	Flame Spread	Smoke Development
PEX-A	25 or less	50 or less

System Sizing and Design

The following tables can help with designing plumbing systems.

Friction Loss and Equivalent Length of Tubing

To account for pressure loss through fittings, it is practice to add an equivalent length of tubing for each fitting to system calculation.

PEX Brass Fittings

Type of Fitting	Equivalent Length of Tubing (ft)		
	1/2" Size	3/4" Size	1" Size
Coupling	2.0	0.6	1.3
Elbow 90°	9.4	9.4	10.0
Tee-Branch	10.4	8.9	11.0
Tee-Run	2.2	1.9	2.3

PEX Poly Fittings

Type of Fitting	Equivalent Length of Tubing (ft)		
	1/2" Size	3/4" Size	1" Size
Coupling	7.1	4.8	4.5
Elbow 90°	16.5	17.4	18.0
Tee-Branch	17.9	17.7	17.0
Tee-Run	7.2	6.6	6.0

Flow Rate and Velocity

- Do not exceed 10 ft/sec. velocity for potable cold water distribution.
- Do not exceed 8 ft/sec. velocity for potable hot water distribution.
- Do not exceed 2 ft/sec velocity in the return piping of a potable hot water recirculation system.

Flow Rate and Velocity

Flow Velocity

Flow Rate	Flow Velocity (ft/sec)						
GPM	1/2"	5/8"	3/4"	1"	1-1/4"	1-1/2"	2"
0.50	0.91	0.62	0.45	0.27	0.18	0.13	0.08
0.75	1.36	0.93	0.68	0.41	0.28	0.20	0.12
1.00	1.81	1.24	0.91	0.55	0.37	0.26	0.15
1.50	2.72	1.86	1.36	0.82	0.55	0.40	0.23
2.00	3.62	2.48	1.81	1.10	0.74	0.53	0.31
2.50	4.53	3.10	2.27	1.37	0.92	0.66	0.38
3.00	5.43	3.72	2.72	1.65	1.10	0.79	0.46
3.50	6.34	4.34	3.18	1.92	1.29	0.92	0.54
4.00	7.24	4.96	3.63	2.20	1.47	1.06	0.62
4.50	8.15	5.58	4.08	2.47	1.65	1.19	0.69
5.00	9.05	6.20	4.54	2.75	1.84	1.32	0.77
6.00	10.86	7.44	5.44	3.30	2.21	1.58	0.92
7.00	-	8.68	6.35	3.85	2.57	1.85	1.08
8.00	-	9.92	7.26	4.40	2.94	2.11	1.23
9.00	-	11.16	8.17	4.95	3.31	2.38	1.39
10.00	-	-	9.07	5.50	3.68	2.64	1.54
11.00	-	-	9.98	6.05	4.04	2.90	1.69
12.00	-	-	10.89	6.60	4.41	3.17	1.85
13.00	-	-	11.79	7.15	4.78	3.43	2.00
14.00	-	-	-	7.70	5.15	3.70	2.16
15.00	-	-	-	8.25	5.52	3.96	2.31
16.00	-	-	-	8.80	5.88	4.22	2.46
17.00	-	-	-	9.35	6.25	4.49	2.62
18.00	-	-	-	9.90	6.62	4.75	2.77
19.00	-	-	-	10.45	6.99	5.02	2.92
20.00	-	-	-	11.00	7.35	5.28	3.08
25.00	-	-	-	-	9.19	6.60	3.85
30.00	-	-	-	-	11.03	7.92	4.62
35.00	-	-	-	-	-	9.24	5.39
40.00	-	-	-	-	-	10.65	6.16
45.00	-	-	-	-	-	11.88	6.93
50.00	-	-	-	-	-	-	7.70
55.00	-	-	-	-	-	-	8.47
60.00	-	-	-	-	-	-	9.24
65.00	-	-	-	-	-	-	10.01
70.00	-	-	-	-	-	-	10.78
75.00	-	-	-	-	-	-	11.55

Flow Rate and Pressure Loss

Pressure Loss: 60°F (16°C) Water

Flow Rate	Pressure Loss PSI/100 ft of Pipe						
GPM	1/2"	5/8"	3/4"	1"	1-1/4"	1-1/2"	2"
0.50	0.44	0.18	0.08	0.02	0.01	0.00	0.00
0.75	0.94	0.37	0.17	0.05	0.02	0.01	0.00
1.00	1.59	0.63	0.30	0.09	0.03	0.01	0.00
1.50	3.38	1.35	0.63	0.19	0.07	0.03	0.01
2.00	5.76	2.29	1.07	0.32	0.12	0.05	0.01
2.50	8.70	3.46	1.62	0.48	0.18	0.08	0.02
3.00	12.20	4.86	2.27	0.67	0.25	0.11	0.03
3.50	16.23	6.46	3.02	0.89	0.34	0.15	0.04
4.00	20.78	8.27	3.87	1.14	0.43	0.19	0.05
4.50	25.85	10.29	4.81	1.42	0.53	0.24	0.06
5.00	31.41	12.51	5.85	1.73	0.65	0.29	0.08
6.00	44.03	17.53	8.20	2.42	0.91	0.41	0.11
7.00	–	23.32	10.91	3.22	1.21	0.54	0.15
8.00	–	29.86	13.97	4.13	1.55	0.69	0.19
9.00	–	37.14	17.38	5.14	1.93	0.86	0.23
10.00	–	–	21.12	6.24	2.35	1.05	0.28
11.00	–	–	25.20	7.45	2.80	1.25	0.34
12.00	–	–	29.60	8.75	3.29	1.47	0.40
13.00	–	–	34.33	10.15	3.81	1.70	0.46
14.00	–	–	–	11.64	4.38	1.95	0.53
15.00	–	–	–	13.23	4.97	2.22	0.60
16.00	–	–	–	14.91	5.60	2.50	0.67
17.00	–	–	–	16.68	6.27	2.80	0.75
18.00	–	–	–	18.54	6.97	3.11	0.84
19.00	–	–	–	20.49	7.70	3.44	0.93
20.00	–	–	–	22.54	8.47	3.78	1.02
25.00	–	–	–	–	12.81	5.72	1.54
30.00	–	–	–	–	17.95	8.01	2.16
35.00	–	–	–	–	–	10.66	2.87
40.00	–	–	–	–	–	13.65	3.68
45.00	–	–	–	–	–	13.98	4.57
50.00	–	–	–	–	–	–	4.56
55.00	–	–	–	–	–	–	6.63
60.00	–	–	–	–	–	–	7.79
65.00	–	–	–	–	–	–	9.04
70.00	–	–	–	–	–	–	10.37
75.00	–	–	–	–	–	–	11.78

Cutting Tools

Use cutters specifically approved for PEX piping. Make sure to follow manufacturer’s instructions for sharpening and maintenance of the cutting tools.

Making a Connection

PEX piping can be joined to fittings through cold expansion or crimping.

Expansion Connection

Expansion is a method used to connect PEX-A tubing and ASTM F1960 fittings. A PEX ring is placed on the end of PEX tubing. An expander tool expands the tubing and the ring, allowing fittings to be inserted. The expanded tubing and ring then contract, creating a strong, permanent connection to the fitting.

Approved Tools

Jones Stephens’ approves expansion with all major manufacturers, such as Milwaukee and DEWALT.

Please refer to the tool manufacturer’s recommended inspection and maintenance program in order to keep the tools in proper working condition and follow all operator manual instructions.

Minimum Distance Between Fittings

A minimum distance between fittings is required to avoid damaging the pipe and fittings and to ensure proper connections. Refer to the following table that defines the minimum distance as cut length of pipe.

Recommended Number Of Expansions

Many factors influence the actual number of expansions needed to join PEX pipe and fittings, including:

- Ambient temperature
- Size of pipe and fitting
- Manufacturer of Tool

Fitting Size	Minimum Cut Length of Pipe
1/2"	2"
3/4"	3"
1"	3-1/2"
1-1/4"	4-1/2"
1-1/2"	4-1/2"
2"	6"

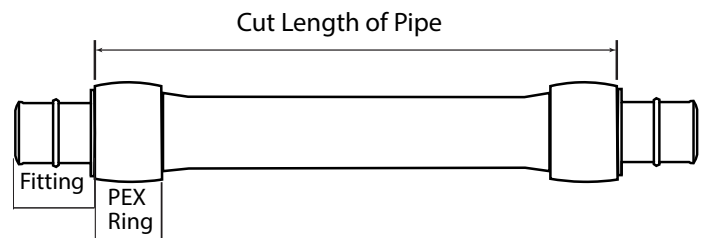

Refer to the tool manufacturer’s recommendations for guidance. Ultimately, the number of expansions needed are the amount needed to fully insert the fitting so that the ring is against the shoulder of the fitting.

Making An Expansion Connection

Expander Tools With Auto Rotation

1. Make a square cut on the PEX-A piping, perpendicular to the length of the piping. Remove any burrs or excess material.
2. Place a PEX ring onto the end of the piping until it reaches the stop. If the ring does not have a stop, extend the ring no more than 1/16" (1mm) over the end of the piping.
3. Insert the expander tool into the piping and hold the piping and tool lightly in place while pressing the trigger to expand the piping. The head will automatically rotate to ensure even expansion. Keep expanding until the piping and ring are snug against the shoulder on the expander head.

NOTE: DO NOT FORCE THE PIPE ONTO THE EXPANDER HEAD. MAKE SURE THE HEAD IS ROTATING.

NOTE: REFERENCE THE TOOL MANUFACTURER'S INSTRUCTIONS FOR RECOMMENDED EXPANSION TECHNIQUE.

4. Immediately remove the expander tool and insert the fitting. Make sure the piping and ring are snug to the fitting shoulder.

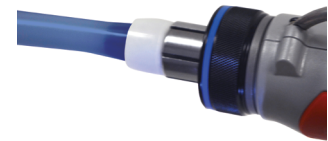
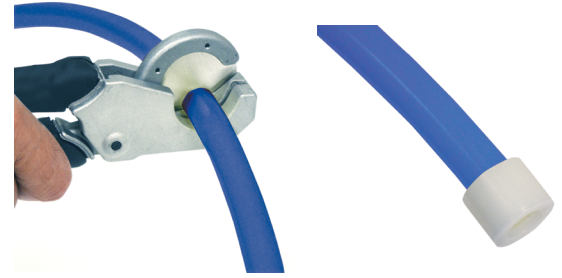

Expander Tools Without Auto Rotation

1. Make a square cut on the PEX piping, perpendicular to the length of the piping. Remove any burrs or excess material.
2. Place a PEX ring onto the end of the piping until it reaches the stop. If the ring does not have a stop, extend the ring no more than 1/16" (1mm) over the end of the piping.
3. Insert the expander tool into the piping and press the trigger to expand the piping.
4. Release the trigger, remove the expander head from the piping, and rotate the head 1/8 of a turn.
5. Insert the head back into the piping and repeat steps 4 and 5 until the piping and ring are snug against the expander head shoulder.

NOTE: ROTATING THE EXPANDER HEAD IS NECESSARY FOR SMOOTH AND EVEN EXPANSION. IF THE EXPANDER HEAD IS NOT ROTATED, THE TOOL WILL CREATE DEEP GROOVES IN THE PIPING THAT CAN CAUSE LEAKS.

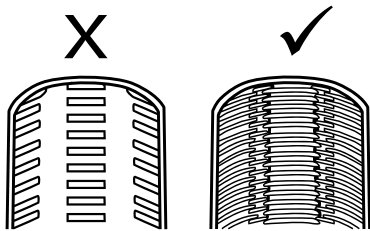

6. Immediately remove the expander tool and insert the fitting. Make sure the piping and ring are snug to the fitting shoulder.

NOTE: DO NOT OVER EXPAND THE PIPE. YOU SHOULD FEEL A SLIGHT RESISTANCE WHEN THE FITTING ENTERS THE PIPE. IF THERE IS NO RESISTANCE, THE PIPE MAY BE OVER EXPANDED. ADDITIONAL TIME WILL BE NEEDED FOR THE PIPE TO SHRINK OVER THE FITTING.

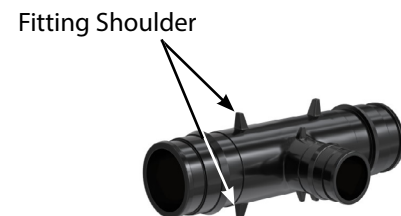
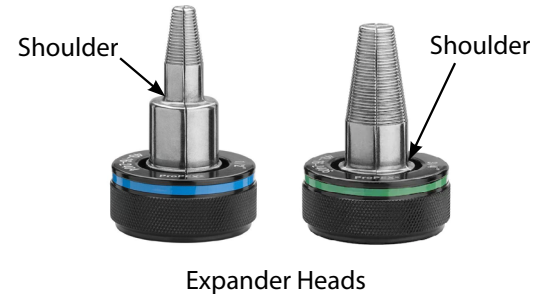

Troubleshooting F1960/Expansion Connections

If you encounter problems when making expansion connections, refer to the following guidelines.

NOTE:

- DO NOT use a heat gun on poly F1960 fittings to quicken contraction time. This could damage the fitting.
- Make sure the PEX ring is flush to the shoulder of the fitting. If there is more than 1/16" (1 mm) between the two, replace the connection by square-cutting the piping 2" from the fitting for 3/8" to 1" pipe and 3" from the fitting for 1-1/4" to 2" pipe. This is done so that you start with unexpanded pipe for the next connection.
- DO NOT reuse poly or brass F1960 fittings or PEX rings.

The Fitting Does Not Slide All Of The Way Into The Piping

- If the fitting does not slide into the piping all the way to the stop, remove the fitting. The piping needs to be expanded more. To avoid over-expanding the piping, do not hold the piping in the expanded position.

The Fittings Do Not Seal

- Check the fitting for nicks or gouges. Damage to fittings will cause them to leak.
- Check if the last expansion is held in the expanded position. If you do not feel any resistance as you insert the fitting into the pipe, the pipe may be overexpanded. Additional time will be needed for the pipe to shrink over the fitting.
- Ensure the expander head is securely tightened onto the tool.
- Check the tool for excess grease on the segment fingers. Remove excess grease before making connections.
- Check the tool for bent segment fingers. If the head does not completely close when the drive unit is retracted or the manual tool handles are open, replace the head.
- Ensure the internal driver cone is not damaged or bent.

The Expansion Head Slips Out Of The Piping

- Make sure grease is not leaking into the piping.
- Make sure the piping and PEX ring are dry.
- Make sure the segment fingers are not damaged or bent.

The PEX Ring Slides On The Piping

- Make sure your hands are clean and dry. Sweat or oils on your hands can cause PEX rings to slide down piping.
- If you suspect the PEX ring might slide down the piping, move the ring out farther over the end of the piping and slowly make a couple of expansions. Then, when the piping and ring begin to expand together, resume normal procedures.
- Place your thumb on the PEX ring to feel for movement and to add support. If you feel movement, follow the procedure in the previous bullet point.

Making Cold Weather Expansions

- The colder the temperature, the longer the time it will take for the piping and the ring to shrink onto a fitting.
- Fewer expansions may be needed when the temperature is below 40°F (4.4°C).

Crimp and Clamp Connection

Crimp and clamp connection is a method used to connect PEX-B or PEX-A tubing and ASTM F1807/F2159 fittings. A crimp copper ring, crimp copper ring with positioning cap, or stainless steel clamp is placed around the PEX-B or PEX-A pipe and fitting and squeezed. The secure and reliable crimp fitting method provides full, immediate strength upon installation, with 360-degree uniform pressure.

Approved Tools

Compatible with other manufacturer's crimp and clamp tools for crimp connections if calibrated correctly. Please refer to the tool manufacturer's recommended inspection and maintenance program in order to keep the tools in proper working condition.

Making a Crimp Connection

Inspect all tools prior to beginning work. Clean and make any necessary repairs or calibrations.

- Using a cutting tool designed for use with PEX pipe, measure and cut pipe to desired length. Cut at 90 degrees, making sure not to crush or deform the outer diameter. Make a square cut, as an uneven or jagged cut could result in an improper connection.



- Slide the compression ring or clamp onto the PEX pipe until it reaches approximately 1/8" below the cut end.



Ring



Clamp

- Insert the fitting into the PEX pipe until the cut end rests against the stop on the fitting.



Ring



Clamp

- Using the proper crimp tool, compress the ring or clamp until the tool has completed its cycle. For a ring, use a PEX crimp tool to compress. For a clamp, use a PEX steel clamp tool to compress.

Verify that the connection is complete and secure. For the ring connection, use a go-no-go gauge. For the clamping rings, assure the clamped connection has achieved proper closure on the ears.



Ring



Clamp

IF USING JONES STEPHEN'S PEX CRIMP RINGS WITH POSITIONING CAPS:

- A. Slide the PEX crimp ring with a positioning cap onto the PEX pipe until it reaches the end of the cut pipe. You should be able to see the PEX pipe through the cap window
- B. The positioning cap will position the ring 1/8" from the cut end and hold the ring in place.

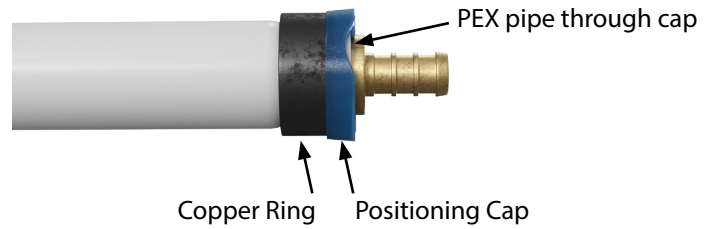

Troubleshooting F1807/F2159 Crimp and Clamp Connections

If the fittings are not sealing properly:

1. Is the fitting damaged or burred? If yes, cut off the fitting and replace.
2. Is the tubing flush with the shoulder of the fitting? If not, cut off the fitting and replace.
3. Is the ring smooth and concentric? No ridges or gaps should appear. If not, cut off the fitting and replace.
4. Is the connection complete and secure? The tubing should be resting firmly against the shoulder of the fitting. The ring or clamp should be approximately 1/8" from the end of the tubing. If not, cut off the fitting and replace.
5. Pressure test per local codes. If there is a leak, cut off the fitting and replace.

NOTE: WHEN REPLACING THE FITTING, CUT THE PEX PIPING JUST PAST THE END OF THE FITTING.

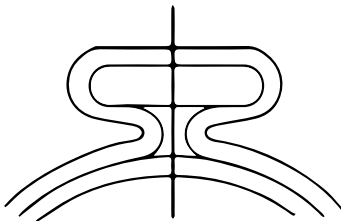

Clamped connection proper closure on ears.

Supporting PEX Piping

The following are general guidelines for supporting PEX pipe.

- Make sure supports and clamps are free of sharp edges.
- Use copper tube size (CTS) supports and clamps.
- Do not overtighten supports or clamps.
- Do not strap pipe directly to drain, waste, vent (DWV) piping systems.
- If using a multiport tee, support the inlet pipe within 6" of the tee.
- Follow local code requirements when supporting PEX piping. Remember that local code requirements do not take into account expansion or contraction of PEX piping. See *Linear Expansion and Contraction*.

Horizontal and Vertical Support Requirements

The following table shows the maximum spacing for horizontal and vertical supports of PEX piping.

Pipe Size	Maximum Horizontal Spacing		Maximum Vertical Spacing		
	UPC/IPC/UPC/UMC	NPCC (Canada)	IPC/IMC	UPC/UMC	NPCC (Canada)
1" and smaller PEX Pipe	32 inches	0.8 m	10 feet * For 2" pipe and smaller, install a guide midway between vertical supports that prevents horizontal movement.	Each floor/base and mid-story guides.	Every other floor/base, not to exceed 7-1/2 m.
1-1/4" and larger PEX Pipe	48 inches				

Vertical Support Requirements

In-Wall and risers are the two types of vertical pipe runs. In-Wall piping typically stays within the same room or floor, is usually <1" in diameter, and often is the dedicated supply line to a fixture. Riser piping carries water from a lower floor to a higher floor, is usually >1" in diameter, and often requires fire-penetration sealants.

Pipe Protection

A stud guard is used to protect plumbing from penetration by nails or screws. When installing a stud guard for PEX piping, please ensure the stud guard overlaps the PEX piping by 1" on each side.

EVERY OTHER FLOOR, INSTALL A RISER CLAMP

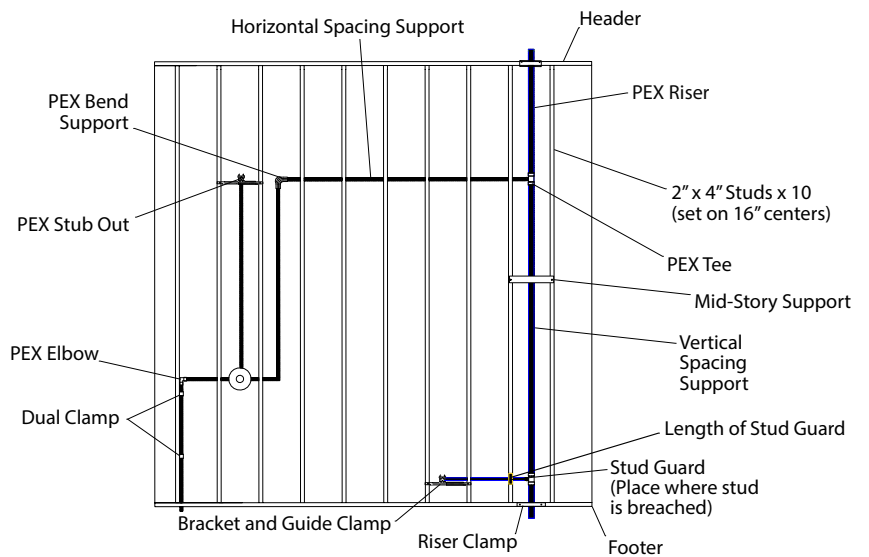

1ST FLOOR

Clamps and Risers

To prevent damage to fittings, Jones Stephens recommends the minimum distances between clamps and fittings in the table below.

Pipe Size	Minimum Distance
1/2"	1-1/4" (32mm)
5/8"	1-1/2" (38mm)
3/4"	1-3/4" (44mm)
1"	2-1/4" (57mm)
1-1/4"	2-3/4" (70mm)
1-1/2"	3-1/4" (83mm)
2"	4-1/4" (108mm)

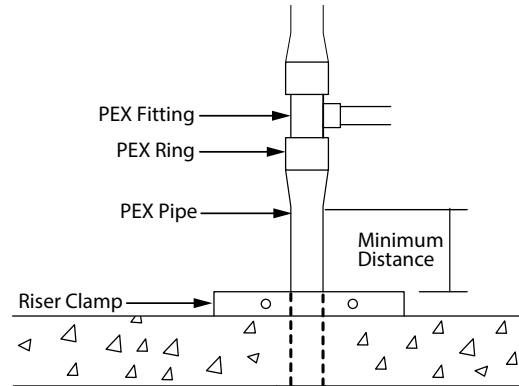

Strapping

Approved methods to strap PEX piping include:

- Stand-off brackets (Must be used to isolate piping from other MEP systems).
- Pipe talons
- Loop or clevis hangers (clamps and hangers)
- Cable ties (Do not use cable ties for suspension alone).
- Steel straps (must have no sharp edges or be coated).

Bundling

Observe the following guidelines when bundling parallel runs of PEX piping:

- Do not bundle hot and cold pipes together.
- May use cable ties to maintain a bundle of hot or cold pipes.
- Do not use cable ties as the only means of supporting a bundle. Cable ties are not approved for supporting piping.
- Do not use duct tape for bundling.
- Support the entire bundle at the required on-center distance. See local code for requirements.

Supporting Large Diameter Valves

Pipe Size	Valve Type	Support Distance
1-1/4" – 2"	Ball	18" (46cm)

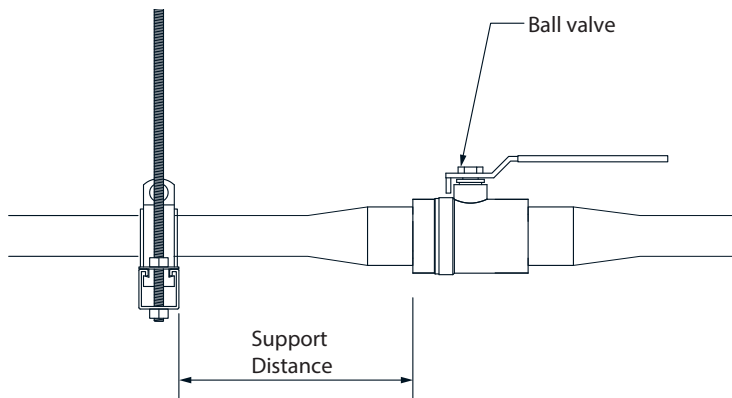

Installation Considerations

Bending PEX Piping

The minimum bend radius of Jones Stephens' PEX piping is six times (6x) the outside diameter (O.D.). Bend supports are available to support 90° bends. If a proper bend is not possible, consider using an elbow. If using coiled piping and bending against the coil direction, the minimum bend radius should be increased by three.

Do not change piping direction immediately after a PEX connection. This can place undue stress on connections and fittings. Jones Stephens recommends a minimum distance of 2 x the outside diameter (O.D.) before changing pipe direction.

Tubing Size	Min. Bending Radius	2 x (OD)
1/2"	3.75" (95mm)	1.25"
3/4"	5.25" (133mm)	1.75"
1"	6.75" (171mm)	2.25"
1-1/4"	8.25" (210mm)	2.75"
1-1/2"	9.75" (248mm)	3.25"
2"	12.75" (324mm)	4.25"

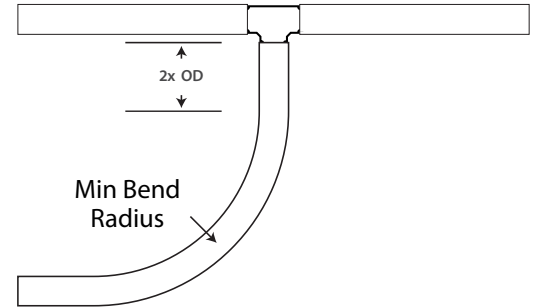

Linear Expansion and Contraction

PEX piping expands and contracts when there are temperature changes in the environment or in the liquid in the pipe. The greater the change, the more stress is placed on piping and fittings.

Formula

Jones Stephens' PEX -A expands and contracts at a rate of 1.1" per 100' per 10 degree change in temperature (delta T).

Mitigation

There are several different methods to help mitigate the effects of linear expansion and contraction.

Slack

Allowing some slack in piping runs helps to lessen damage from piping contraction. Do not install hangers or tube supports too tightly. Allow for 1/8" of slack for every foot of piping installed.

Loops/Offsets

Changing piping direction can help mitigate stress on the system.

- For piping below 3/4", loops and offsets can help absorb linear expansion.
- For piping above 1", there are three types of offsets used: corner, U-type, and Z-type.

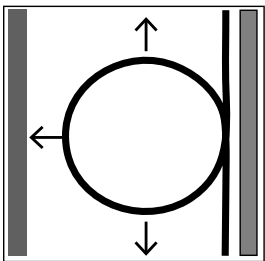

Using a loop to accommodate expansion

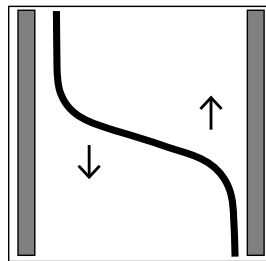

Offsets provide room for expansion

Corner Offset

A 90° elbow is used at a corner.

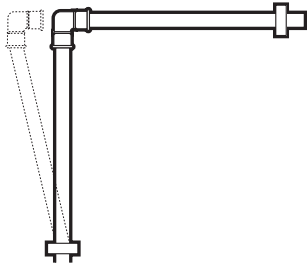

Corner Offset

U-Type Offset

Four 90° elbows are used to create a "U" shape.

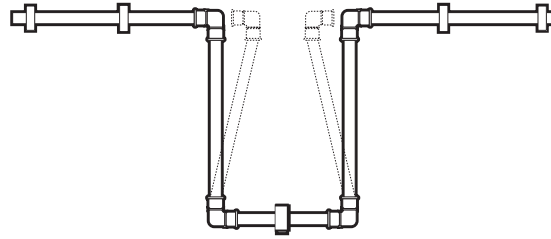

U-Type Looped Offset

Z-Type Offset

Two 90° elbows are used to create a "Z" shape.

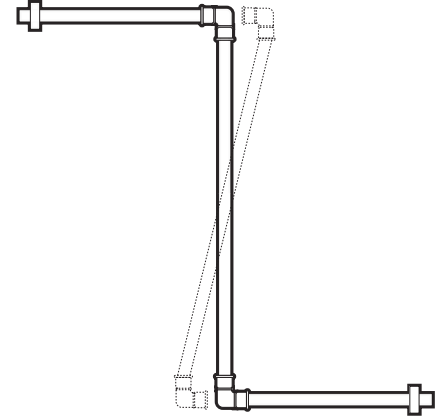

Z-Type Offset

Direct Burial

Follow local code when installing PEX pipe below-grade.

Trench Bottom Preparation

- Supporting soil must provide stable and continuous support for piping.
- Supporting soil must be free of sharp objects, such as large rocks or glass.
- If the supporting soil is in poor condition, it will be necessary to remove six inches of soil and replace it with appropriate material to provide a stable base (pea gravel, coarse sand, etc.). See local code for additional requirements.

Installation

It is recommended to install the pipe in one continuous run, without fittings.

Lay the piping in the trench, snaking it slightly side to side and leaving sufficient slack in the line to provide for expansion or contraction due to temperature change.

NOTE: DO NOT USE BLOCKING TO SUPPORT THE PIPING OR CHANGE THE PIPING GRADE.

NOTE: DO NOT INSTALL PIPING ABOVE OR BELOW CESSPOOLS, SEPTIC TANKS, SEPTIC-TANK DRAINAGE FIELDS, OR PITS.

CAUTION: DO NOT INSTALL PIPING IN SOIL ENVIRONMENTS CONTAMINATED WITH SOLVENTS, FUELS, ORGANIC PESTICIDES, OR SIMILAR CHEMICALS.

Fittings

Jones Stephens' fittings are not approved for use in direct burial.

Backfill

- Pressurize the piping before backfilling.
- Backfill with 3/4" maximum particle-sized sand or gravel, to a depth of four to six inches. Backfill should not contain sharp objects, large rocks, or be composed of silts, plastic clays, or organic material.
- Compact the backfill to support the piping. In areas with heavy traffic loads, compact the backfill to 90% of soil density.

In a Concrete Slab

Follow local code when installing PEX pipe in a concrete slab.

Installation

- Protect piping at the points where it enters and exits a concrete slab with 0.025" thick protective material that allows expansion and contraction of the piping. Poly sleeving, pipe insulation, or corrugated, rigid conduit can be used.
- It is recommended to install the pipe in one continuous run without fittings in the slab.
- If necessary, repairs can be made in slab. Jones Stephens recommends the repair pipe and fitting(s) be wrapped.
- After installation, pressurize the piping before pouring the concrete.

Fittings

Jones Stephens' fittings are not approved for use in a concrete slab, with the exception of repairs where fittings must be wrapped.

Radiant Heating and Cooling Systems

Jones Stephens' PEX-A Oxygen Barrier piping and F1960, F1807 and F2159 fittings are approved for use in radiant heating and cooling systems.

Domestic Hot Water (DHW)/Domestic Hot Water Recirculation (DHW-R)

Jones Stephens recommends that DHW temperature does not exceed 200°F (93°C) and that DHW-R temperature does not exceed 140°F (60°C). Exceeding these temperatures can cause damage to the PEX piping system. A standard temperature setting range for DHW/DHW-R is 115°F (46°C) to 122°F (50°C).

For systems with domestic hot water recirculation (DHW-R), maintain flow velocity at or below 2ft/sec. Failure to do so can cause pinhole leaks.

Insulation

General

Wherever metal pipe requires insulation to control condensation, PEX pipe likely will too. Follow local code.

As a general practice, tubing that runs through unheated areas, such as attics, exterior walls, or the outdoors should be insulated in cold-weather areas. Check local code for requirements.

To qualify for E84/ULC S102.2, you must use insulation that has been rated for E84/ULC S102.2.

Near Lighting

If installing Jones Stephens' PEX pipe within 6" of fluorescent lighting, use closed-cell or fiberglass pipe insulation to a distance of at least 18" from the light source to insulate the pipe from heat exposure. Make sure the pipe is at least 1" from the fluorescent light source.

If installing Jones Stephens' PEX pipe within three feet of fluorescent lighting (beneath or to the side), use closed-cell pipe insulation, HDPE poly sheathing, or another suitable pipe-covering material to a distance of at least 18" from the light source to protect the pipe from UV light.

If installing Jones Stephens' PEX pipe within 18" of a LED light source, cover the pipe with foam insulation or protective material to a distance of at least 18" from the light source.

If it is necessary to install closer than 12" to Type non-I.C. recessed light fixtures, use closed-cell polyethylene, polyolefin, or other suitable pipe insulation around the piping that is rated to withstand the heat generated by the fixture. Make sure the piping is insulated 12" out from all sides of the recessed light fixture and that there is a minimum 3" clearance from the fixture to any thermal insulation.

Spray Foam

Closed-Cell spray foam can be used with/directly on Jones Stephens' PEX piping, but care must be taken that the maximum temperature of 250°F/121°C is not exceeded during the foam setting process. One inch of foam will create a temperature of 130°F/54°C, and two inches will create a temperature of 200°F/93°C. Apply a light, initial layer of foam to protect piping, then, depending on the inches of lift needed, spray one or more layers, allowing the heat from the foam application to dissipate. **DO NOT USE CLOSED-CELL SPRAY FOAM TO SEAL IN-A-CONCRETE-SLAB PENETRATIONS.**

Spray-Foam insulation cannot be used on Jones Stephens' fittings.

Kinked or Damaged Piping Repair

Use the following directions to repair PEX piping, depending on the type of PEX piping and the damage.

If PEX-A piping is kinked (not punctured):

1. Depressurize the system.
2. Straighten the kinked piping.
3. Use a heat gun to apply heat evenly to the kinked piping, until it returns to its original form.

NOTE: DO NOT APPLY OPEN FLAME OR HEAT ABOVE 338°F/170°C.

4. Let the piping cool to room temperature.

If PEX-A or PEX-B piping is punctured or damaged:

1. Using a PEX piping cutter, cut out the damaged section of piping.
2. If the PEX piping can be stretched to join the two ends, proceed to step three. If the piping cannot be stretched, prepare a new piece of PEX piping that is slightly larger than the piece removed.
3. Use the expansion or crimp method with an approved coupling to join the piping ends.

Thawing Frozen Piping

If your PEX piping freezes, address the cause of the freezing, such as insufficient heat or insulation.

Use one or more of the following methods to thaw frozen PEX piping:

- Wrap hot towels around the affected piping
- Pour hot water over the affected piping
- Heat the affected area slowly with a hair dryer. Check the piping with your hand to make sure it does not get too hot.

NOTE: WHILE PEX PIPING IS FLEXIBLE AND CAN EXPAND TO ACCOMMODATE FREEZING WATER, PEX FITTINGS AND CONNECTIONS ARE NOT FLEXIBLE AND MAY BE ADVERSELY AFFECTED BY FREEZING. CHECK THE CONDITION OF THE FITTINGS AND CONNECTIONS AFTER PIPING HAS FROZEN. MAKE SURE THERE ARE NO LEAKS.

System Flushing

Flush potable water plumbing systems, including fixtures, with fresh, potable water before using. Additional local code requirements may apply.

Pressure Testing

Test according to local code requirements. Recommended test pressure is 100 psi (6.9 bar), or 25 (1.7 bar) psi above working pressure.

Water System Disinfection

Water systems can be disinfected through chemical or thermal methods. Neither method should exceed 80 psi system pressure. Follow local plumbing code for disinfection practices of water piping systems.

Chemical Disinfection

Disinfection chemicals are strong oxidizers and can reduce the life of a PEX piping system. Make sure to flush the system with clean, potable water after disinfecting the system with chemicals.

Thermal Disinfection

To disinfect a water system thermally, raise the water temperature to 160°F (71°C) and flush for five minutes minimum to 24 hours maximum (per month).

Storage Guidelines

The following guidelines are for storing PEX piping and fittings.

- Do not store pipe where it will be directly exposed to sunlight.
- Do not use in areas outside of the acceptable temperature and pressure ratings.

Handling Guidelines

The following guidelines are for handling PEX piping and fittings.

- Do not expose to blunt impact.
- Do not subject to open flame.
- Do not use to convey natural gas, medical gas, or compressed air.
- Do not weld or apply adhesives, tape, or glue to PEX pipe. Polyethylene tape can be used temporarily, if removed after installation.
- Do not allow organic chemicals, strong acids, or strong bases; petroleum or solvent-based paints, greases, or sealants; or rodents, insects, or other pests to come into contact with Jones Stephens' PEX pipe or fittings.
- Do not install in soil contaminated with solvents, fuels, organic pesticides or compounds, or other materials that may cause permeation, corrosion, degradation or structural failure.

Installation Guidelines

The following guidelines are for handling PEX piping and fittings.

- Do not use pipe as an electrical ground.
- Only use approved firestop materials with Jones Stephens' PEX pipe.
- Isolate piping from other mechanical, electrical, and plumbing (MEP) systems.
- Do not weld, solder, braze, or fusion-weld within 18" of PEX pipe or fittings in the same waterline.
- Do not install within 6" of any gas appliance vents.
- PEX tubing may be connected directly to residential electric tank or tankless (instantaneous) water heaters, if the local code and water heater manufacturer allows. When connecting PEX tube to gas tank or tankless water heaters, the tube must be kept at least six inches away from the exhaust vent of the heater. Flexible metal water heater connectors may be needed in some instances.
- Do not install Jones Stephens' PEX pipe between the tub spout and the tub/shower valve.
- Install at least 2" from Type I.C. recessed light fixtures.
- Install at least 12" from Type non-I.C. recessed light fixtures.
- Do not reuse poly or brass fittings.
- Do not subject Jones Stephens' fittings to bending loads greater than 100 lbs.
- Any time a stud is breached, Jones Stephens recommends using a stud guard.
- Use grommets when installing pipe through steel framing.
- Use water hammer arrestors as required by local code.
- Use Steel Plate Protectors to protect Jones Stephens' PEX piping from damage from drywall, paneling, nails, or screws.
- If using a compression fitting on Jones Stephens' PEX pipe, you must use an insert stiffener sleeve inside the pipe at the connection.

