

Edaline LED Wall Sconce
Satin Nickel

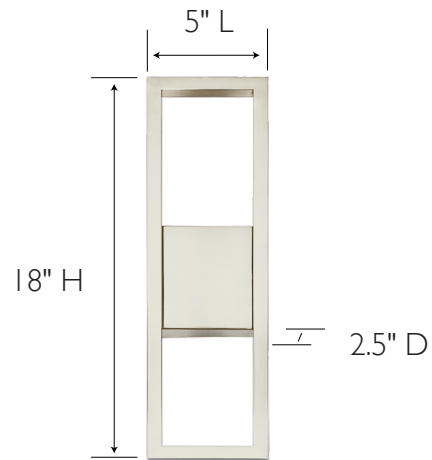

SPECIFICATIONS

MOUNTING:	Wall Mount	LED BRIGHTNESS (LUMENS):	790
SLOPED CEILING ADAPTABLE:	N/A	LED COLOR CORRELATED TEMPERATURE (CCT):	3000K
LAMP TYPE 1:	Integrated 19W LED	LED COLOR RENDERING INDEX (CRI):	90
BULB INCLUDED:	N/A	LED EFFICACY:	41.58
WATTS PER BULB:	19W	LED AVERAGE RATED LIFE:	30000h
TOTAL WATTAGE:	19W	ENERGY EFFICIENT:	Yes
DIMMABLE:	Yes	LIGHTING AMPS:	.16
MATERIAL CONSTRUCTION:	Steel & Polycarbonate	VOLTAGE:	120V
ASSEMBLED DIMENSIONS:	18" H x 5" L x 2.5" D		
WEIGHT:	1.74 lbs.		
BACKPLATE DIMENSIONS:	5" H x 5" L x 1.38" D		
CANOPY/PLATE DIMENSIONS:	N/A		
GLASS/SHADE DIMENSIONS:	N/A		
GLASS/SHADE MATERIAL:	Acrylic		
GLASS/SHADE TYPE:	Opal		
GLASS/SHADE COLOR:	White		

WARRANTY:	10-Year limited warranty
UL/ETL CERTIFICATION:	ETL
WET/DRY/DAMP LISTING:	Damp
ADA COMPLIANT:	Yes
ENERGY STAR CERTIFIED:	No



TYPE:
JOB:
ORDER CODE:
APPROVALS: