

ASSEMBLY INSTRUCTION

END TABLE WITH SHELF

A Top

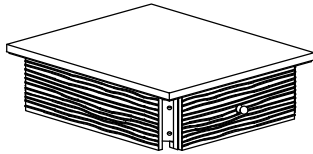

1 PC

D Connecting Metal
40 x 20 x 18mm

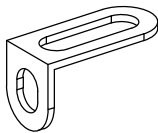

4 PCS

G Spring Washer
1/4"



16 PCS

B Leg

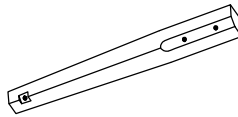

4 PCS

E Bolt
1/4" x 2"

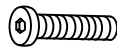

8 PCS

H Flat Washer
1/4" x 19 x 2mm



16 PCS

C Shelf

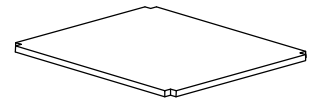

1 PC

F Bolt
1/4" x 5/8"



8 PCS

I Allen Wrench
1/4"



1 PC

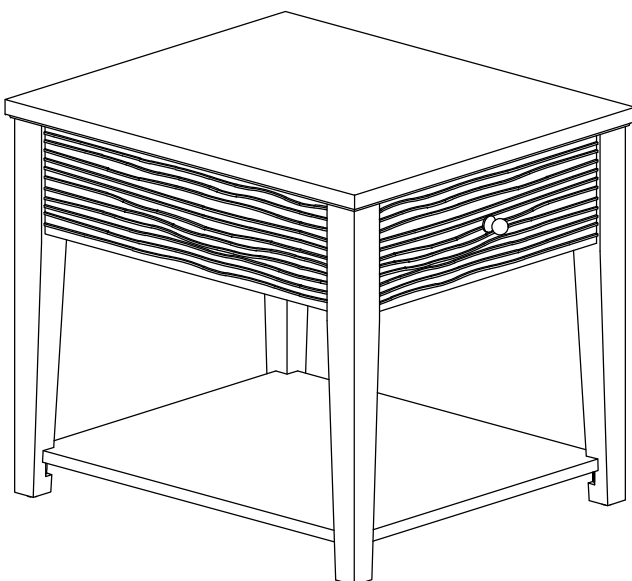

This page lists all the contents included in the box. Please take the time to identify the hardware as well as the individual components to this product. As you unpack and prepare for assembly, place the contents on a carpeted or padded area to protect them from damage.

1 Take out the drawer from the Top (A).

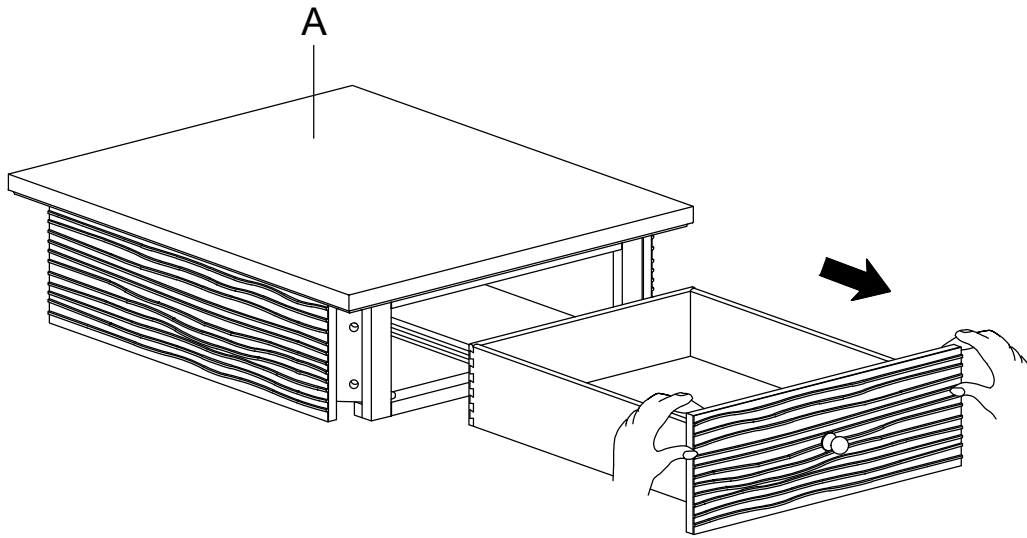

2 Attach the Leg (B) to the Top (A) using Bolt (E), Spring Washer (G) and Flat Washer (H) with Allen Wrench (I). Do not fully tighten the bolts in this step.

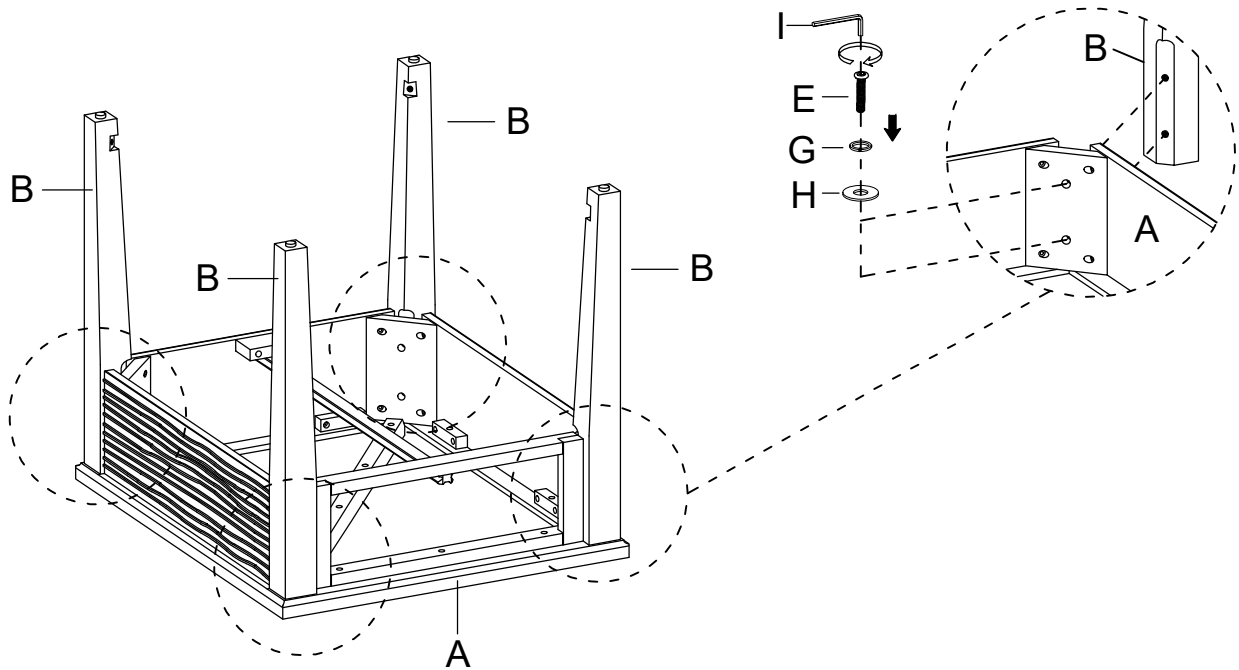

3 Attach the Shelf (C) to the Leg (B) by Connecting Metal (D) using Bolt (F), Spring Washer (G) and Flat Washer (H) with Allen Wrench (I). Fully tighten the bolts in this step.

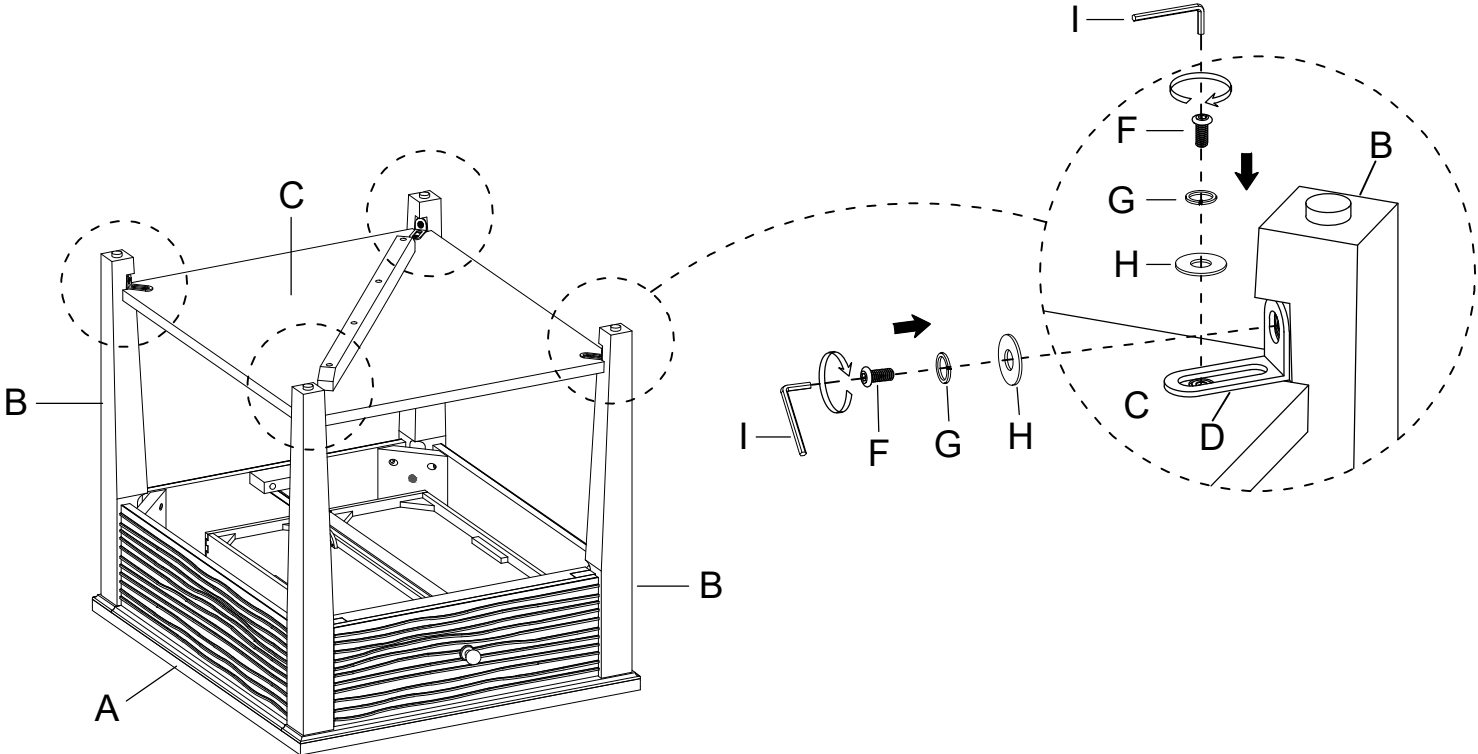

4 Put the drawer into the Top (A).

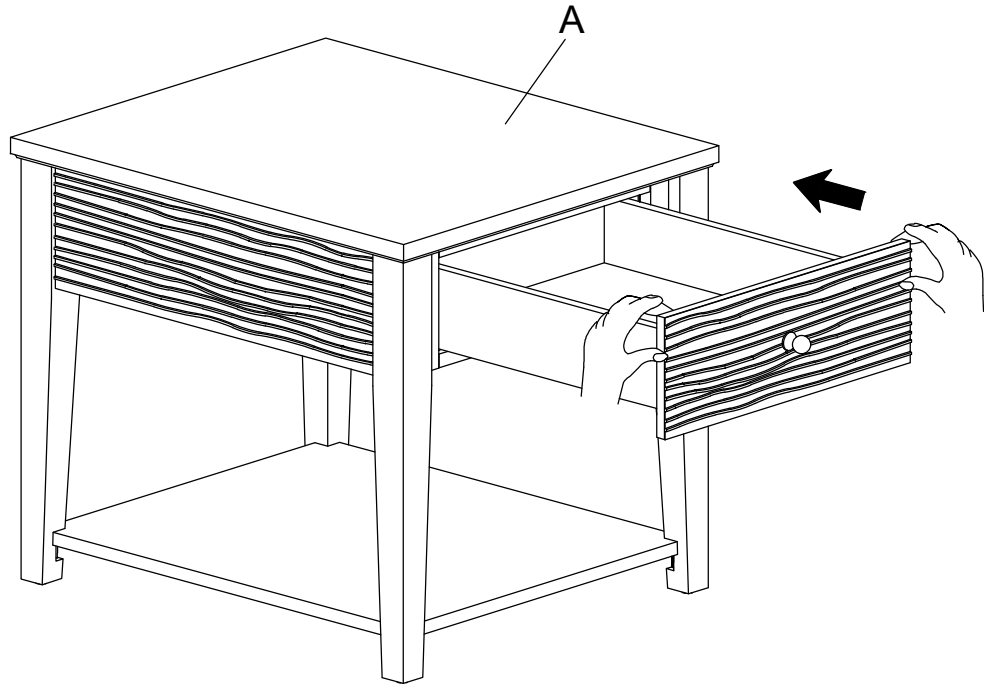

Cleaning & Care

Treat surfaces with care. Surfaces are resistant to scratches but are not scratch resistant. Clean surfaces with a dry or damp soft cloth. Do not use abrasive cleaners. Hardware may loosen over time. Periodically check that all connections are tight.