

# BLACK DIAMOND®

Project Name: \_\_\_\_\_

Location: \_\_\_\_\_

Item #: \_\_\_\_\_

Qty: \_\_\_\_\_

## Black Diamond 1 Door Narrow Depth Reach-In Refrigerator, 17.3 Cu. Ft. Capacity, in Stainless Steel

### USRF-1D/19



The Black Diamond 1 Door Narrow Depth Reach-In Refrigerator offers efficient refrigerated storage with a space-saving, slim design that fits easily into tight commercial kitchen areas. Its heavy-duty 430 series stainless steel exterior and painted aluminum interior ensure lasting durability while resisting daily wear. The self-closing solid door with recessed handle improves energy efficiency, while three adjustable wire shelves provide organized storage for ingredients such as dairy, produce, and beverages. Equipped with an electronic temperature controller and bottom-mounted compressor, it maintains consistent temperatures for optimum freshness.

### FEATURES AND CONSTRUCTION

- Offers 17.3 Cu. Ft. of interior capacity for versatile cold storage
- Narrow depth design enables placement in kitchens with limited floor space
- Constructed of heavy-duty 430 series stainless steel exterior and painted aluminum interior for long-lasting durability
- Features a self-closing solid door with recessed handle for improved sealing and ease of use
- Includes three removable, plastic-coated wire shelves for flexible organization
- Equipped with four 4-inch casters for effortless mobility and cleaning access
- Removable door gasket
- Ideal for use in restaurants, catering, bakeries, grocery stores and more
- Uses environmentally-friendly R290 refrigeration

### ELECTRIC

115V / 60Hz / 1Ph

Cord Length (Inches): 98.40"

Plug Type: NEMA 5-15P

Cord set included

NEMA 5-15P



### 3RD PARTY APPROVALS



### WARRANTY (USA / CANADA)

Two (2) Year Limited Warranty on Parts and Labor, Five (5) Year Warranty on Compressor and Evaporator

Contact us for details at 1.877.368.2797



### STORAGE CAPACITY

- Cubic Feet: 17.3 Cu. Ft.

### TEMPERATURE

- Holding Temperature (Fahrenheit): 33° - 40°

These models are designed to operate in an environment where temperature and humidity do not exceed 75°F (24°C) and 55% relative humidity



# Black Diamond 1 Door Narrow Depth Reach-In Refrigerator

USRF-1D/19

FRONT

SIDE

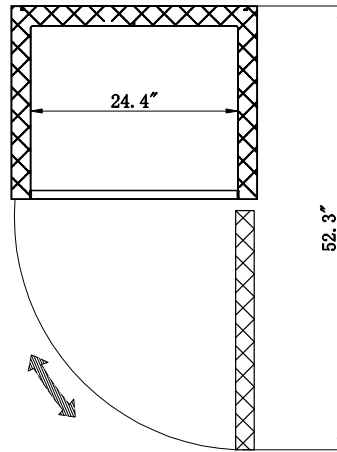
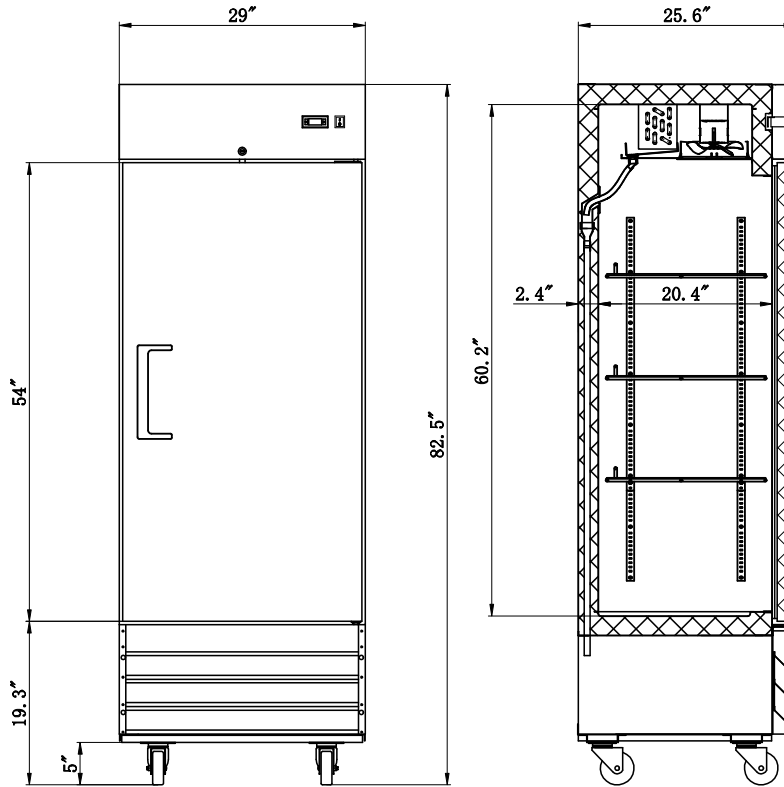

TOP

## Reach-In

Doors	Shelves	Amps	HP	Refrigerant	Assembled Dimensions (in)	Item Weight (lbs)	Shipping Weight (lbs)
1	3	3.1A	1/5	R290 2.2945	29.00" x 25.50" x 82.50"	282.0	268.0

Due to periodic changes in designs, methods, procedures, policies and regulations, the specifications contained in this document are subject to change without notice. While we exercise good faith efforts to provide information that is accurate, we are not responsible for errors or omissions in information provided or conclusions reached as a result of using the specifications. By using the information provided, the user assumes all risks in connection with such use.