

ITEM NO.	DESCRIPTION	QTY.
1	TRIANGULAR WALL SUPPORT	1
2	3/8" x 2-1/2" COTTER PIN	3
3	COTTER PIN CLIP	3
4	J-BOLTS 5/16-18 x 3-1/2"	2
5	5/16-18 HEX NUT w/LOCK WASHER	2
6	INSTRUCTION SHEET	1

CATALOG NUMBERS	DESCRIPTION	SURFACE FINISH	DIMENSION "A"	DIMENSION "B"	DIMENSION "C"
HLTSB06B	SHELF BRACKET 6" WIDE	BLACK	7.00"	7.00"	5.25"
HLTSB06G	SHELF BRACKET 6" WIDE	GRAY	7.00"	7.00"	5.25"
HLTSB12B	SHELF BRACKET 12" WIDE	BLACK	13.00"	13.00"	11.25"
HLTSB12G	SHELF BRACKET 12" WIDE	GRAY	13.00"	13.00"	11.25"
HLTSB18B	SHELF BRACKET 18" WIDE	BLACK	19.00"	19.00"	17.25"
HLTSB18G	SHELF BRACKET 18" WIDE	GRAY	19.00"	19.00"	17.25"
HLTSB24B	SHELF BRACKET 24" WIDE	BLACK	25.00"	25.00"	23.25"
HLTSB24G	SHELF BRACKET 24" WIDE	GRAY	25.00"	25.00"	23.25"

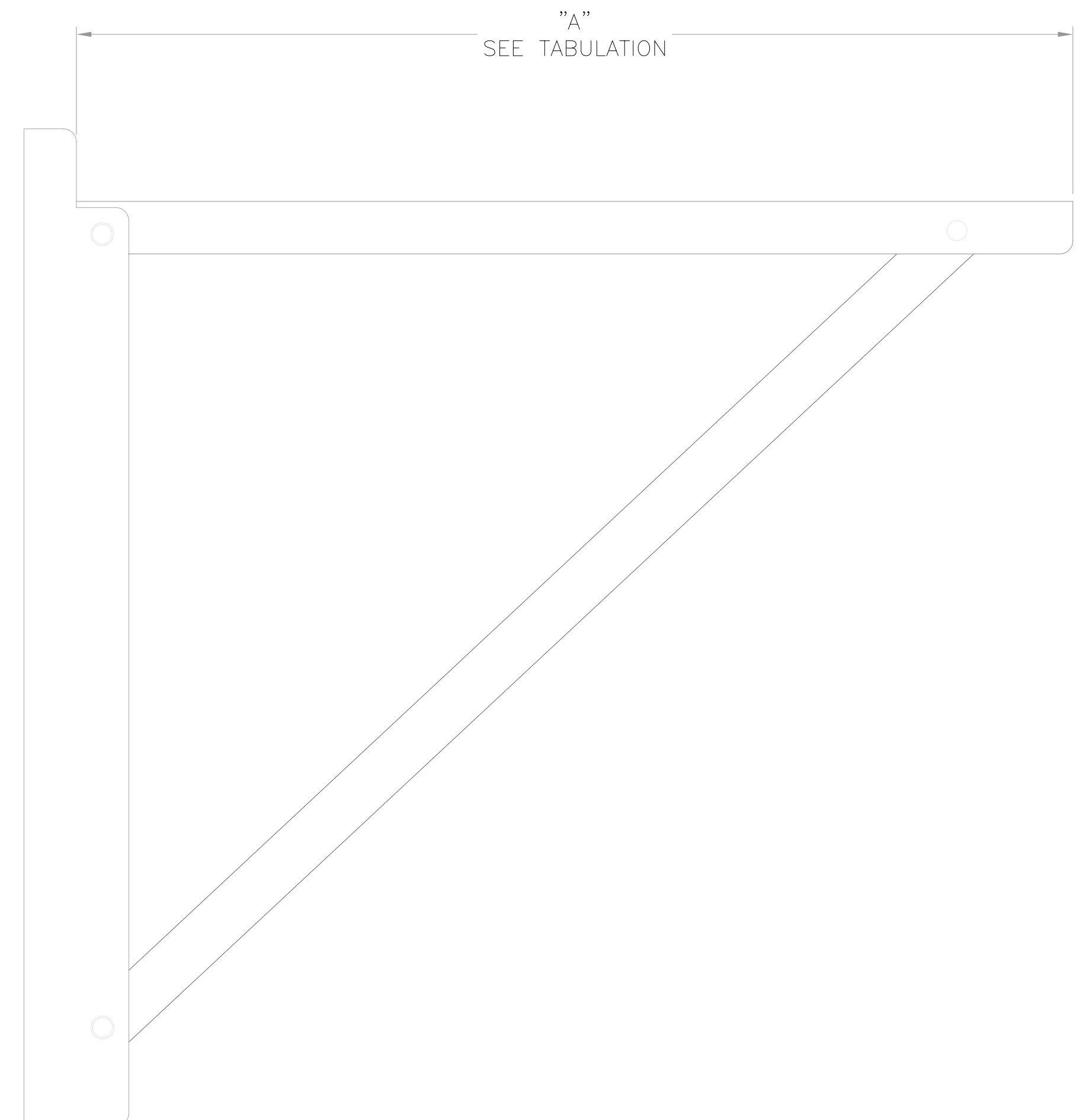
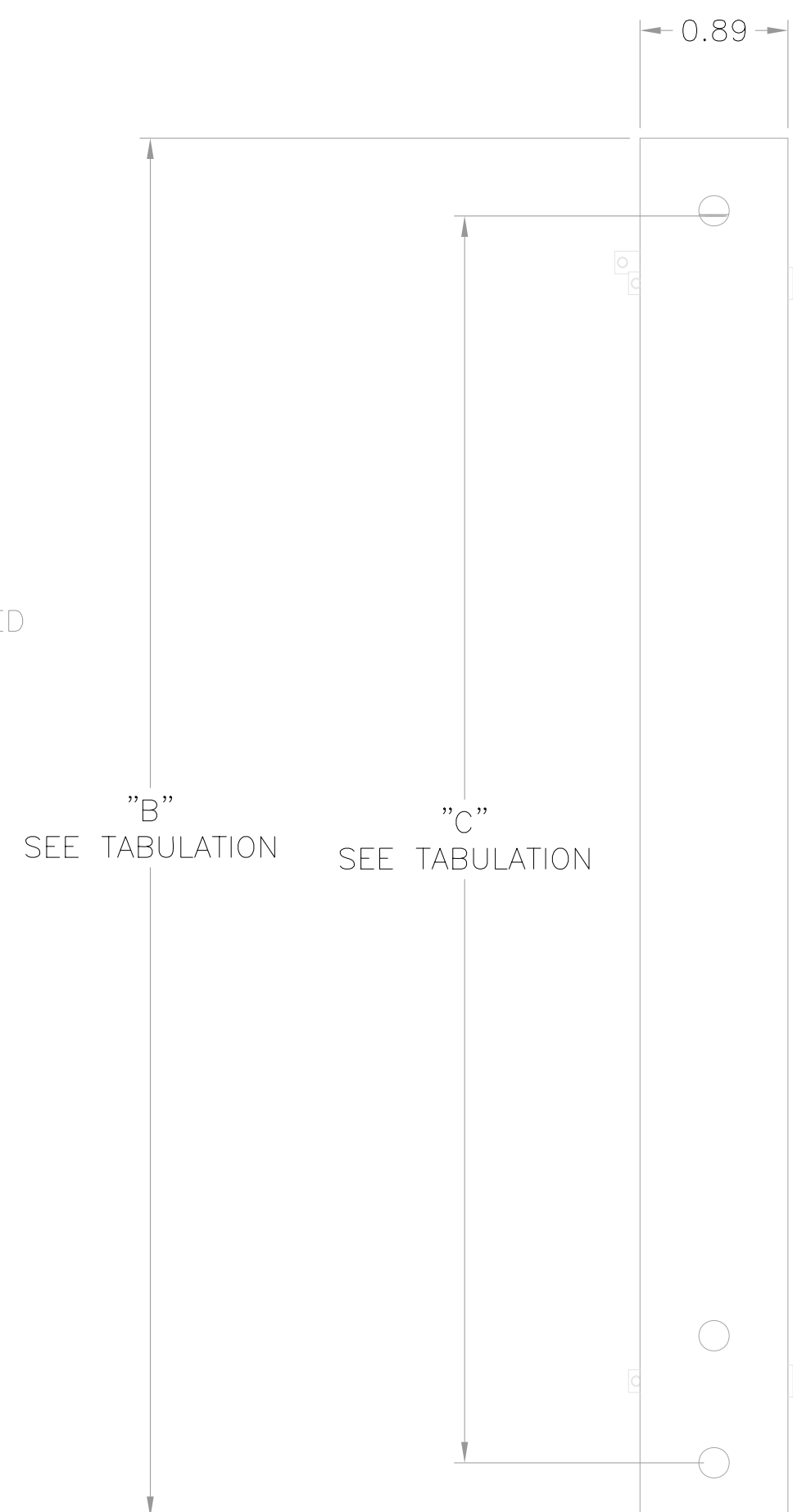
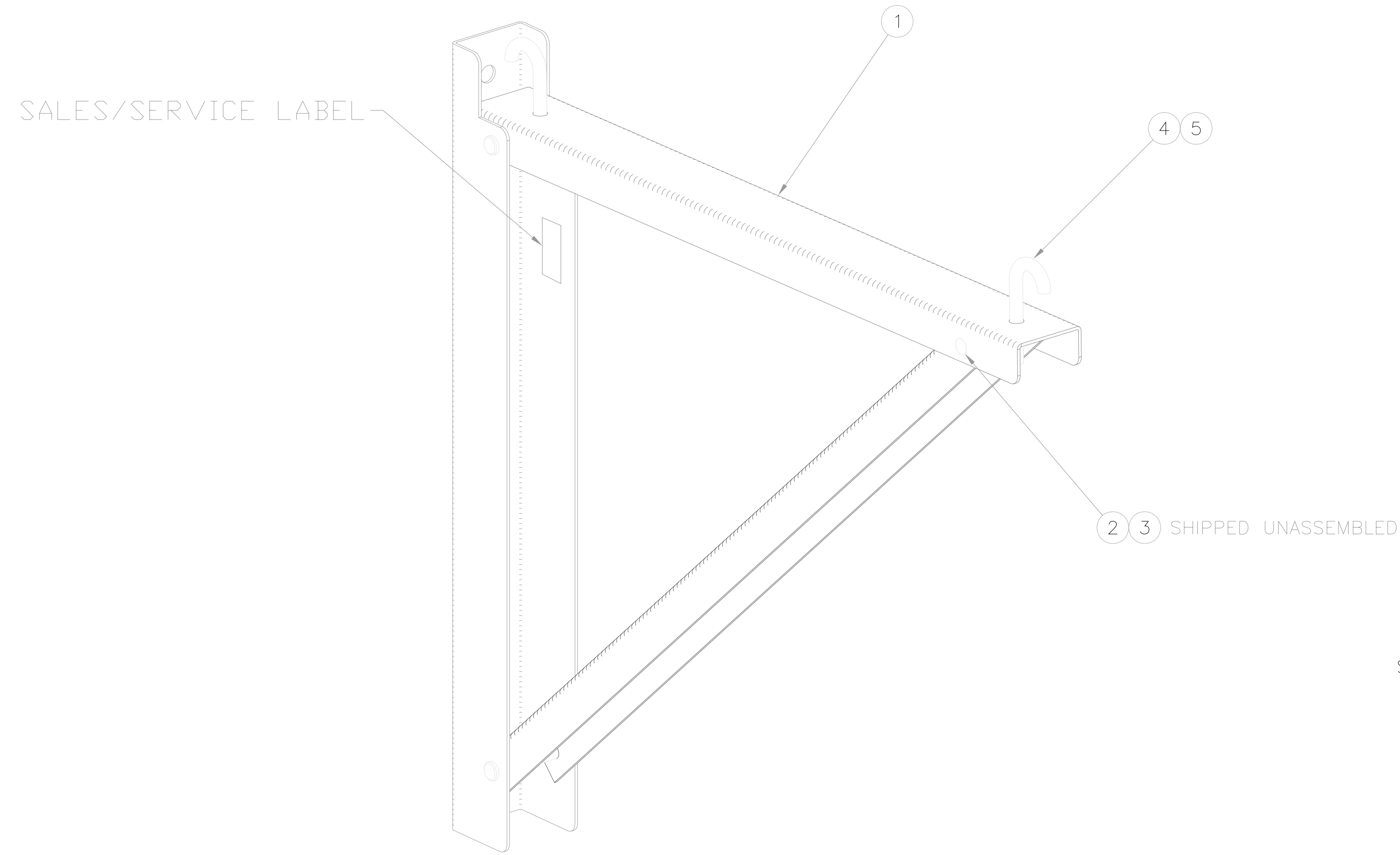
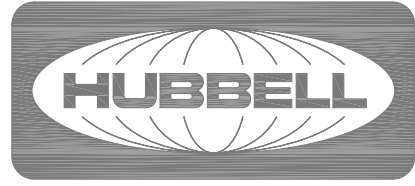

REV.	ECN	DATE	DESCRIPTION	CHG BY	APPD BY
B	16457	08/04/10	REVISED J-BOLT LENGTH	MMA	MO

Created on AUTOCAD	DIMENSIONING AND TOLERANCE PER ANSI Y14.5M-1982. UNLESS OTHERWISE SPECIFIED, DIMENSIONS ARE IN INCHES (MM). TOLERANCES .XX = ±.01 (.25) .XXX = ±.005 (.127) .XXXX = ±.0025 (.0635) ANGLE TOL ±1°		PROJECT REFERENCE:		 <b>Hubbell Premise Wiring</b> HUBBELL INCORPORATED (Delaware) 14 Lord's Hill Road, Stonington, Connecticut 06378
	IN ACCEPTING OUR DRAWINGS, BLUEPRINTS, OR SUPPORTING DOCUMENTATION FOR QUOTATION OR OTHER PURPOSES, YOU AGREE NOT TO DISCLOSE TO OTHERS THE IDEAS, INFORMATION, OR DESIGNS SHOWN HEREIN, AND THAT YOU WILL MAKE NO USE OF SAME WITHOUT PERMISSION		MATERIAL:		
			DRAWN BY: PAUL S. MAGUIRE 04/23/02		TITLE: <b>RACKS/LADDER RACKS CABLE MANAGEMENT ASSY, TRIANGLE WALL SUPPORT</b>
			CHECKED BY: M. MAROVIC ABBY 04/29/02		SIZE   DRAWING NO. <b>D   C11252</b>
		APPROVED BY: M. MAROVIC ABBY 04/29/02		SCALE: <b>1/1</b>   SHEET <b>1 OF 1</b>   REV. <b>B</b>	