







# HEKMAN®

A HOWARD MILLER COMPANY

## ASSEMBLY INSTRUCTION FOR 24961 CHEST

### HARDWARE LIST

NO.	ITEM	DESCRIPTIN	QTY.
1		JCB Bolt M6 X 20 MM	10
2		Flat washer M8X25 MM	10
3		Allen wrench	1
4		Bolt M8X20 MM	4
5		Wrench	1
6		Flat washer M6X18 MM	4

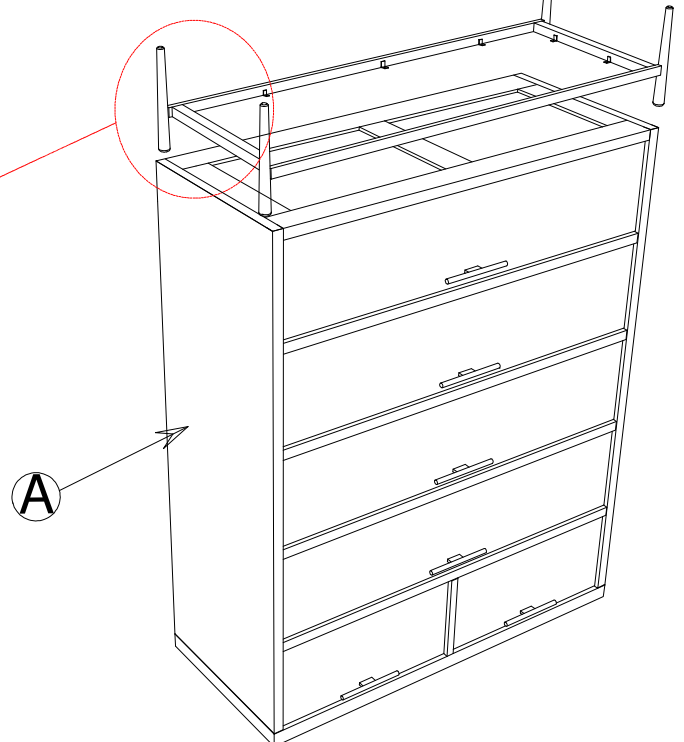
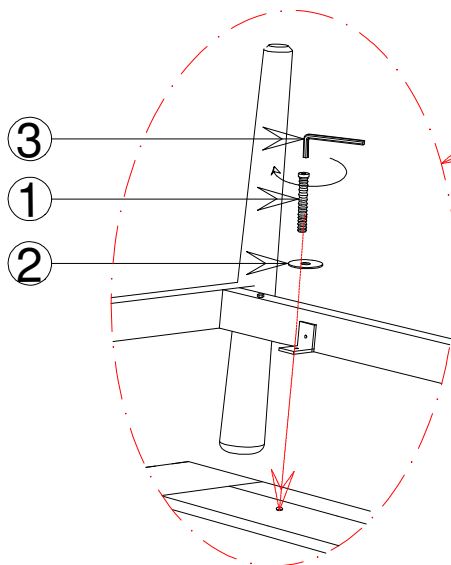
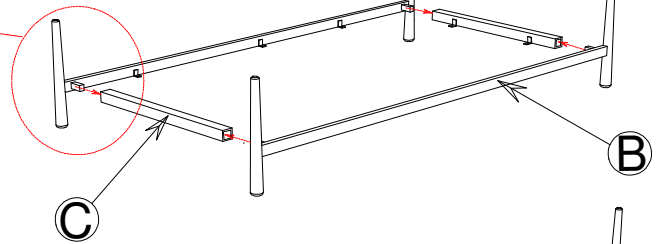
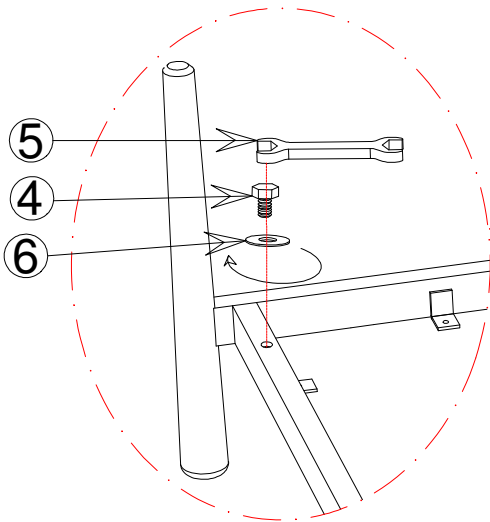
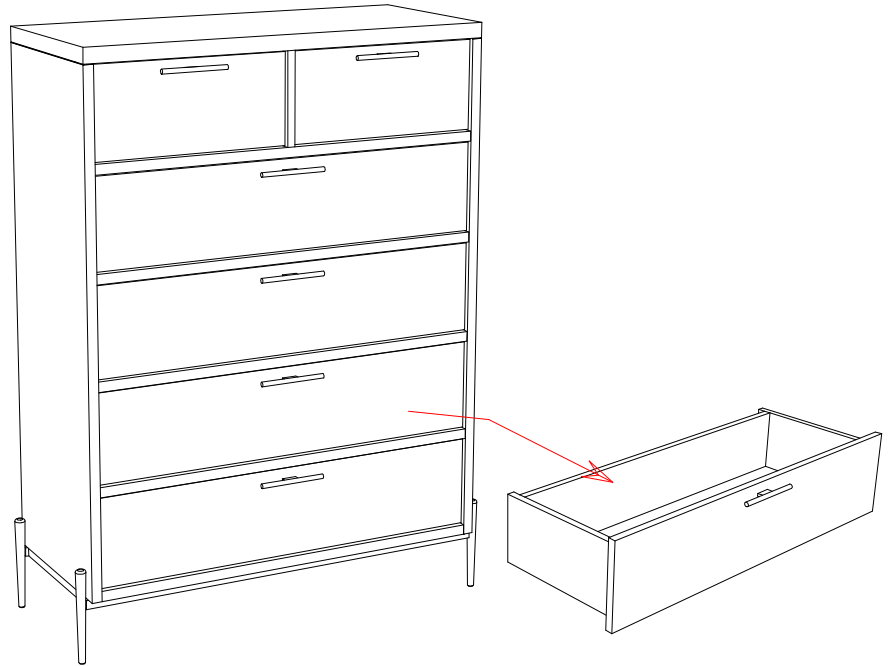

### TO ASSEMBLY :

STEP 1 : Unpack chest and remove drawers.

STEP 2 : Roll chest on its back, then on its top on a clean, soft surface.

STEP 3 : Thread the HEX. bolt(4) to iron leg(B) & iron cross bar(C). using small washers(6) tighten metal base assembly fully.

STEP 4 : Set base assembly on the upside down case and attach with bolt (1) and washer (2) using allen wrench (3).

STEP 5 : Tighten bolts in step 6 fully with allen wrench (3) & wrench (5) then carefully turn the chest upright.

STEP 6 : Install drawers.