

Product Specifications

2-Gallon EZ STOR® Container with Hinged Cover

Multiple Uses

Dry Products

Product Codes

Container: **E027**

Description: 2-gallon rectangular can

Cover: **E2DR**

Description: Dry seal, tamper-evident, hinged, EZ open & close cover with Ring Pull®

Features

Gauge: 60 mil.
 Nominal capacity: 2.0 USG / 7.6 L
 Stack performance: 140 lbs.*
 Tare weights: Body: .72 lbs. / .33 kgs.
 Cover: .20 lbs. / .09 kgs.

Note: *Ratings will be reduced with uneven load distribution.

Specifications with Cover

Dimensions: 9-3/4"L X 7-3/4"W X 9-5/8"H
 Maximum capacity: 2.11 USG / 8 L
 Tare weight: .92 lbs. / .42 kgs.

Colors

Standard: White, Natural and Clear
 Custom: Available at manufacturer's discretion

Decorating Options

Four or six color offset printing*
 Sleeve or pressure sensitive labeling
 In-Mold labeling (IML)
 Note: *Where available

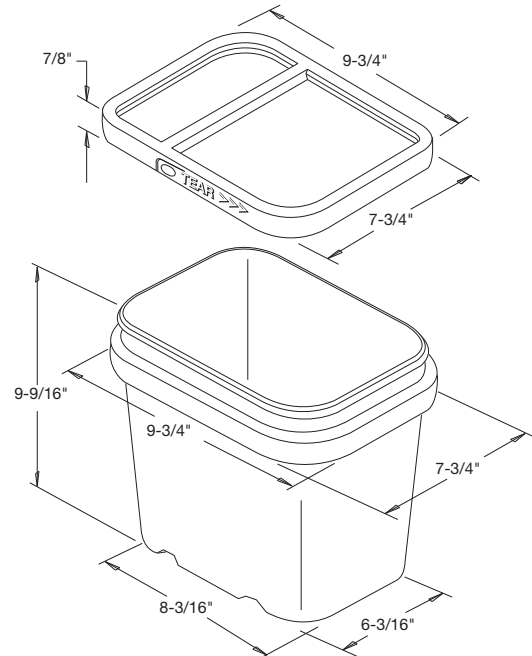

Shipping Data

	Bodies	Covers
Qty. per pallet:	400	3,000 (30 boxes of 100)*
Gross Weight (lbs./kgs.)**:	288/132	600/270
Den. (lbs./C.F./kgs./m3):	7.3/117.4	8.6/135.9
Length (in./cm.):	49.0/124.5	42/106.7
Width (in./cm.):	40.0/101.6	37/94
Height (in./cm.):	35.0/88.9	78/198.1
Estimated truckload quantity of 17,600 bodies and covers***		

Filled Containers

100 (25 per layer / 4 layers high)
 Pallet height: 43-1/4"

Notes: *Bulk pack of 1200 is also available
 **Weight does not include pallet / packaging
 ***Truckload quantity based on 48' trailer

Materials

FDA approved materials
 Resin: Body: High Density Polyethylene (HDPE)
 or Clear Polypropylene
 Cover: Polypropylene (PP)
 MSDS Sheets available upon request

Optional Carrying Handle

DISCLAIMER
 THIS INFORMATION IS PROVIDED AS A GENERAL GUIDE, INCLUDING DIMENSIONS. IT IS THE CUSTOMER'S RESPONSIBILITIES TO SELECT THE PROPER CONTAINER FOR PRODUCT AND APPLICATION COMPATIBILITY.

DISTRIBUTED BY:



REF NO.:

DWG30563

DESCRIPTION: HDPE EZ Stor Cover for 2 Gallon Pails
 (No Gasket)