

Installation / Use Manual

Original Instructions

Model: LZS8WSS2K Bottle Filling Station & Cooler



Description

Combination Refrigerated Drinking Fountain (Cooler) and Bottle Filling Station delivers chilled, clean potable drinking water. Top Bottle Filling section offer touchless activation to dispense water for bottles. While the bottom Water Cooler section, which houses the refrigeration and filtration systems, delivers a steady stream of water for direct drinking at the press of front and sidebars.

Ratings

- Electrical: 230Vac, 50Hz, (See Nameplate for Amperage), 1 phase.
- Ambient Air Temperature: 10-38 °C (50-100.4 °F).
- Water Pressure: 20-100 psig (0.14-0.69 MPa).
- Maximum Water Temperature: 90 °F (32 °C).
- Refrigerant: HFC-R134a
- Ingress Protection: IP2x
- For Indoor Commercial Use only.
- Water Inlet: 3/8" O.D. unplated copper tube.
- Waste Water Outlet: 1-1/4" O.D. tube

Definitions

DANGER – Indicates death or serious injury will result if proper precautions are not taken.

WARNING – Indicates death, serious injury or property damage can result if proper precautions are not taken.

CAUTION – Indicates some injury or property damage may result if proper precautions are not taken.

Authorized Service Personnel – Factory trained personnel or personnel having working knowledge of electrical, plumbing and machine (appliance) maintenance procedures.

Safety

DANGER

- Please read these instructions completely before starting the installation or performing any service. Failure to follow the instructions and safety precautions in this manual can result in serious injury or death.
- After installation, keep these instructions in a safe location for future reference.
- Electric supply must be identical in voltage, cycle, and phase to that specified on nameplate.
- Electrical supply must have Ground Fault Circuit Interrupter (GFCI) protection.
- A means for disconnecting electrical supply to the unit must be incorporated in the fixed wiring in accordance with wiring rules. This is to allow electrical disconnection of the unit from electrical supply after installation.

WARNING

- For use with clean, clear potable drinking water only. Do not use with water that is microbiologically unsafe or of unknown quality without adequate disinfection before the system.
- Installation and connection to water and electrical mains must be in compliance with local and national laws.
- All Installation and Service work must be performed by an authorized service personnel.

CAUTION

- This appliance can be used by children aged from 8 years and above and persons with reduced physical, sensory, or mental capabilities or lack of experience and knowledge if they have been given supervision or instructions concerning use of the appliance in a safe way and understand the hazards involved. Children shall not play with the appliance. Cleaning and user maintenance shall not be made by children without supervision.
- To prevent a metallic taste or increased metal content in the water due to an electrolysis process caused by electrical feedback from the grounding of electrical equipment to water supply and water waste mains, connect to these mains using non-conductive materials. The provided Filter meets this requirement.

Installation

For correct and safe installation, please read these instructions completely.

DANGER

- All Installation work must be performed by an authorized service personnel.
- Disconnect electrical supply serving the Installation area to reduce risk of electrocution.
- Unit not suitable for installations where water jets could be used.

WARNING

- Shut off water supply serving the Installation area to reduce risk of water damage.
- Ensure proper ventilation by maintaining clearance from cabinet louvers to wall on each side of Cooler as specified in Rough-In.
- Never wire compressor directly to electrical supply.
- Thoroughly flush all water lines and fittings of all foreign matter before connecting to Cooler.
- Warranty is void if Installation is not made in accordance with current Manufacturing instructions.

CAUTION

- Hose-sets are not to be used for connecting to water mains.
- If inlet pressure is above 100 psig (0.69 MPa), a pressure regulator must be installed in water supply line. Any damage caused by reason of connecting this product to water supply line pressure outside it's rated pressure, is not covered by warranty.
- Tools/Items required but not provided.
 - o Water Shut-off Valve with 3/8" (9.5mm) compression outlet.
 - o Waste Trap (non-metallic)
 - o Safety Glasses
 - o Protective Gloves
 - o Hex drives.
 - o Fasteners for wall type.

Installation: Cooler Mounting

1. Remove Hanger Bracket fastened to back of cooler by removing one (1) screw.
2. Mount Hanger Bracket as shown in Figure 1.
 - NOTE: Hanger Bracket MUST be supported securely. Add fixture support carrier if wall will not provide adequate support. Anchor hanger securely to wall using all six (6) 9/32" (7mm) diameter mounting holes.
 - IMPORTANT: 5-7/8 inches (150mm) dimension from wall to centerline of trap must be maintained for proper fit.
3. Hang Cooler on the Hanger Bracket. Be certain the Hanger Bracket is engaged properly in the slots on the cooler back as shown in Figure 1,
4. Remove the four (4) screws holding the lower front panel at the bottom of cooler. Remove the front panel by pulling straight down and set aside.

Installation: Water Line connection

1. Ensure Mains Water Supply has Water Shut-off Valve with 3/8" (9.5mm) compression outlet.
 2. Connect loose end of supplied 3/8" (9.5mm) unplated copper tube to Water Shut-off Valve. Other end of tube should be connected to inlet of Filter head. If not connected, simply insert into inlet fitting on Filter head until positive stop – approximately 3/4" (19mm). Then tighten locknut handtight to seal.
 - NOTE: If 3/8" (9.5mm) copper tube must be cut for proper fit, remove all burrs from the outside of tube and re-flush before use.
 3. Install filter cartridge. Remove filter from carton, remove protective cap, and attach filter to filter head by firmly inserting into head and rotating filter clockwise.
- **IMPORTANT: DO NOT TURN ON WATER BEFORE INSTALLING BOTTLE FILLER**

Installation: Waste Line connection

1. Install waste trap. Remove the slip nut and gasket from the waste trap and install them on the cooler waste line making sure that the end of the waste line fits into the waste trap. Assemble the slip nut and gasket to the waste trap and tighten securely.
 - IMPORTANT: If it is necessary to cut the drain, loosen the screw at the black rubber boot and remove tube, check for leaks after reassembly.
2. It is recommended that the waste trap be insulated to avoid excessive condensation due to chilled water running through the waste trap.
3. Turn on building water supply and open Water Shut-off Valve. Check all connections for leaks and correct any found.

Installation: Electrical connection

1. Rotate fan to insure proper clearance and free fan action.
2. Connect modular (C-13) end of International Power Cord Set (sold separately) into Power Inlet on Cooler and ensure plug-end reaches electrical outlet. Do not plug into electrical outlet!

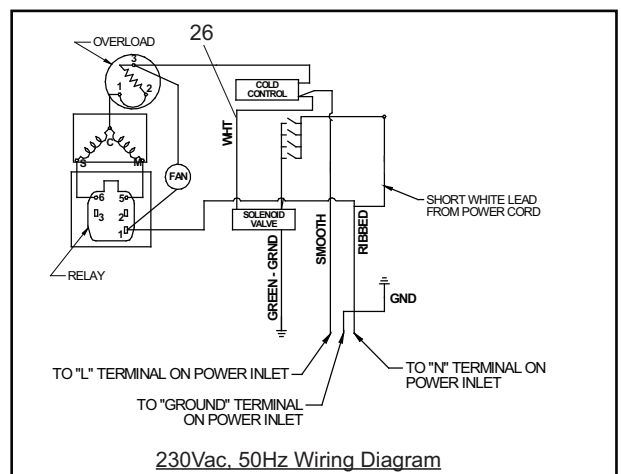

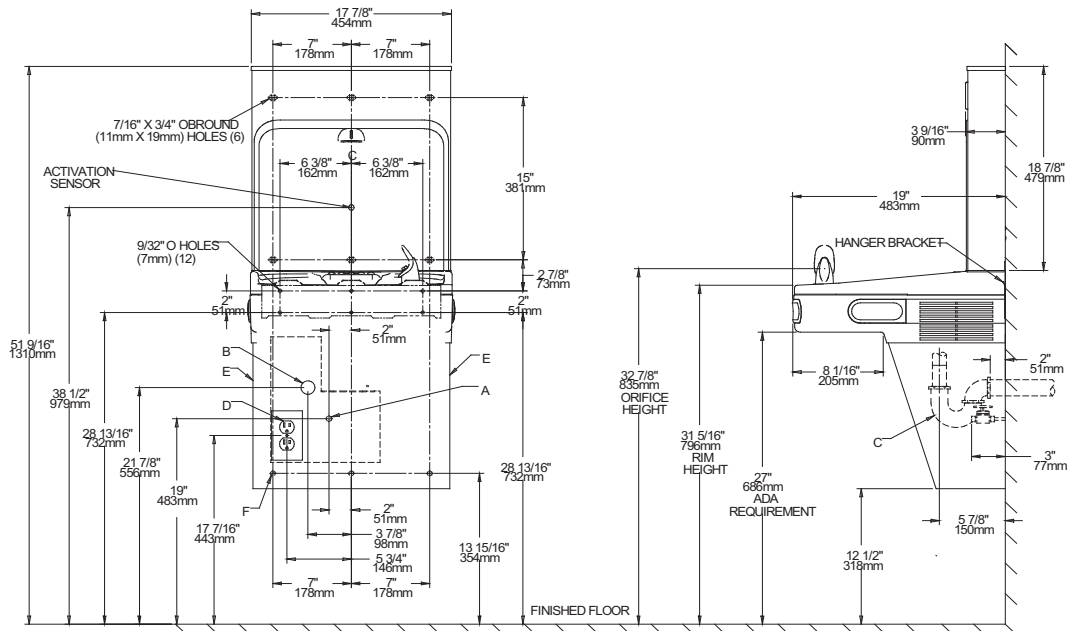
Rough-In: LZS8WSS2K

- A = Water Mains Supply, 3/8" (9.5mm) O.D. compression outlet of Shut-off Valve (not provided) to be 3" (76mm) from Wall.
 Maximum Water Supply Line Pressure: 105 Psi (0.73 MPa).
 B = Waste Outlet, 1-1/4" (31.8mm) O.D. Drain tube terminating 2" (51mm) maximum from wall.
 C = 1-1/4" (31.8mm) Trap (not provided).
 D = Electrical Mains Supply Outlet, 3-wire in Recessed Box. Must have Ground Fault Circuit Interrupter (GFCI) protection.
 E = Ensure proper ventilation by maintaining 6" (152mm) minimum clearance from cabinet louvers to wall.
 F = 7/16" (11mm) Bolt holes for fastening unit to wall.

Figure 1

Installation: Bottle Filler Mounting

- Remove two (2) mounting screws with 5/32" Allen wrench holding top cover to Bottle Filler. Remove top cover. Note: do not discard mounting screws; they will be needed to reinstall top cover. (See Fig. 3)
- Remove wall mounting plate from Bottle Filler. Place wall plate against wall on top of basin. Center the wall plate side to side with the basin. Mark the six (6) mounting holes with a pencil (See Fig. 1).
- Remove wall mounting plate from wall. NOTE: Mounting plate MUST be supported securely. Add fixture support carrier if wall will not provide adequate support.
- Install wall mounting plate to wall using six (6) 7/16" oval mounting holes (mounting bolts not included) (See Fig. 2). Use appropriate fasteners for your wall type.
- Feed 3/8" water line through hole in tower/basin gasket (See Fig 4).
- Install gasket on the bottom of bottle filler tower by pushing detents into the place (See Fig 5).
- Feed modular (C-13) end of International Power Cord Set up through basin hole and hole in gasket, and connect to Power Inlet on Bottle Filler. Do not plug into electrical outlet.
- Lay Bottle Filler on water cooler basin and cut insulation from tube even with bottom of gasket, remove this insulation from the 3/8" tube, but do not discard. Feed the waterline through the hole on top of water cooler. NOTE: To prevent scratching the basin, place a towel or soft cloth over the entire basin when working above it.

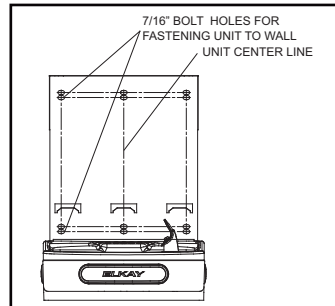

Figure 2

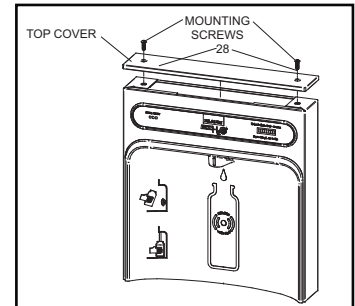

Figure 3

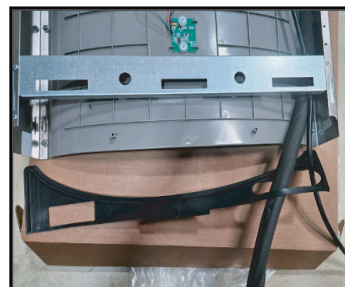

Figure 4



Figure 5

12. With the power cord, wire(s), and waterline through hole on top of water cooler place Bottle Filler on the three (3) angled tabs protruding from the wall mounting plate, installed on wall (See Fig. 6). Make sure round boss in gasket fits in hole of basin.
13. Once Bottle Filler is installed on wall plate tabs, water line, wire(s) and power cord are installed properly, push top of Bottle Filler toward wall and line up top cover two (2) holes.
14. Reinstall Top Cover on Bottle Filler (See Fig. 3) with two mounting screws from step 1 above. Caution: do not over tighten screws.
15. Install remaining tube insulation to the water line from bottle filler, connect Bottle Filler waterline inside of the water cooler by connecting the 3/8" water line to the tee.
16. Install filter cartridge, remove filter from carton, remove protective cap, attach filter to filter head by firmly inserting into head and rotating filter clockwise. NOTE: If existing plumbing rough in locations (Drain, Water In, and Electric Supply) do not allow the filter to be mounted inside the cooler cabinet, the filter can be installed horizontally below the unit. A retrofit kit is available to mount the filter beneath the cooler.
17. Turn water supply on and inspect for leaks. Fix all leaks before continuing.
18. Once unit has been inspected for leaks and any leaks found corrected, connect plug end of International Cord Sets from the Cooler and Bottle Filler into electrical outlet. Be sure to reinstall fuse to the circuit or switch the circuit breaker back to the "ON" position.
19. Once power is applied to Bottle Filler, the GREEN LED light should illuminate showing good filter status along with the LCD Bottle Counter.
20. Verify proper dispensing by placing cup, hand, or any opaque object in front of sensor area and verify water dispenses. Note: the first initial dispenses might have air in line which may cause a sputter. This will be eliminated once all air is purged from the line.
21. Once unit tests out, install Lower Panel back on water cooler(s). Units are now ready for use.

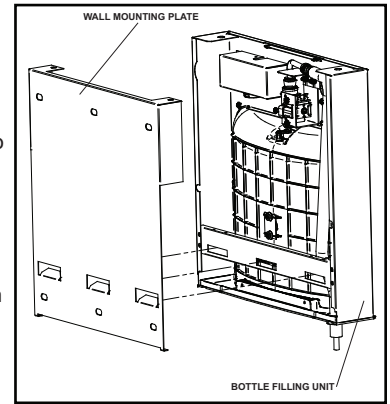
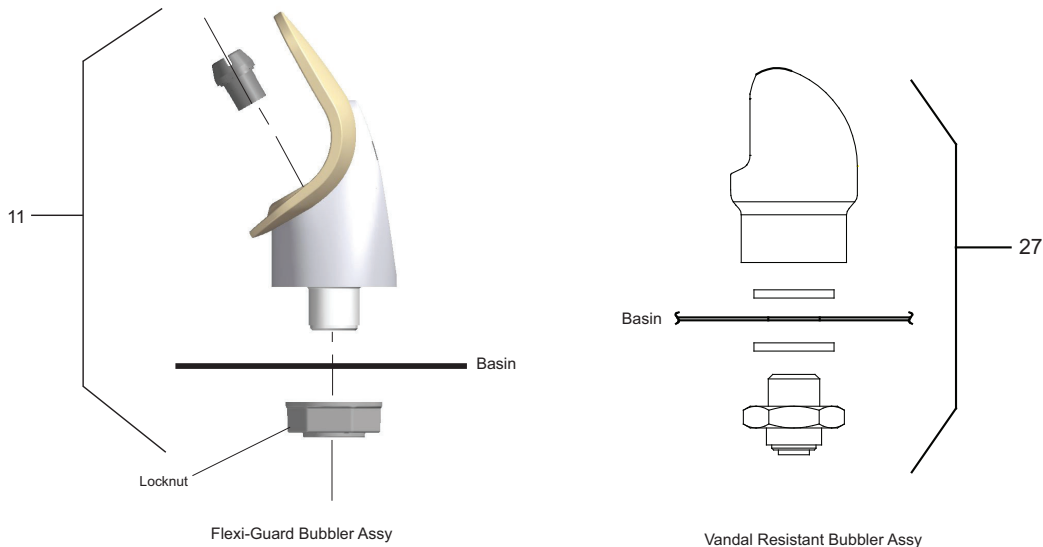

Figure 6

Operation: Start-Up

1. Turn on the building water supply and check all connections for leaks.
2. Ensure unit is plugged into electrical supply. Unit must have electrical power to have water flow.
3. **WARNING:** Exposed electrically energized components. Use extreme caution.
 3. Purge air from all water lines by:
 - Depressing button or front push bar of cooler/fountain.
 - Placing cup, hand, or any opaque object in front of Bottle Filler sensor area to dispense water.
 - NOTE: Steady stream of water assures all air is removed.
4. Recheck all water and drain connections with water flowing through system.
5. Replace the lower front panel ensuring that the top metal edges are secured inside of the upper shroud. Replace all four (4) screws previously removed.



Operation: Bottle Filler Control Board Set-Up BF11-BF12

VERIFY CONTROL BOARD SOFTWARE

- 1) To verify the software program of the control board the unit will need to be shut down and restarted. The chiller (if present) does not need to be shut down and restarted.
- 2) The units lower panel must be open to access the power cord and wall outlet.
- 3) Shut down the unit by unplugging the power cord from the wall outlet.
- 4) Restart the unit by plugging the power cord back into the wall outlet.
- 5) Upon start up, the bottle count display will show the software designation of BF11 or BF12.

ACCESSING THE PROGRAMMING BUTTON

- 1) To access the program button, remove the top cover of the bottle-filler. Remove the two (2) screws holding top cover to bottle-filler with a 5/32" allen wrench. Remove top cover. Do not discard mounting screws, they will be needed to reinstall the top cover after programming operations are completed. The programming button is located at the top right side of the unit on the control board.

NOTE: When applicable, there is also an alternate reset button located on the lower part of the water cooler. After removing the bottom cover, the reset button will be located on the left side of the cooler, mounted on the side panel support.

RESET THE FILTER MONITOR

- 1) Instructions apply to filtered units only.
- 2) Depress the program button for approximately 2 seconds until the display changes then release. The display will change and scroll through two messages:
"RST FLTR" – Reset Filter Monitor
"SETTINGS" – System Settings Sub Menu
If the program button is not pushed again the display will scroll through the two messages above for three cycles and then default back to bottle count and be back in run mode.
- 3) When the display changes to "RST FLTR", depress the button again. The display will change to show "FLTR =". Depress the button again and the display will show "FLTR =0"
- 4) The Green LED should be illuminated indicating that the visual filter monitor has been reset.

SETTING RANGE OF THE IR SENSOR WHERE APPLICABLE

- 1) Depress the program button for approximately 2 seconds until the display changes then release. The display will change and scroll through two messages:
"RST FLTR" – Reset Filter Status LED
"SETTINGS" – System Settings Sub Menu
If the program button is not pushed again the display will scroll through the two messages above for three cycles and then default back to bottle count and be back in run mode.
- 2) When the display changes to "SETTINGS", depress the button again. The display will change to show
"RNG SET" - Range set for IR sensor.
"UNIT TYP" - Type of unit (REFRIG or NON-RFRG)
"FLT SIZE" - Select filter capacity
"RST BCNT" - Reset bottle count
- 3) When display shows "RNG SET" push program button once the display will show current value (can be 1 – 10) e.g. "RNG = 3".
- 4) Once display shows current value push the program button to scroll through value of 1 – 10. Select the desired range setting, "1" being closest to sensor and "10" being farthest away.
- 5) Once range is selected allow approximately 4 seconds to pass and then the display will go back to bottle counter and be in run mode.
- 6) Test bottle filler by placing bottle or hand in front of sensor to make sure water is dispensed.

SETTING UNIT TYPE

- 1) Depress the program button for approximately 2 seconds until the display changes then release. The display will change and scroll through two messages:
"RST FLTR" – Reset Filter Status LED
"SETTINGS" – System Settings Sub Menu
If the program button is not pushed again the display will scroll through the two messages above for three cycles and then default back to bottle count and be back in run mode.

Continued from below:

- 2) When the display changes to "SETTINGS", depress the button again.
The display will change to show
"RNG SET" - Range set for IR sensor.
"UNIT TYP" - Type of unit (REFRIG or NON-RFRG)
"FLT SIZE" - Select filter capacity
"RST BCNT" - Reset bottle count
- 3) When display shows "UNIT TYPE" push program button once the display will show current value. Can be REFRIG or NON-RFRG
- 4) Push button once to change value. Once value is selected the display will show the new value. (Can be REFRIG or NON-RFRG)
"REFRIG" - stands for refrigerated product. In this setting the flow rate is estimated at 1.0 gallon per minute.
"NON-RFRG" - stands for nonrefrigerated product. In this setting the flow rate is estimated at 1.5 gallons per minute. Both "REFRIG" and "NON-RFRG" simulate 1 bottle equal to 20 oz.
- 5) Allow approximately 4 seconds to pass and the display will return to bottle counter and be in run mode.

RESETTING BOTTLE COUNT

- 1) Depress the program button for approximately 2 seconds until the display changes then release. The display will change and scroll through two messages:
"RST FLTR" – Reset Filter Status LED
"SETTINGS" – System Settings Sub Menu
If the program button is not pushed again the display will scroll through the two messages above for three cycles and then default back to bottle count and be back in run mode.
- 2) When the display changes to "SETTINGS", depress the button again.
The display will change to show:
"RNG SET"- Range set for IR sensor.
"UNIT TYP" - Type of unit (REFRIG or NON-RFRG)
"FLT SIZE" - Select filter capacity
"RST BCNT" - Reset bottle count
If the button is not pushed again the display will scroll through the four messages above for three cycles and return to run mode.
- 3) When display shows "RST BCNT" push program button once the display will show current value, e.g. "0033183".
- 4) Once display shows current value push the program button once more to reset back to 0. The display will show BTLCT = 0 for approximately 2 seconds and then return to run mode showing 00000000 bottles.
NOTE: Once the bottle count is reset to zero there is no way to return to the previous bottle count.
- 5) Testing the bottle counter:
REFRIG units: Place bottle or hand in front of sensor for approximately 9 seconds to see bottle counter count 00000001,
(This is based on filling a 20 oz. bottle).
NON-RFRG units: Place bottle or hand in front of sensor for approximately 6 seconds to see bottle counter count 00000001,
(This is based on filling a 20 oz bottle).

SETTING FILTER CAPACITY

- 1) Depress the program button for approximately 2 seconds until the display changes then release. The display will change and scroll through two messages:
"RST FLTR" – Reset Filter Status LED
"SETTINGS" – System Settings Sub Menu
If the program button is not pushed again the display will scroll through the two messages above for three cycles and then default back to bottle count and be back in run mode.
- 2) When the display changes to "SETTINGS", depress the button again.
The display will change to show:
"RNG SET"- Range set for IR sensor.
"UNIT TYP" - Type of unit (REFRIG or NON-RFRG)
"FLT SIZE" - Select filter capacity
"RST BCNT" - Reset bottle count
If the button is not pushed again the display will scroll through the four messages above for three cycles and return to run mode.
- 3) When display shows "FLT SIZE" push program button once. The display will show current value. Can be 3000GAL or 6000GAL.
- 4) Push program button again to display the desired "FLT SIZE".
- 5) Allow approximately 4 seconds to pass and the display will return to bottle counter and be in run mode.

Note: Danger! Electrical Shock Hazard. Disconnect Power Before Service Unit.**Service**

For proper and safe servicing, please read these instructions completely.

DANGER

- All Service and Maintenance must be performed by an authorized service personnel.
- Disconnect electrical supply to the unit before any service work to reduce risk of electrocution.
- Shut off water supply serving the unit before any service work to reduce risk of water damage.

CAUTION

- Tools/Items required but not provided, for Servicing:
 - o Safety Glasses
 - o Protective gloves
 - o Hex drives.

Service: Adjustments

1. **Temperature Control:** Factory set for 50°F ± 5° (10°C ± 5°) water under normal conditions. To adjust water temperature, turn screw on Item No. 13 clockwise for colder, counter clockwise for warmer.
2. **Water Stream Height:** Stream height is factory set at 35 psig (0.24 MPa). If supply pressure varies greatly from this, adjust screw located on the right knee clearance area side at bottom of the switch shroud. Clockwise adjustment will raise stream and Counterclockwise adjustment will lower stream. For best adjustment, stream should hit basin approximately 6-1/2" (165mm) from bubbler on the downward slope of the basin. Maximum Water Supply Line Pressure: 105 PSI (0.73 Mpa).
3. **Water coming out of Bubbler continuously:** When this occurs at the end of the compressor cycle, turn the cold control warmer (counterclockwise) ¼ turn.

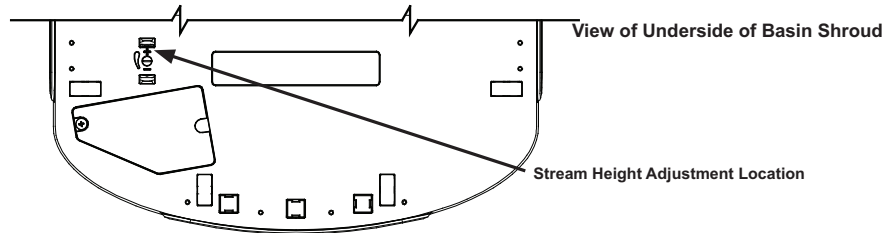
**Service: Inspection/Cleaning**

- Inspect Bottle Filler and Cooler twice each year for proper operation and performance.
 - Inspection of the unit will require disconnecting electrical supply, removal of panels, etc. and reassembly and return to service practices.
1. **Cleaning:** Warm, soapy water or mild household cleaning products can be used to clean the exterior panels. Extra caution should be used to clean the mirror finished stainless steel panels. They can be easily scratched and should only be cleaned with mild soap and water or Windex glass cleaner and a clean, soft cloth. Use of harsh chemicals or petroleum based or abrasive cleaners will void the warranty.
 2. **Bubbler:** Mineral deposits on the orifice can cause water flow to spurt or not regulate. Mineral deposits may be removed from the orifice with a small round file not over 1/8" (3 mm) diameter or small diameter wire.
 - CAUTION: DO NOT file or cut orifice material. Care must be taken not to damage the orifice(s)
 3. **Condenser Fan Motor:** Confirm condenser fan turns freely. If the condenser fan does not spin freely, have an authorized service personnel replace.
 4. **Ventilation:** Cabinet louvers and condenser fins should be periodically cleaned with a brush, air hose or vacuum cleaner. Cleaning should be done twice each year or more frequently if needed due to environment. Excess dirt or poor ventilation can cause no cold water and compressor cycling on the compressor overload protector.
 5. **Water Flow:** Confirm proper water flow. If water flow is slow, inspect filter or inline strainer for restriction. Replace filter cartridge if required. Disassemble inline strainer and clean if required.
 6. **Lubrication:** Motors are lifetime lubricated.
 7. **Actuation of Quick Connect Water Fittings:** Cooler is provided with lead-free connectors which utilize o-ring water seal. To remove tubing from the fitting, relieve water pressure, push in on the gray collar before pulling on the tubing. To insert tubing, push tube straight into fitting until it reaches a positive stop, approximately 3/4" (19mm).

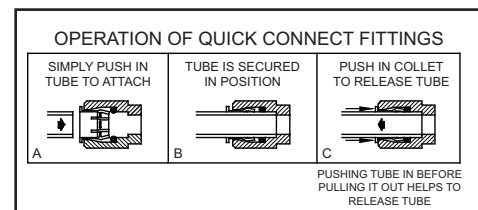

Service: Inspection/Replacement

- Inspect Bottle Filler and Cooler twice each year for proper operation and performance.
 - Inspection of the unit will require disconnecting electrical supply, removal of panels, etc. and reassembly and return to service practices.
1. **Lower Front Panel and Upper Shroud:** To access the refrigeration system and plumbing connections, remove four (4) screws from bottom of cooler to remove the lower front shroud. To remove the upper shroud for access to the pushbars, regulator, solenoid valve or other components located in the top of the unit, remove lower shroud, disconnect drain, remove four screws from tabs along lower edge of upper shroud, unplug two wires and water tube.
 2. **Bubbler:** To remove the bubbler, first disconnect the electrical supply. The underside of the bubbler can be reached through the access panel on the underside of the upper shroud. Remove the access panel by removing the retaining screw. To remove the bubbler, loosen locknut from the underside of the bubbler and remove the tubing from the quick connect fitting (see above). When installing replacement bubbler and pedestal, tighten locknut only to hold parts snug in position. **Do Not Overtighten.** After servicing, replace the lower front panel and four (4) screws.
 3. **Switches Behind the Push Bar:** The regulator in an EZ cooler is always held fully open by the use of a single regulator nut. Water is not dispensed until the pushbar is depressed to activate a switch which then opens a solenoid valve. When installing the regulator nut, the regulator spring must be depressed while turning the nut.
To remove sidebars, from the inside compress the flared tabs and pull out careful. To reinstall side pushbars, the front of the pushbar is inserted first. While keeping the switch depressed, snap the rear of the pushbar into position.
 4. **Cleaning In-Line Strainer:** Unscrew the cap of the In-Line Strainer. Remove screen and rinse thoroughly with water. Insert screen back into solenoid valve and screw cap on. Make sure the o-ring is placed properly.

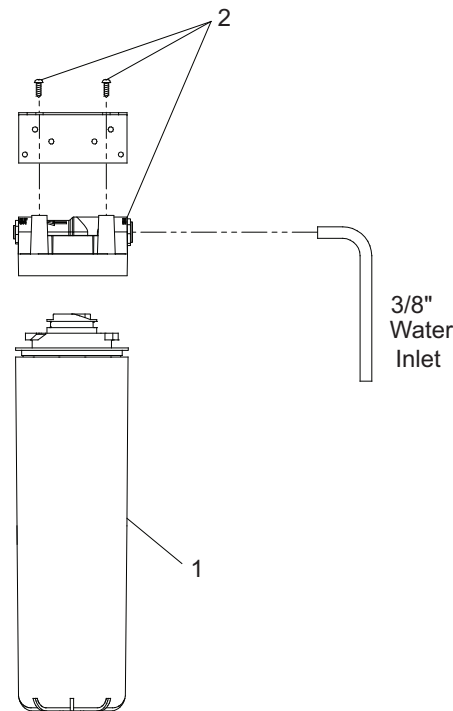

WATER FILTER EXPLODED VIEW

Replacement Parts: WaterSentry Filter Parts List

Item No.	Part No.	Description
1	51300C	Filter Assy-3000 Gal.
2	0000000746	Assy-Filter & Bracket includes Filter Head/Mounting Bracket/John Guest Fittings/Screws



Scan for troubleshooting information and to subscribe to automatic filter replacements at a discount.

Note: Danger! Electrical Shock Hazard. Disconnect Power Before Servicing Unit.

Replacement Parts: 230V Parts List

Item No.	Part No.	Description
1	28401C	Hanger Bracket
2	000001337	Basin - Stainless Steel
3	36216C	Wiring - Front/Side Push Bar
4	100002147	Compr - Service Pak (230V/50Hz)
5	56092C	Polytube - (Cut To Length)
6	56229C	Assy-Shroud-Upper (Front Side Push)
7	66703C	Drier
8	100001877	Kit - Drain Replacement EZ (BF)(Brckt, Tube, Ftg, Clamp)
9	55996C	In-Line Strainer
10	100004575	Kit-Solenoid Valve/Regulator Assy
11	56073C	Kit - Flexi Bubbler/O'-Ring/Nut
12	98734C	Kit - Pushbar (Front/Side) EZS TL
13	100001600	Kit - Pushbar (Front) EZS TL
14	98773C	Kit - Cold Control/Screws
15	98774C	Kit - Internal Wiring/Pwr Cord/Black and White Jumper Wires
16	000000245	Kit - Fan Motor Assy/Blade/Mtr/ Screws/Nut
17	98776C	Kit - Condenser/Drier
18	98777C	Kit - Compr Mlg Hdwe/Grommets/Clips/ Studs/Control
19	98778C	Kit - Heabv/Drier
20	98898C	Kit - Hardware (EZ)
21	98751C	Kit - Relay/Overload/Cover (220v/50Hz)
22	98724C	Kit - Evaporator Assembly
23	100000262	Tee - 1/4" x 1/4" x 3/8" (3 Pack)
24	100001602	Kit - 75583C Elbow 5/16" x 1/4" (3 Pack)
25	100004564	Kit - Regulator Assembly
26	100001812	Kit - Bottle Filler Drain (EZ)
27	36004C	Wire - Jumper (White)
28	97446C	VR Bubbler Assembly
29	36300C	Jumper Wire (Yellow)
30	27416C	Wrapper (Stainless)
31	27413C	Wrapper (Light Grey)
32	See Filter Table	Water Filter Kit (When Provided)
33	36066C	Internal Power Cord
34	36067C	Internal Power Cord Non-Refrigerated
35	28030C	Brkt - Power Inlet
36	35826C	Inlet Power

Replacement Parts: Bottle Filler Parts List

Item No.	Part No.	Description
NS	98631C	Kit - Electrical Package-230V
NS	98544C	Kit - IR Sensor
NS	1000004574	Kit - BF Solenoid Valve Replacement-230V
NS	98546C	Kit - Aerator Replacement
28	98547C	Kit - Top Cover Replacement
NS	98549C	Kit - Hardware & Waterway Parts
NS	98551C	Kit - Filter Mounting Cover
NS	98552C	Kit - Retro Filter Mounting
NS	100001813	Kit - Tower/Basin Gasket

NS= NOT SHOWN *Includes Relay & Overload. If under Warranty, replace with same Compressor used in original assembly. NOTE: All correspondence pertaining to any of the above water cooler or orders for repair parts MUST include Model number and Serial number of cooler, name and part number of replacement part.

