

# 3.5 Gallon Round UN Solids Container

## Features

- UN package for solid hazardous materials when used with 5LTBU lid
- Rated & certified for solid materials of medium hazard level up to 59.4 lbs.
- Reinforcing ribs maintain container shape
- Tapered design allows for container nesting
- Heat transfer decoration and 6 color offset print capability
- Accepts plastic or metal handle

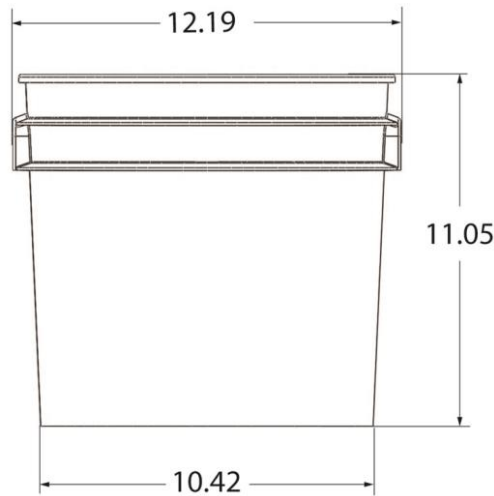

**PRODUCT CODE**.....3590U TU35G90STUNS (W) (B) (BU)

**COMPATIBLE LIDS**.....5LTBU LU5GUNGTS  
5LTB LA5GGT7S

## SPECIFICATIONS

Height.....11.05"  
Outer Diameter.....12.19"  
Thickness.....90 mil  
Print Area.....32.5" x 6"  
Resin.....HDPE

## VOLUME

Practical Fill.....4.00 gal. / 15.14 liters  
Overflow.....4.20 gal. / 15.90 liters

## PACKAGING

Pack Count.....144  
Pack Dimensions.....48.6" x 36.6" x 44.2"  
Cubic Feet.....44.8  
Packs per Pallet.....2

## ORDER QUANTITIES (53' Truckload)

3590U & 5LTBU or 5LTB .....7,920 bases & lids

The above information is general sales material only. LETICA MAKES NO WARRANTIES HEREIN, EXPRESS OR IMPLIED, INCLUDING THE WARRANTY OF MERCHANTABILITY OR FITNESS FOR A PARTICULAR USE OR PURPOSE. As Leticia continues to improve its products and processes, Leticia reserve the right to alter or modify any product and/or specification at any time without notice or obligation. Please contact your Leticia sales representative to ensure you have the most recent product information.

### DISCLAIMER

THIS INFORMATION IS PROVIDED AS A GENERAL GUIDE, INCLUDING DIMENSIONS. IT IS THE CUSTOMER'S RESPONSIBILITIES TO SELECT THE PROPER CONTAINER FOR PRODUCT AND APPLICATION COMPATIBILITY.

DISTRIBUTED BY:



REF NO.:

DWG30227

DESCRIPTION:

3.5 Gallon HDPE OH Pail