

SINCE 1839

BRINLY

SINCE 1839

BRINLY

KIT INSTRUCTIONS

STAKE SIDE KIT

FOR MODEL:

10P and 17P

- Assembly
- Installation
- Safety

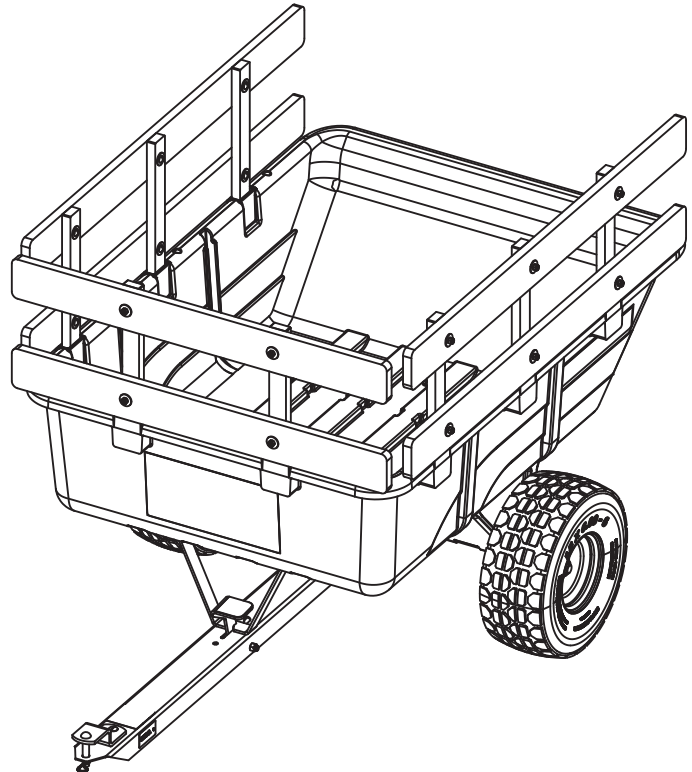

Visit us on the web!
www.brinly.com

Important: This manual contains information for the safety of persons and property. Read it carefully before assembly and operation of the equipment!

Part 1009488 Rev A

Fig 1 - Stake Side Assemblies

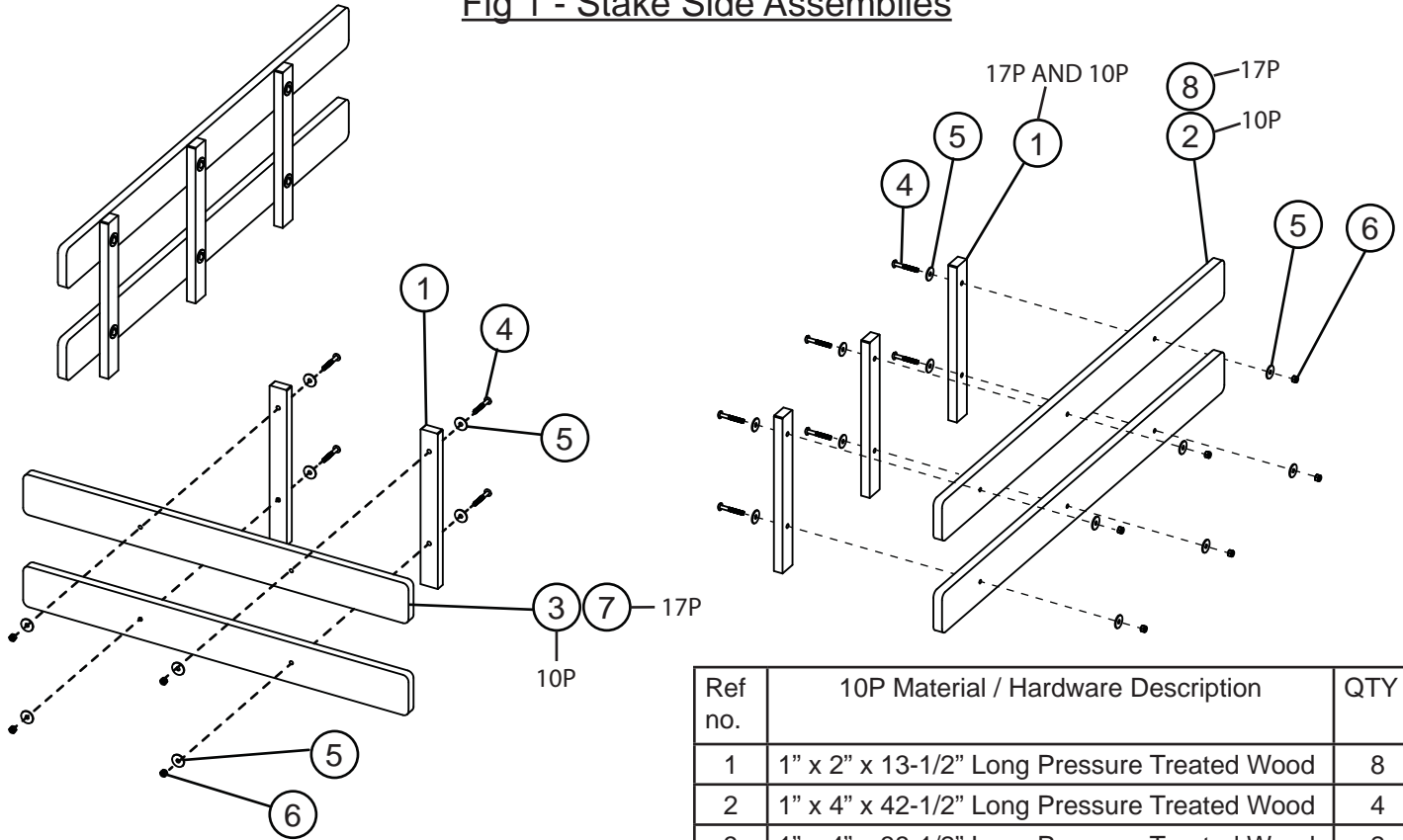

Ref no.	10P Material / Hardware Description	QTY
1	1" x 2" x 13-1/2" Long Pressure Treated Wood	8
2	1" x 4" x 42-1/2" Long Pressure Treated Wood	4
3	1" x 4" x 33-1/2" Long Pressure Treated Wood	2
4	1/4-20 x 2" Pan Head Bolt	16
5	1/4 Fender Washer	32
6	1/4-20 Nylon Locking Hex Nut	16

Ref no.	17P Material / Hardware Description	QTY
1	1" x 2" x 13-1/2" Long Pressure Treated Wood	10
8	1" x 4" x 55-3/4" Long Pressure Treated Wood	4
7	1" x 4" x 39" Long Pressure Treated Wood	2
4	1/4-20 x 2" Pan Head Bolt	20
5	1/4 Fender Washer	40
6	1/4-20 Nylon Locking Hex Nut	20

Material Notes:

1. It is recommended that all fasteners are plated grade 5
2. All material listed can be purchased at a standard hardware store

Install the completed Stake Side Rails
Into the cart side pockets as shown

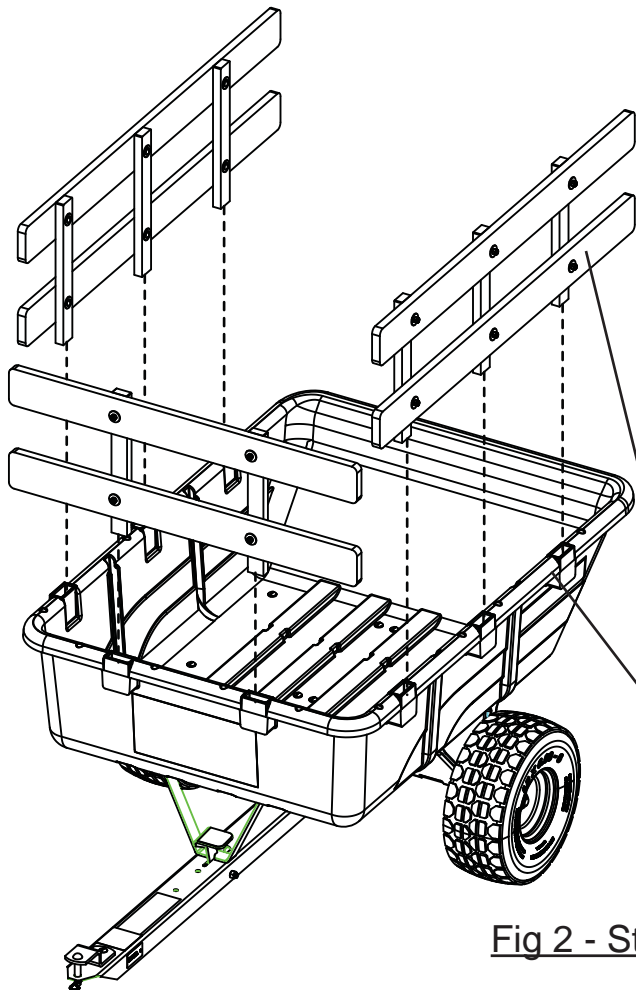
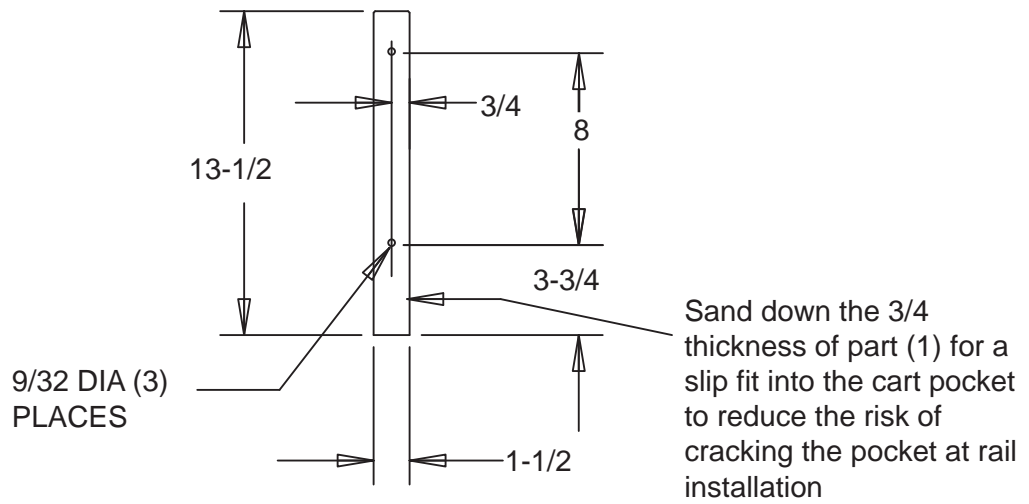
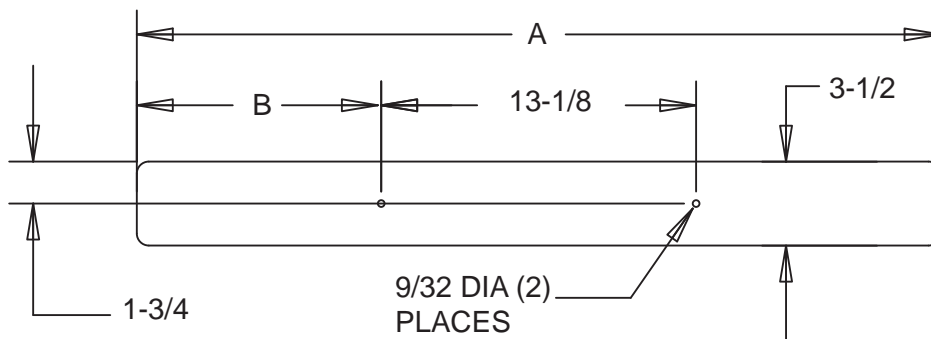

Fig 2 - Stake Sides Install

Fig 3 - Stake Sides Material Preparation



REF.NO. 1 (FOR 10P AND 17P)
1 X 2 PRESSURE TREATED WOOD



REF.NO. 3 (FOR 10P) A = 33-1/2 B = 10-3/16
REF.NO. 7 (FOR 17P) A = 39 B = 12-15/16
1 X 4 PRESSURE TREATED WOOD

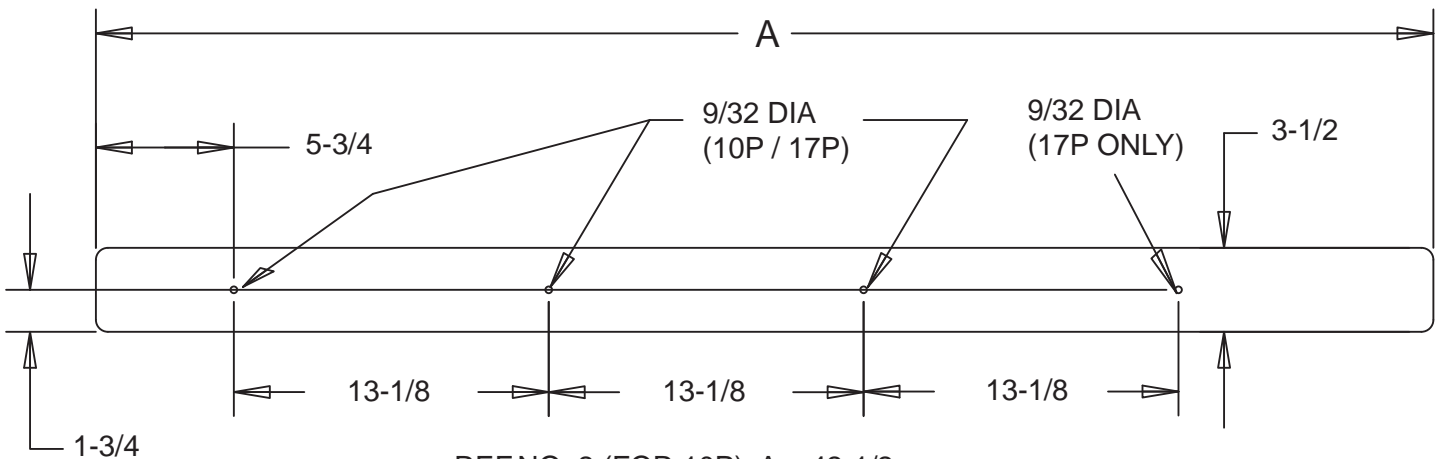

REF.NO. 2 (FOR 10P) A = 42-1/2
REF.NO. 8 (FOR 17P) A = 55-3/4
1 X 4 PRESSURE TREATED WOOD

Fig 4 - Permanently Secure Sides

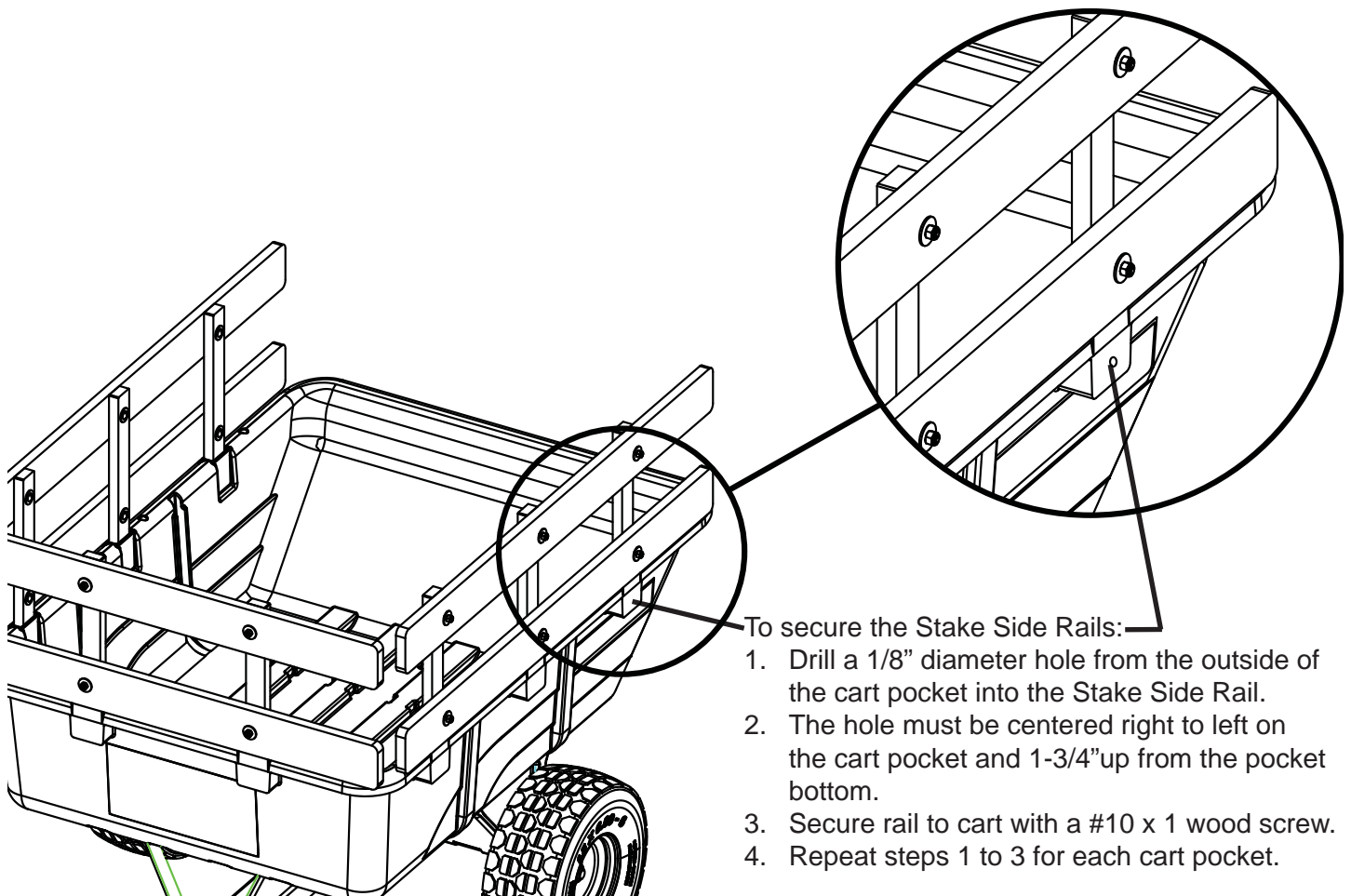

Safety: ⚠

- Read and follow the operating instructions for your machine and your Brinly Poly Cart.
- The stake side kit is for transporting light debris only, such as leaves, straw, and sticks.
- Do not load material higher than the top of the stake side rails.
- Do not use the stake side rails to increase the weight capacity of your cart (Refer to your cart manual for cart weight capacity)
- To minimize cart tip hazard, do not load heavy material like sand or firewood above the top of the cart bed.
- Do not let children or any untrained person operate the machine. Do not let anyone especially children ride on or in the cart during operation. Riders can be subject to injury from foreign objects and being thrown off the cart. Riders can also obstruct the operators view resulting in the machine being operated in an unsafe manner.
- Distribute the load evenly for safe travel and for unloading the cart
- Do not reach through the stake side rails with hands, arms, or head as these could become caught and cause injury.
- Do not secure loads to the stake side rails. Securely anchor all loads to the cart bed to prevent them from shifting and breaking the stake side rails.
- Do not use the stake side rails as a ladder, platform, or table.
- When using the stake side rails be sure to use all three sides together. Do not use only one side or just two sides.
- Inspect wood for rot and fasteners for rust before use and replace rotted, rusted, or worn parts as needed.