

Item # : BRSPDB

Assembly Instructions

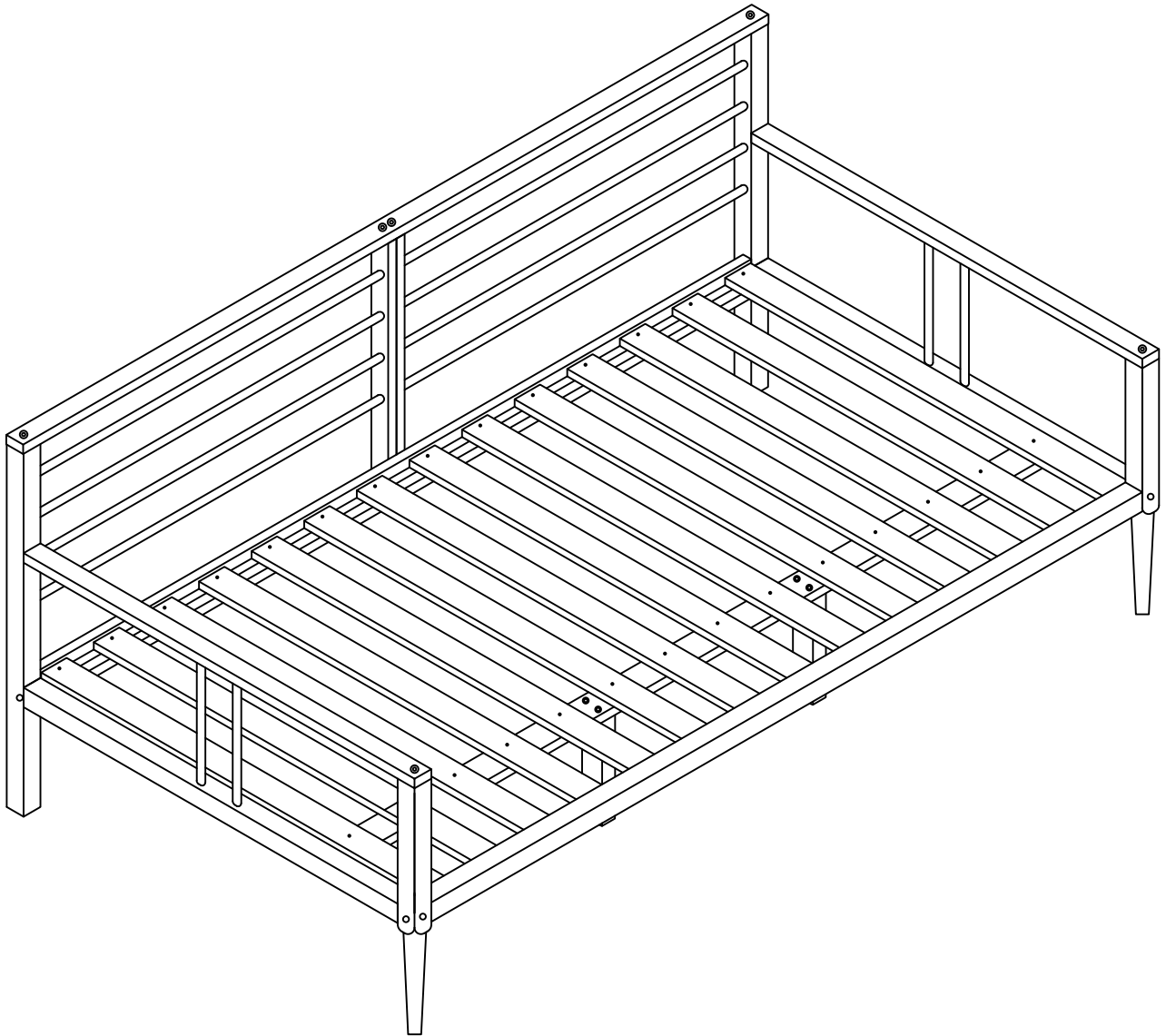

Please visit our website for the most current instructions, assembly tips, to report damage or request parts. www.walkeredison.com

Revised 10/2023 - V5

General Assembly Guidelines

- I. Ensure that all parts and hardware are available before beginning assembly.
- II. Follow each step carefully to ensure the proper assembly of this product.
- III. Two people are recommended for ease in the assembly of this product.
- IV. The three main types of hardware used to assemble this product are wood dowels, screws and bolts.
- V. A Phillips head screwdriver is required for the assembly of this Product.

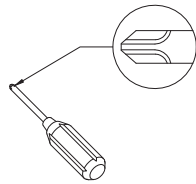

- VI. Power tools should not be used to assemble this product.

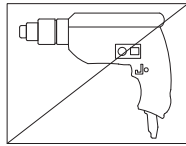



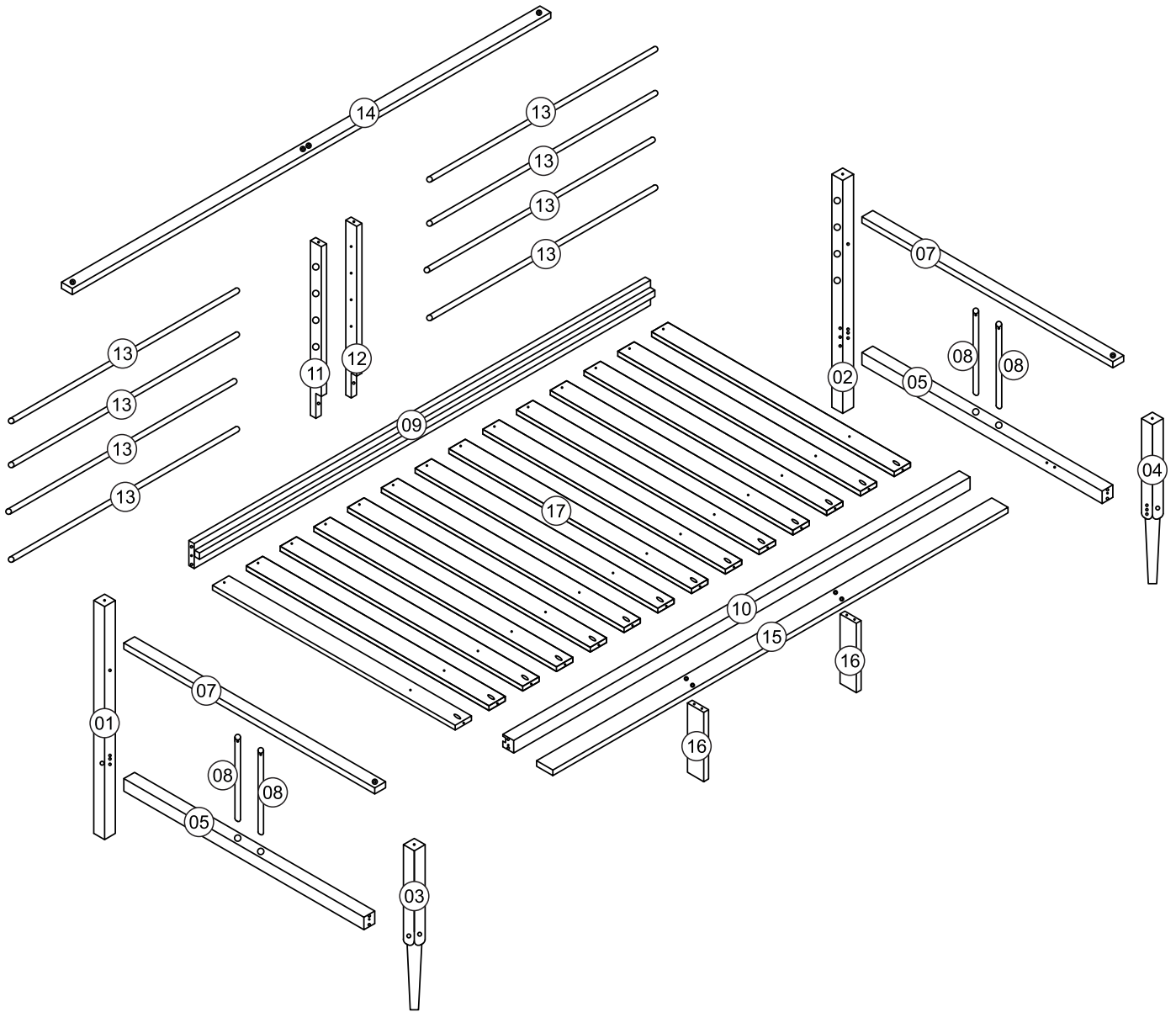

Parts List

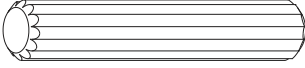
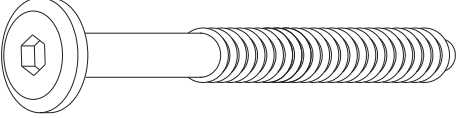

Part#	Description	Qty	Part#	Description	Qty
1	Back left leg	01 pcs	9	Back rail	01 pcs
2	Back right leg	01 pcs	10	Front Rail	01 pcs
3	Front left leg	01 pcs	11	Left rear rail	01pcs
4	Front right leg	01 pcs	12	Right rear rail	01 pcs
5	Bottom Rail	02 pcs	13	Spindle Back	08 pcs
7	Top side rail	02 pcs	14	Top rail	01 pcs
8	Side Spindle	04 pcs	15	Center supportt	01 pcs
			16	Center Foot	02 pcs
			17	Slats	14 pcs

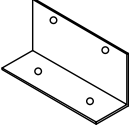
Hardware List

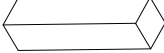
A		ø8"*40mm	Wood dowel	16 pc
B		ø7,0"*60mm	Bolt	12 pcs
C		ø7,0"*90mm	Bolt	10 pcs
D		ø3.5*20mm	Screw	08 pcs
E			Metal Plate Connector	02 pcs
F		ø3.5*35mm	Screw	58 pcs
G			Hex key	01 pc
I		73 mm	Spacer	02 pcs

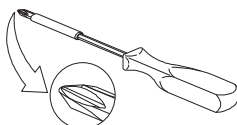

Philips head screwdriver required
for assembly (not included)

*The hardware quantities listed above are required for proper assembly.
Some extra hardware may also have been included.*

Step 1

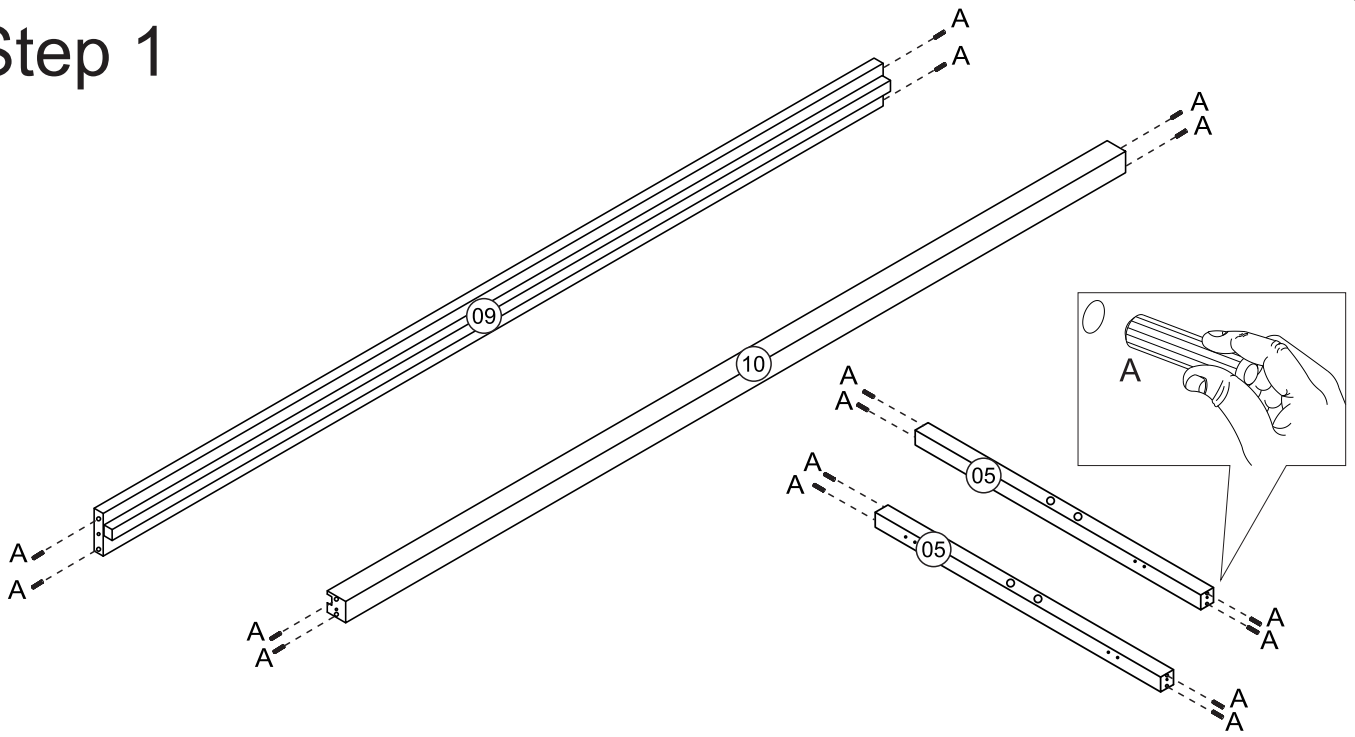

Insert wooden dowels (A)
into parts 5,9 And 10

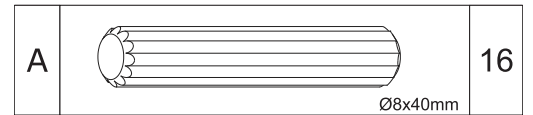

Step 2

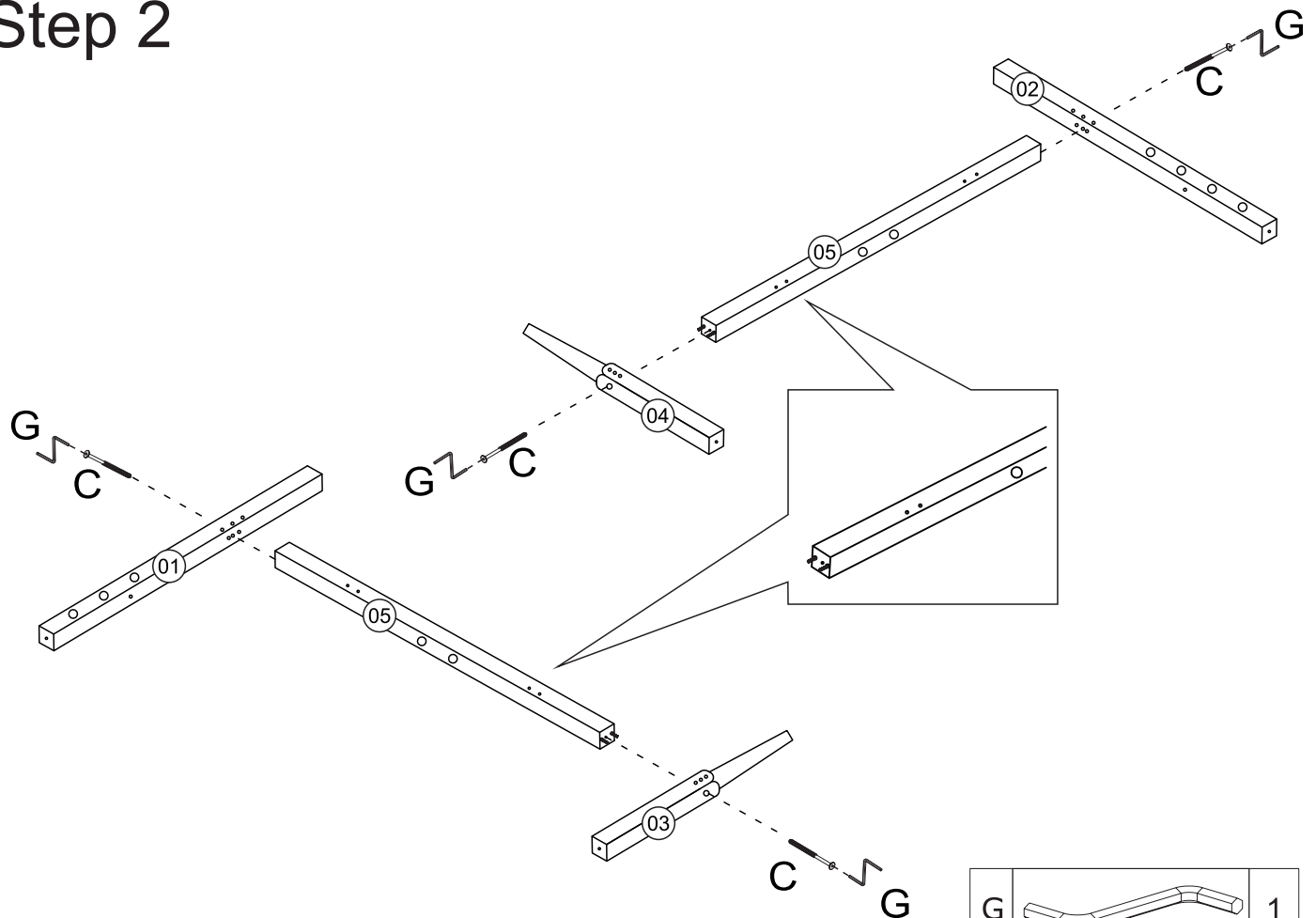

Connect parts 01,02,03,04 to
part 05 with the bolt (C)
using hex key (G)

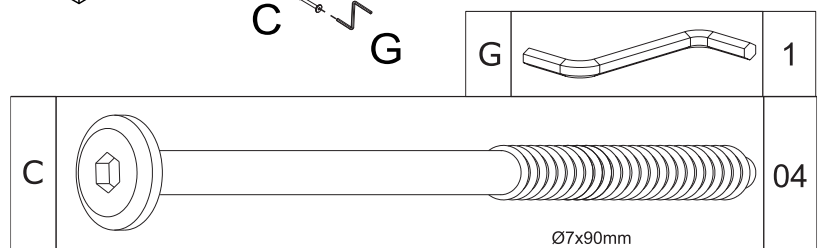

Step 3

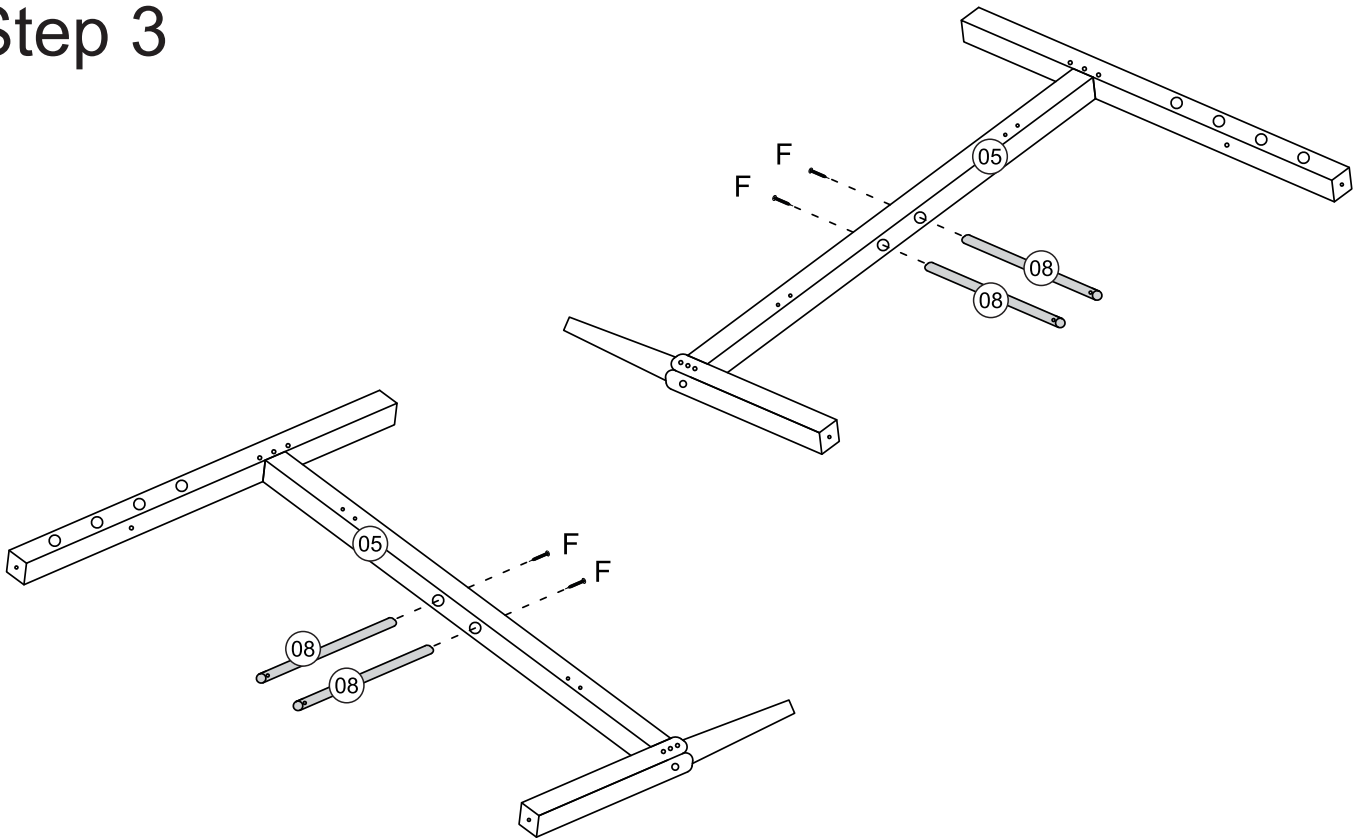

Connect parts 08 to part 05 with the screw (F) using Phillips head screwdriver

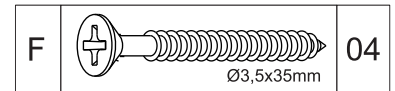

Step 4

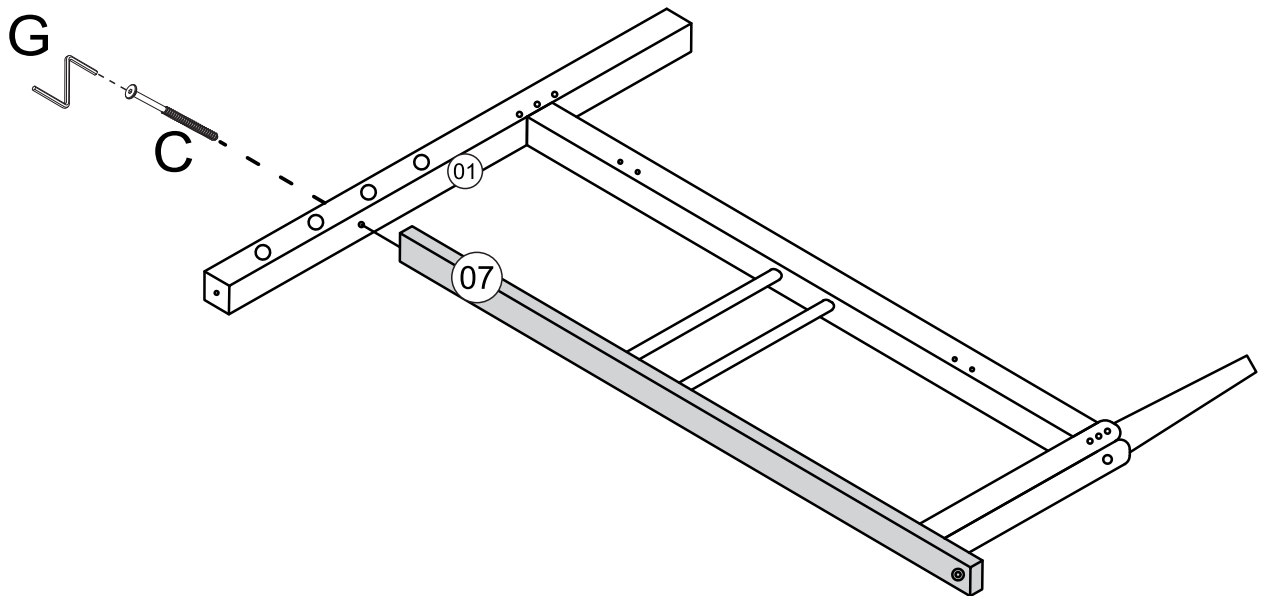

Connects part 01 to part 07 with the bolt (C) using hex key (G)

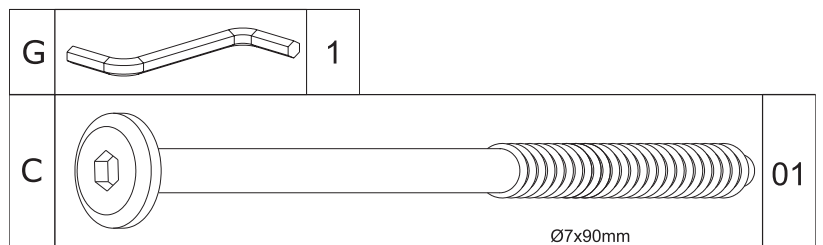

Step 5

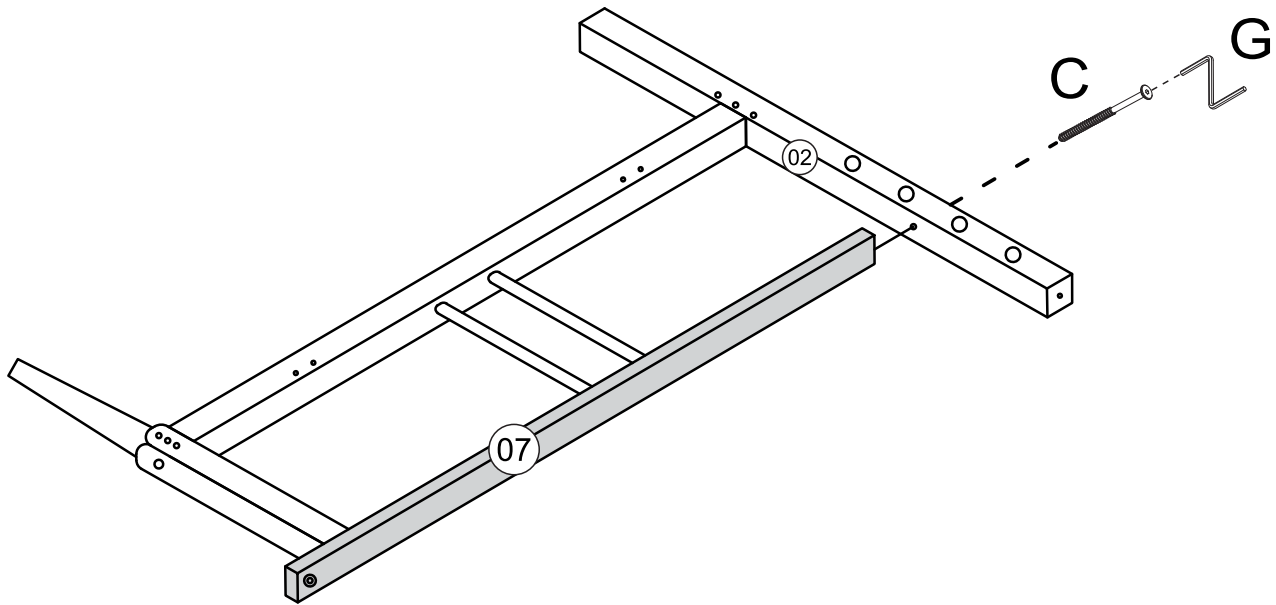

Connect part 02 to part 07 with the bolt (C) using hex key (G)

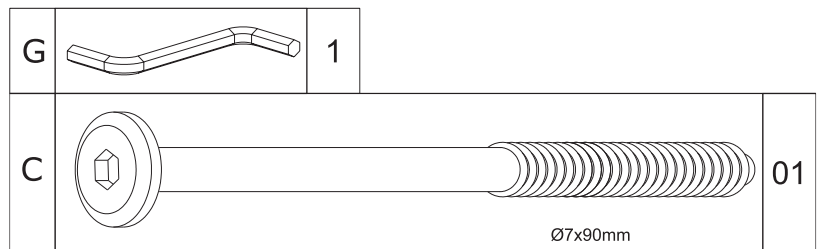

Step 6

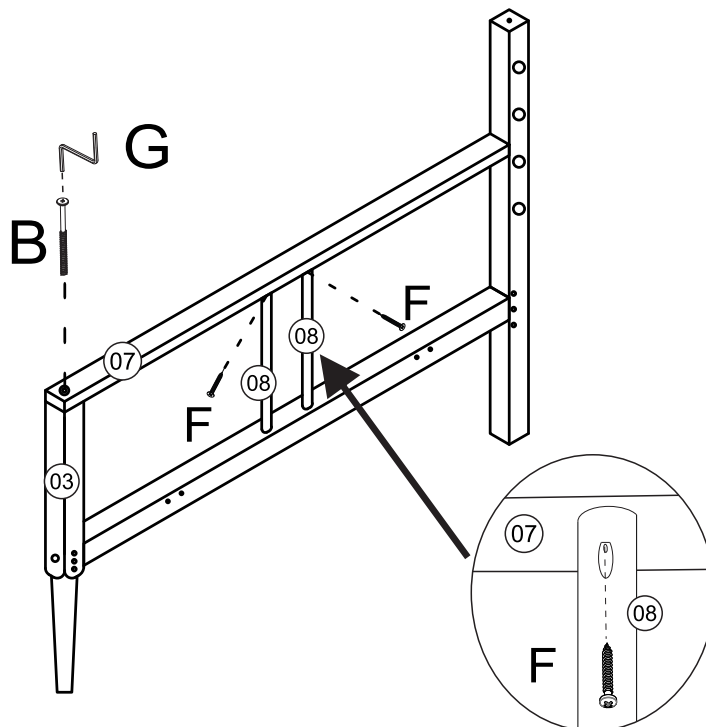

Connect part 08 to part 07 with screw (F) and phillips head screwdriver.
Connect part 07 to part 03 with bolt (B) with hex key (G).

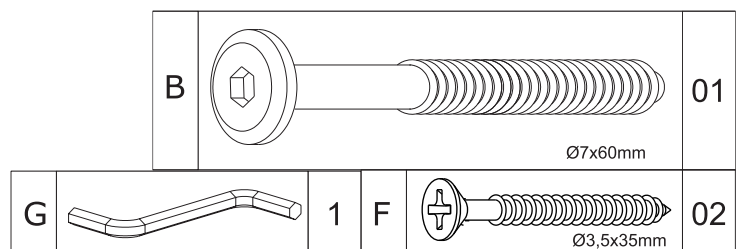

Step 7

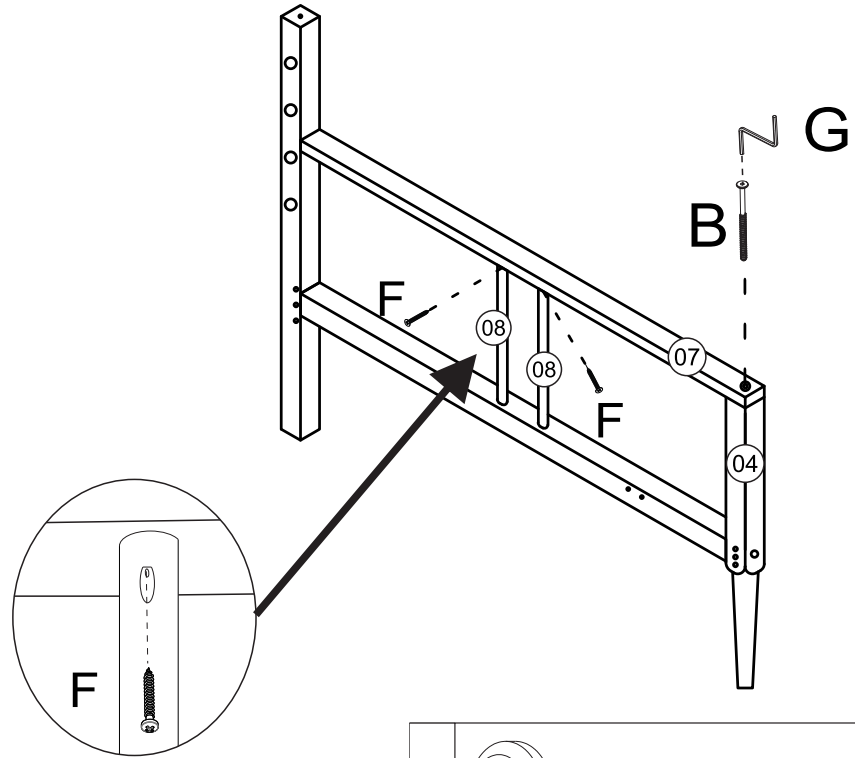

Connect part 08 to part 07 with screw (F) and phillips head screwdriver.

Connect part 07 to part 04 with bolt (B) with hex key(G).

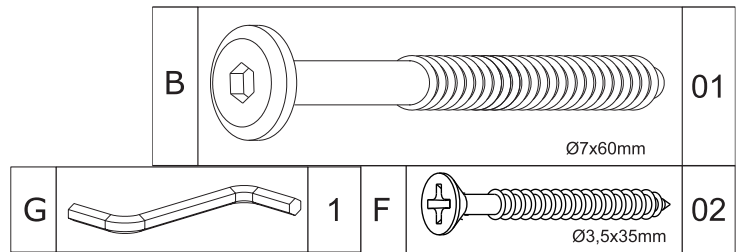

Step 8

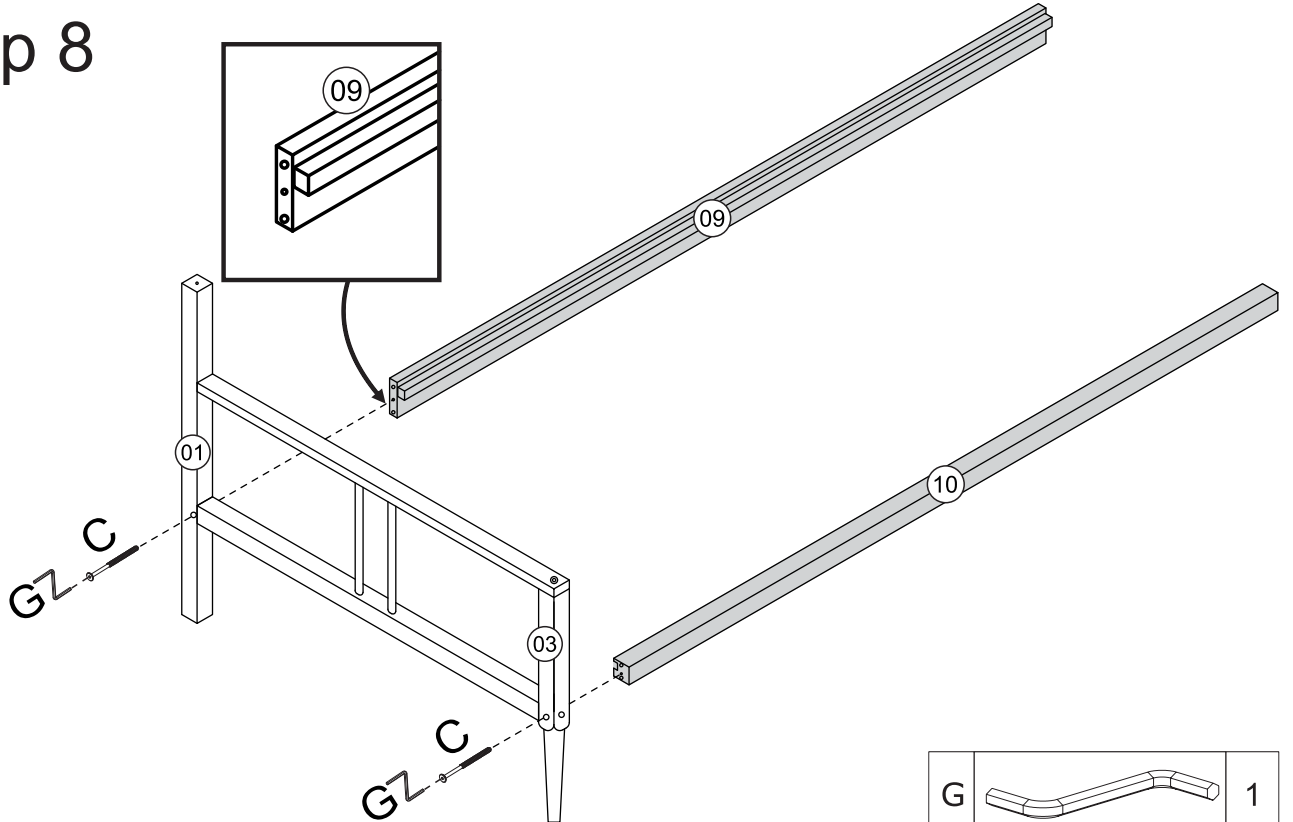

Connect part 09,10 to parts 01 and 03 with bolt (C) with hex key(G).

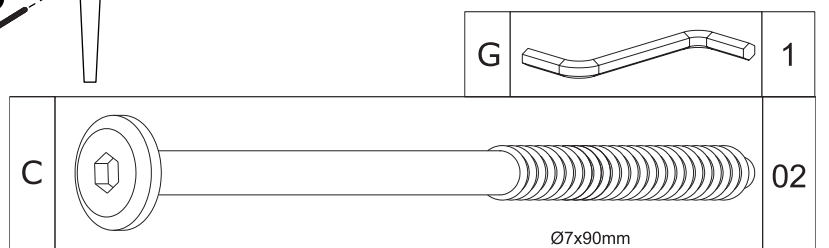

Step 9

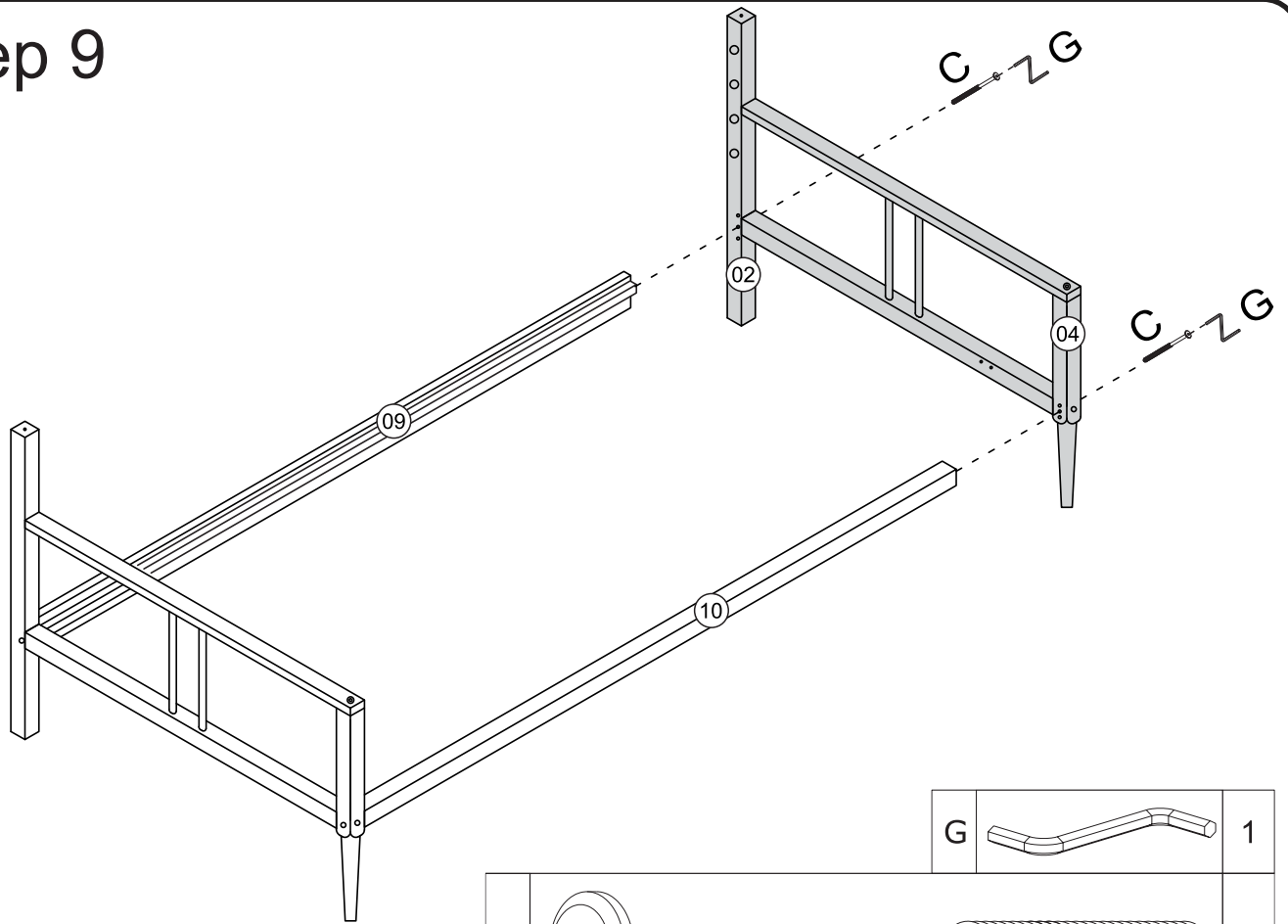

Connect part 09, 10 to part 02 and 04, with bolt (B) with hex key (G).

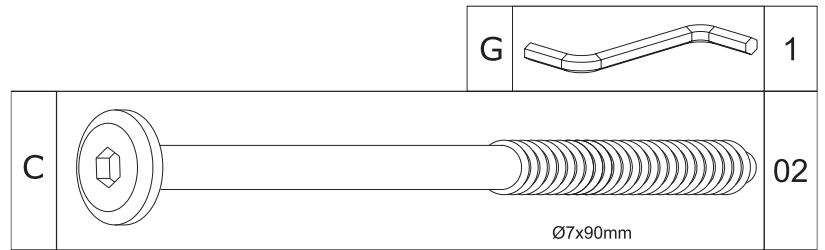

Step 10

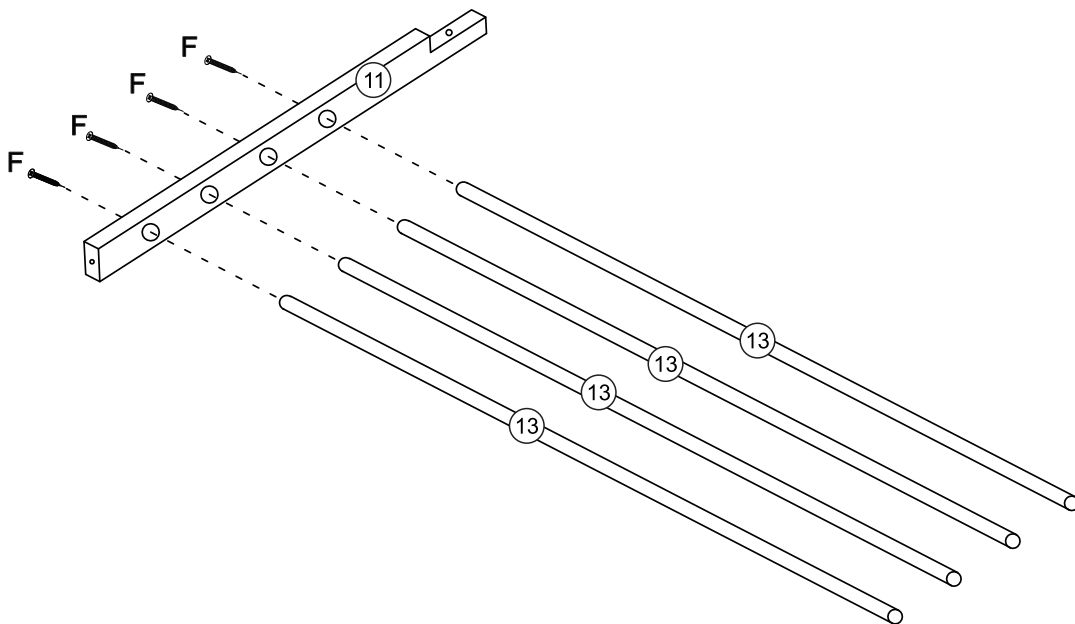

Secure parts 13 to part 11 with the screw (F) using Philips head screwdriver

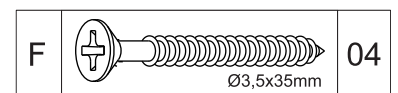

Step 11

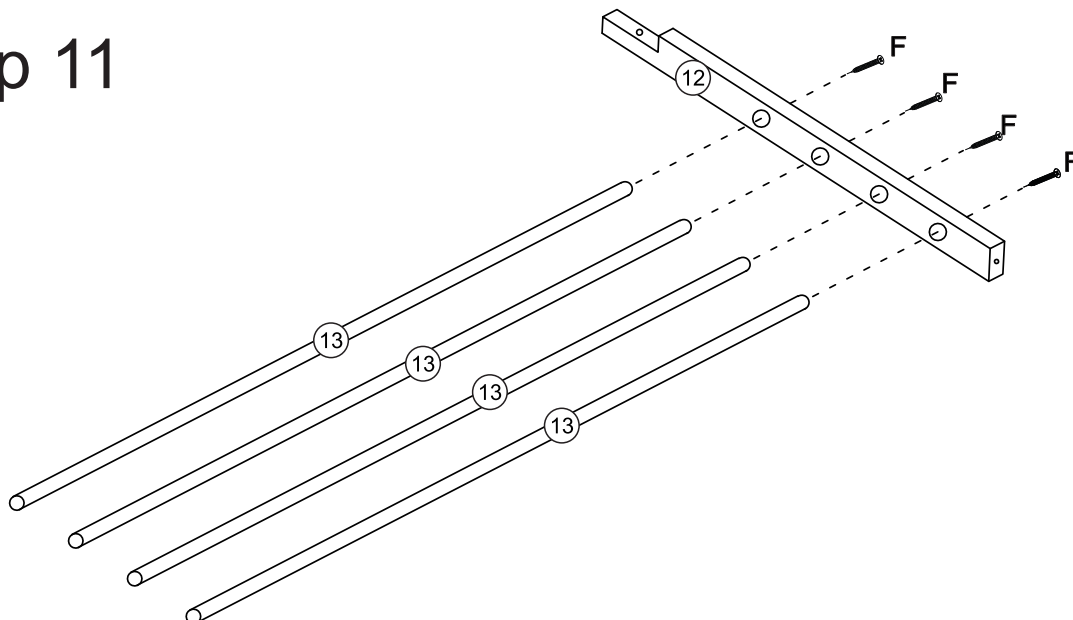

Secure parts 13 to part 12 with the screw (F) using Philips head screwdriver

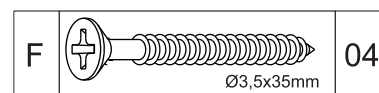

Step 12

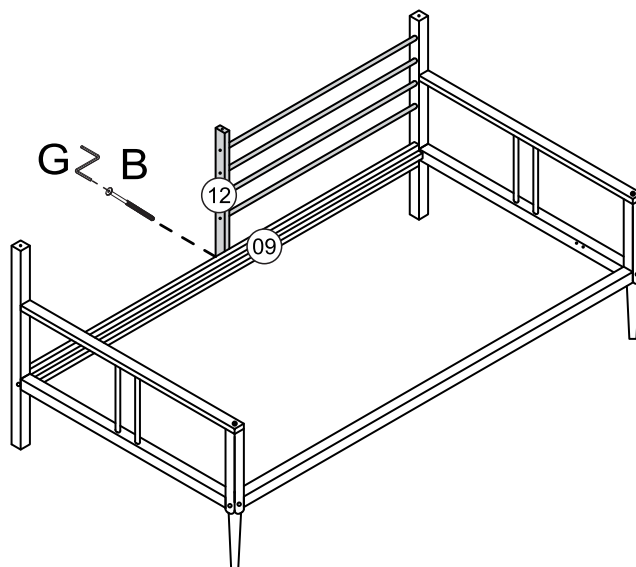
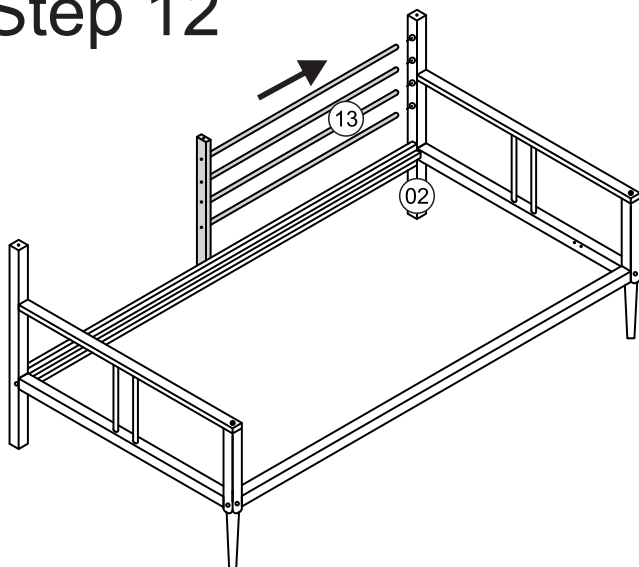

Connect parts 13 to part 02
Secure part 12 to part 09 with the bolt (B)
using hex key (G)

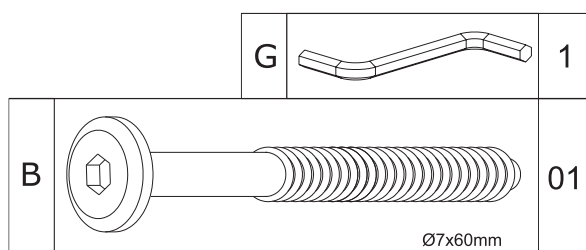

Step 13

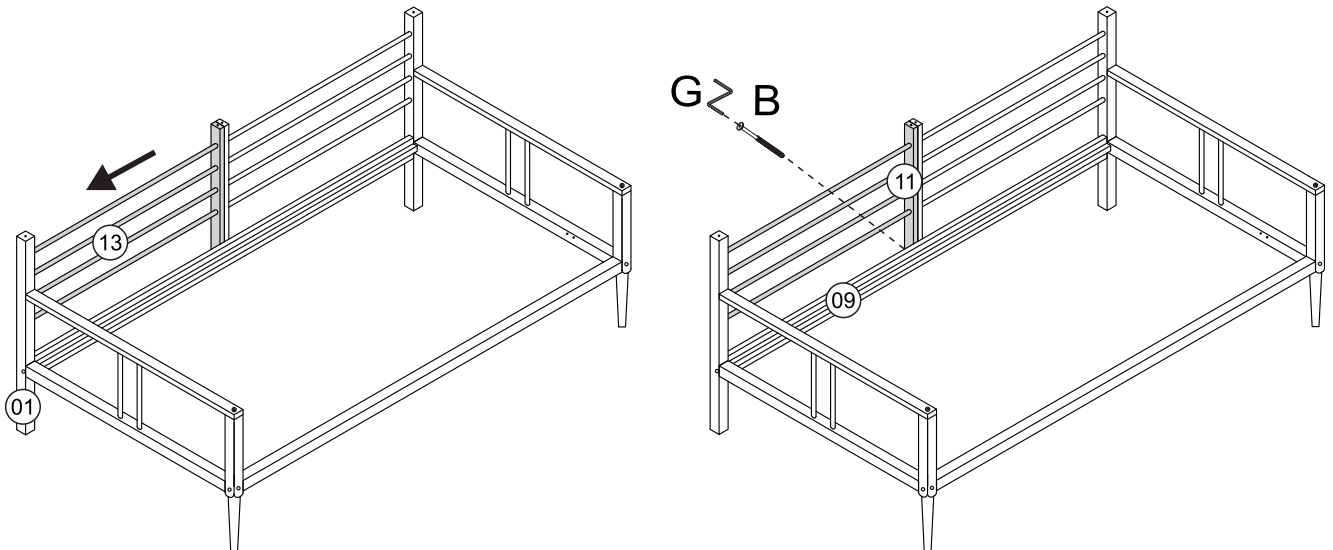

Connect parts 13 to part 01
Secure part 11 to part 09 with the bolt (B)
using hex key (G)

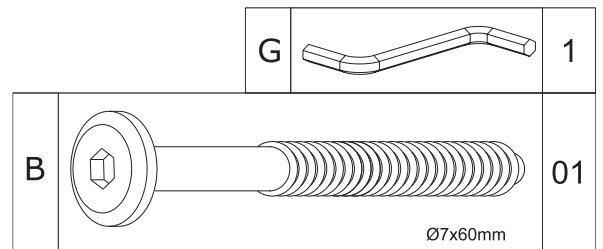

Step 14

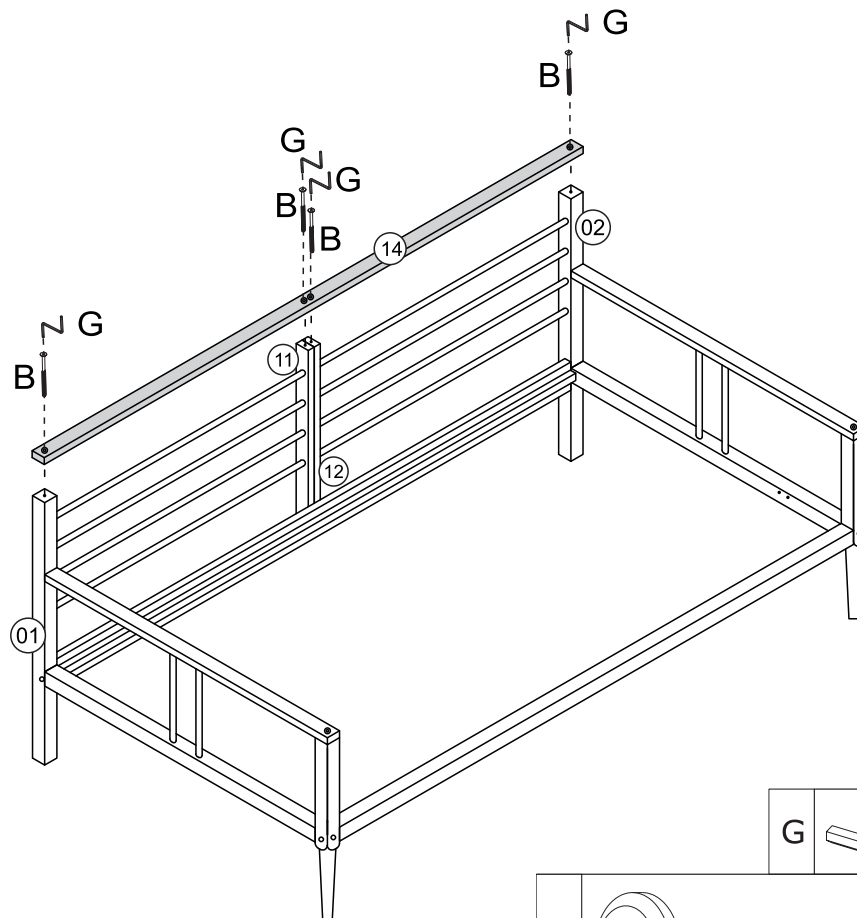

Connect part 14 to part 01,02,11 and 12, with
bolt (B) with hex key(G).

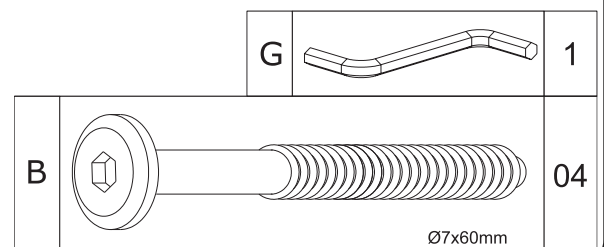

Step 15

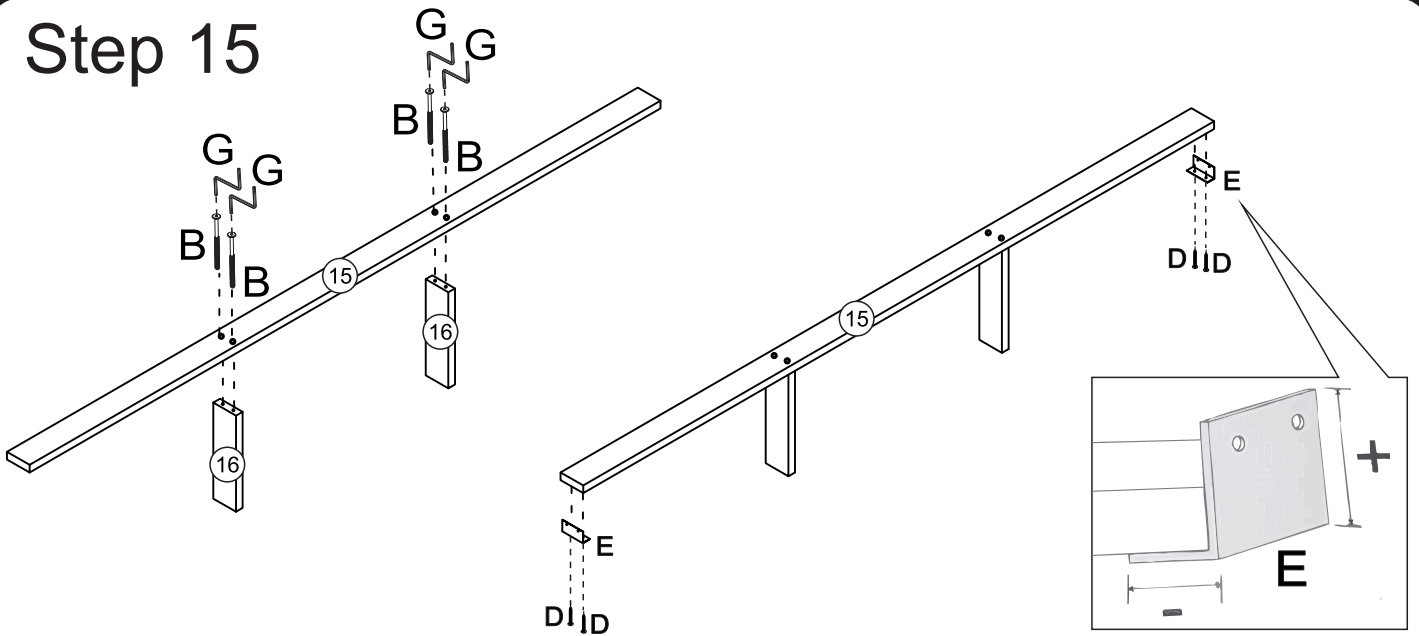

Connect part 15 to parts 16 with the bolt (B) using hex key (G), connect hardware (E) to part 15 with the screw (D) using Phillips head screwdriver

G		1
D		04
E		02
B		04

Step 16

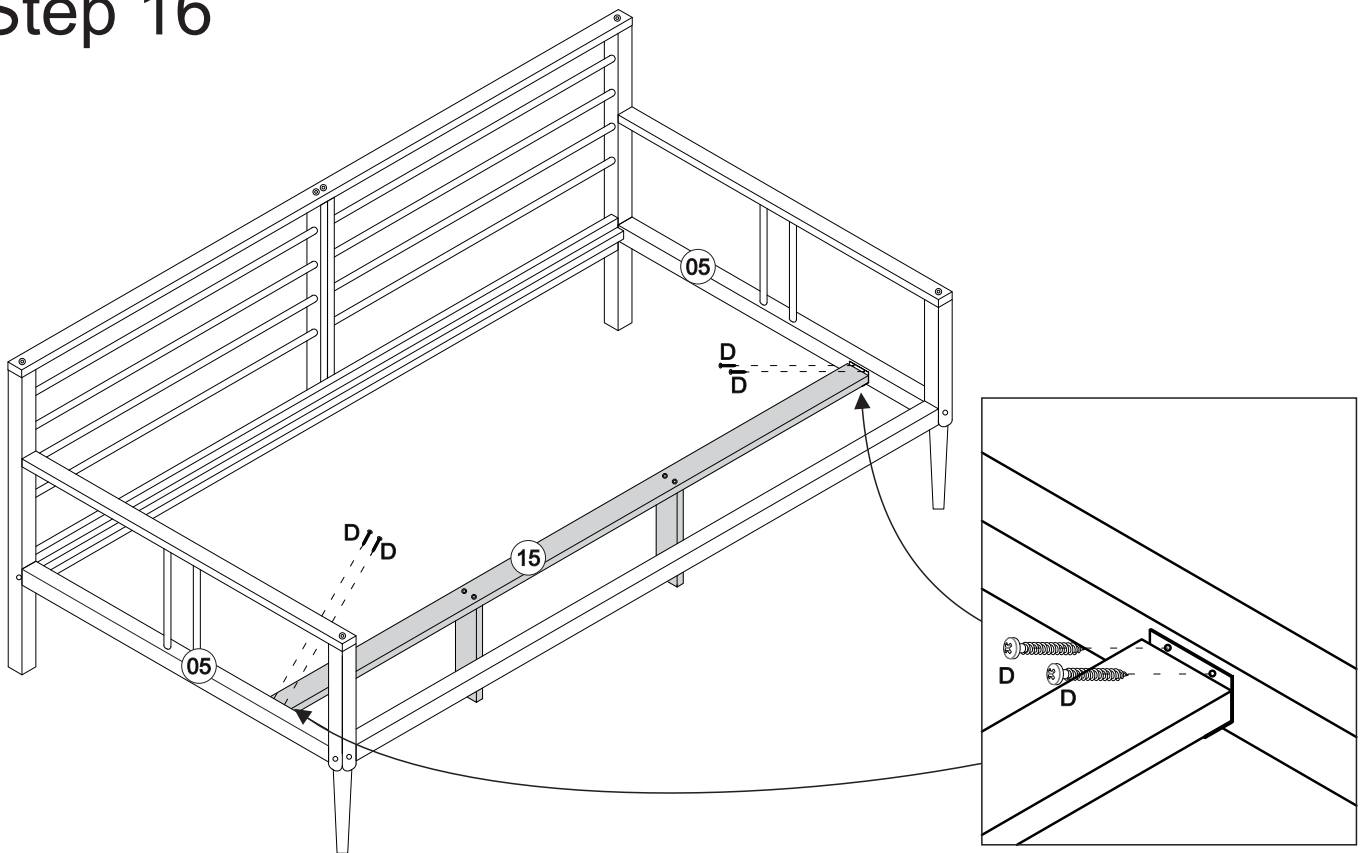

Connect part 15 to part 05 in the pre-drilled holes with the screw (D) using phillips head screwdriver

D		04
---	--	----

Step 17

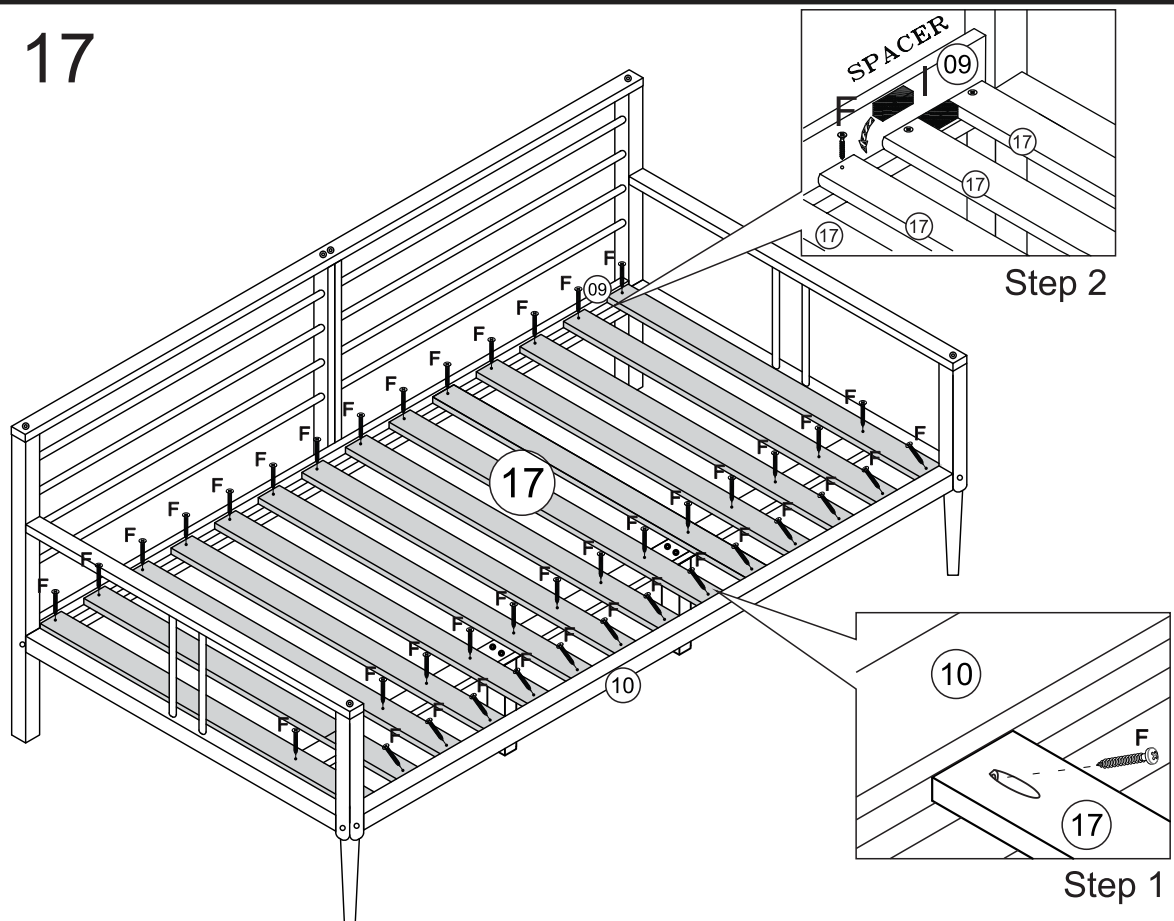

Using the spacer provided (I), place the bed slats (step 2) evenly along the parts 09,10. Connect parts 17 to parts 09,10 and 15 with the screw (F) using Philips head screwdriver

F		42
I		02

Step 18

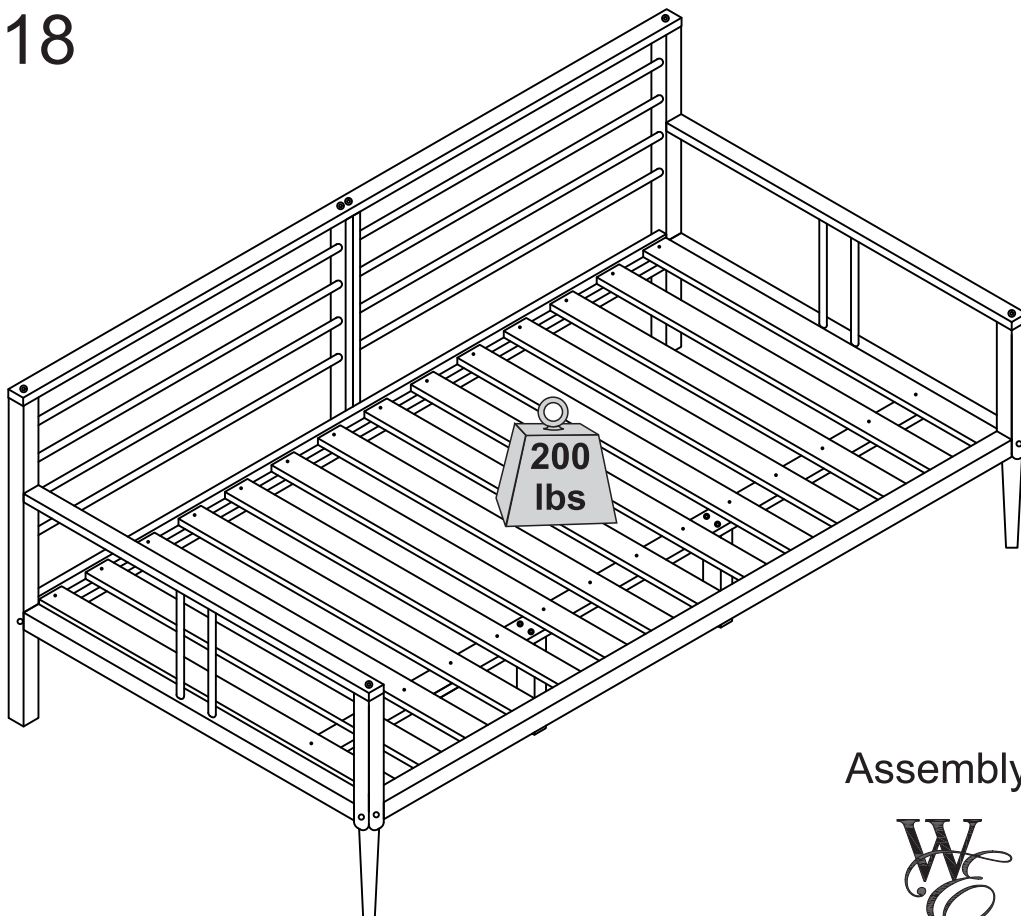

Assembly Complete!

Walker Edison®