



MANUFACTURED BY:
Backyard Discovery
3305 Airport Drive, Pittsburg, KS 66762
800-856-4445

Basepoint Business Centre: Rivermead Drive, Westlea, Swindon SN5 7EX Phone: 0800-118-2476
J.P. Coenstraat 7, The Bridge, The Hague, 2595 WP, Netherlands Phone: 0800-567-8990

ADVENTURER

Swing Set

Model # 2400382

The assembly manual must be retained
since it contains important information



WARNING

Adult Assembly Required.

Not suitable for children under 36 months due to small parts.

FOR DOMESTIC USE ONLY. INTENDED FOR OUTDOOR USE.

CAN ICES-003 (B)/NMB-003(B)



Please visit www.backyarddiscovery.com

For the most up to date assembly manual, to register your set, or to order replacement parts

Para obtener instrucciones en español, visite www.backyarddiscovery.com



**EASY STEP-BY-STEP
3D INTERACTIVE INSTRUCTIONS**
DOWNLOAD THE FREE APP



Owner's Manual - Basic Setup Dimensions & Assembly Notes

Place the set on level ground, not less than 6'-7" [2007 mm] from any structure or obstruction such as a fence, garage, house, overhanging branches, laundry lines, or electrical wires.

- While assembling unit, take time before and after each phase to make sure fort is level. If fort is not level, assembly will be difficult and improper assembly may result. Extra care must be taken to insure the fort is square.
- The safe play area refers to a zone extending 6'-7" (2007 mm) beyond the play product on all sides, including the space above the play product.

SAFE PLAY AREA DIAGRAM

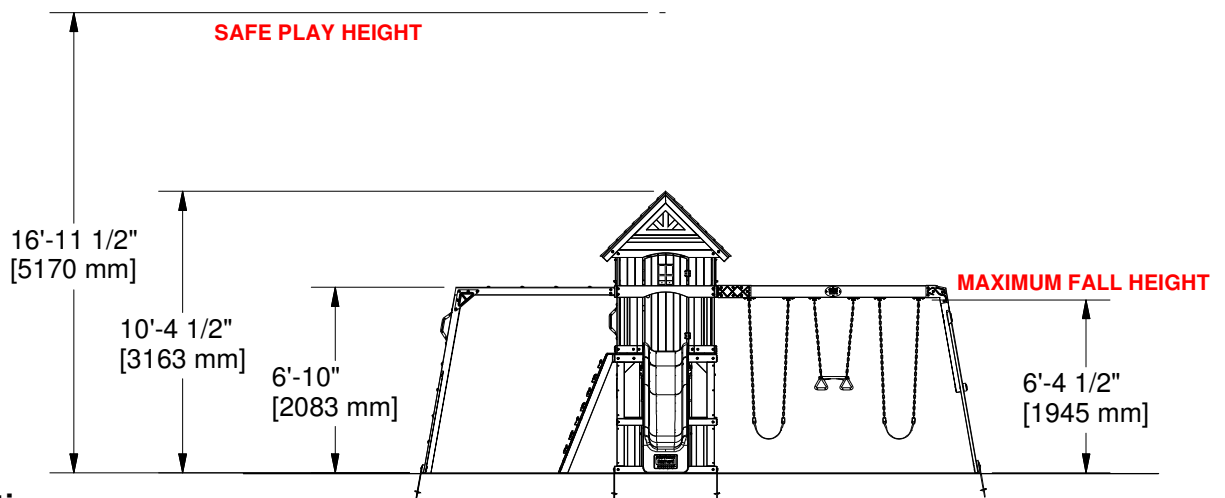
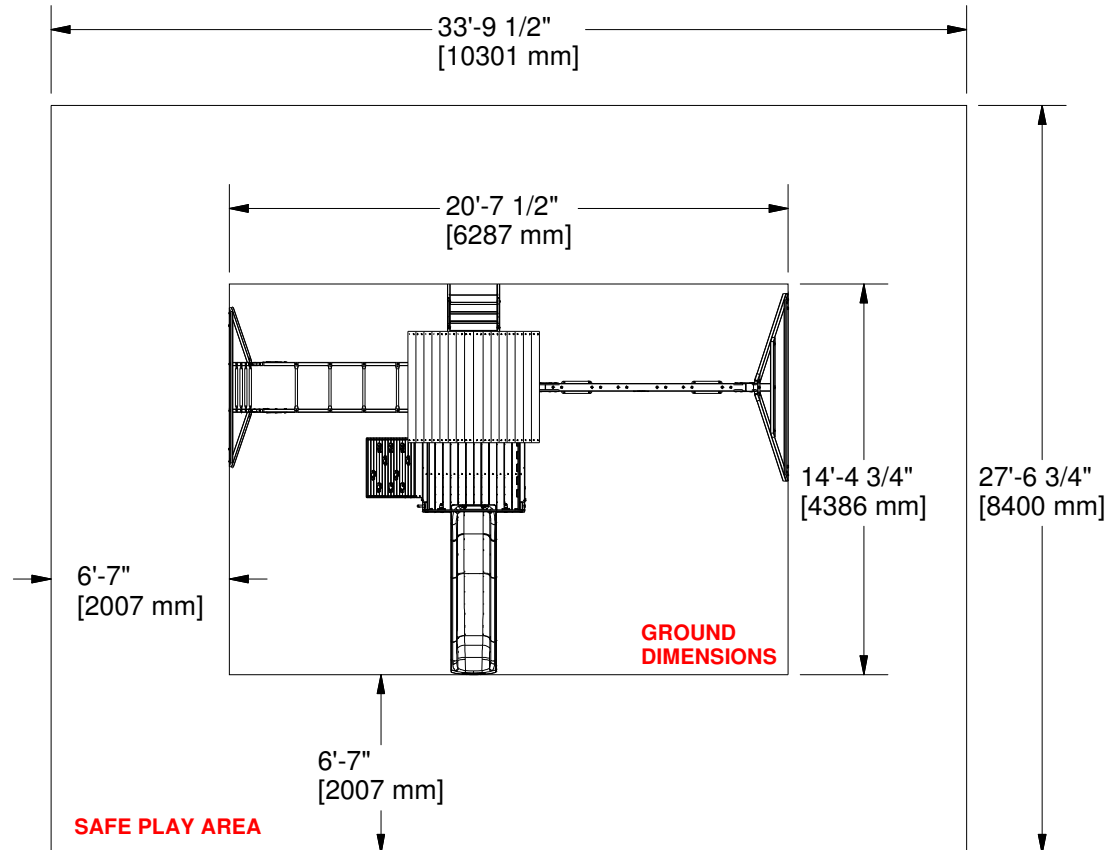

General Information:

Your set has been designed and engineered for children only and for residential use only.
A maximum of 150 lbs. per child is recommended for play activities designed for individual use.
A maximum of 120 lbs. per child is recommended for play activities designed for multiple child use.
A maximum of 9 children is recommended for this swing set.

OWNER'S MANUAL - PARTS IDENTIFICATION

Wood Components (Not to Scale)



A01 SWING BEAM - W4L22161
(x1) 3 3/8"x5 1/4"x89 1/2" (86x134x2274)



A02 SB 9" BLOCK - W4L22162
(x1) 3 3/8"x5 1/4"x9" (86x134x228)



E11 ANGLE BRACE - W4L22140
(x6) 1 1/8"x3 3/8"x14 5/8" (30x86x373)



E13 MONKEY BAR UPRIGHT - W4L22163
(x2) 1 3/8"x3 3/8"x80 3/8" (36x86x2043)

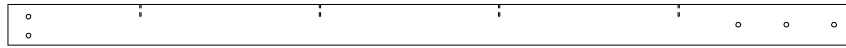

E74 MONKEY BAR RAIL - W4L22166
(x2) 1 3/8"x3 3/8"x70 7/8" (36x86x1800)



E79 END SUPPORT - W4L22159
(x1) 1 1/2"x3 1/2"x44" (36x86x1120)



E80 ANGLE BRACE - W4L22158
(x2) 1 3/8"x3 3/8"x83" (36x86x2108)



G50 GROUND BOARD - W4L22157
(x1) 1"x5 1/4"x82 13/16" (24x134x2104)



H01 FLOOR SUPPORT - W4L22142
(x1) 1"x3 3/8"x45 1/8" (24x86x1147)

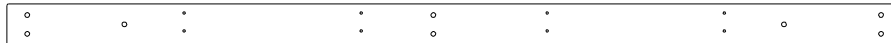

H03 FLOOR SUPPORT - W4L22139
(x1) 1"x3 3/8"x74 5/8" (24x86x1894)

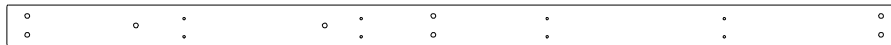

H04 FLOOR SUPPORT - W4L22148
(x1) 1"x3 3/8"x74 5/8" (24x86x1894)



H06 FLOOR SUPPORT - W4L22143
(x1) 1"x3 3/8"x45 1/8" (24x86x1147)

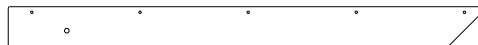

H12 ROOF TRUSS - W4L22129
(x4) 1"x3 3/8"x40" (24x86x1016)

OWNER'S MANUAL - PARTS IDENTIFICATION

Wood Components (Not to Scale)

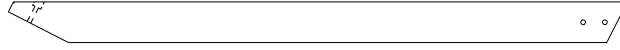

H81 MONKEY BAR BRACE - W4L22164
(x2) 1"x3 3/8"x51 5/8" (24x86x1311)



H82 MONKEY BAR GROUND BOARD - W4L22165
(x1) 1"x3 3/8"x70 3/8" (24x86x1786)



HB01 GROUND BOARD - W4L22130
(x1) 1"x3"x45 1/8" (24x76x1147)



HB03 GROUND BOARD - W4L22132
(x1) 1"x3"x74 5/8" (24x76x1894)

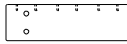

HB06 CLEAT - W4L22171
(x1) 1"x3"x10 1/4" (24x76x259)

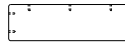

HB07 CLEAT - W4L22170
(x2) 1"x3"x10 1/4" (24x76x259)



HB08 CLEAT - W4L22172
(x1) 1"x3"x3 3/8" (24x76x86)



M01 UPRIGHT - W4L22141
(x2) 5/8"x3 3/8"x46" (16x86x1168)



M02 UPRIGHT - W4L22167
(x2) 5/8"x3 3/8"x24 7/8" (16x86x633)



M03 UPRIGHT - W4L22168
(x2) 5/8"x3 3/8"x18" (16x86x457)

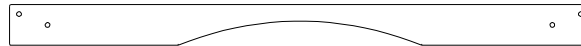

NG07 WALL RAIL - W4L22151
(x1) 3/4"x3 3/8"x48 3/8" (20x86x1230)

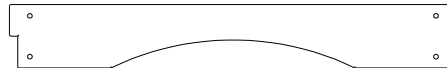

NJ01 WALL RAIL - W4L22150
(x1) 3/4"x5 1/4"x37 1/4" (20x134x946)



OB05 FLOOR JOIST - W4L22149
(x4) 1 1/8"x3"x43 1/4" (30x76x1099)



OG01 UPRIGHT - W4L22133
(x1) 1 1/8"x3 3/8"x82 7/8" (30x86x2104)

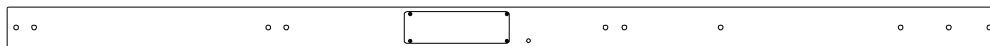

OG02 UPRIGHT - W2A04297
(x1) 1 3/8"x3 3/8"x89 1/2" (30x86x2104)

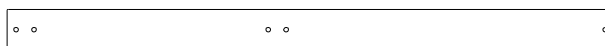

OG03 UPRIGHT - W4L22134
(x1) 1 1/8"x3 3/8"x50 5/8" (30x86x1287)

OWNER'S MANUAL - PARTS IDENTIFICATION

Wood Components (Not to Scale)



OG04 UPRIGHT - W4L22135
 (x1) 1 1/8"x3 3/8"x50 5/8" (30x86x1287)



OG05 UPRIGHT - W4L22144
 (x1) 1 1/8"x3 3/8"x47 7/8" (30x86x1217)



OG06 LOWER UPRIGHT - W4L22136
 (x1) 1 1/8"x3 3/8"x50 5/8" (30x86x1287)



OG07 UPRIGHT - W4L22137
 (x1) 1 1/8"x3 3/8"x50 5/8" (30x86x1287)



OG08 UPRIGHT - W4L22145
 (x1) 1 1/8"x3 3/8"x47 7/8" (30x86x1217)



OG09 UPRIGHT - W4L22146
 (x1) 1 1/8"x3 3/8"x47 7/8" (30x86x1217)



OG10 UPRIGHT - W4L22147
 (x1) 1 1/8"x3 3/8"x47 7/8" (30x86x1217)



SP71 SWING BEAM SUPPORT - W4L22160
 (x1) 3 3/8"x3 3/8"x46 1/4" (86x86x1176)

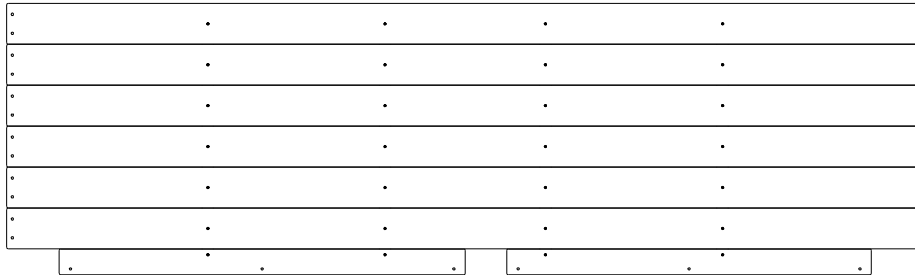

FP01 FLOOR PANEL - W2A04996
 (x1) 1 9/16"x22 11/16"x76 7/16" (40x573x1942)

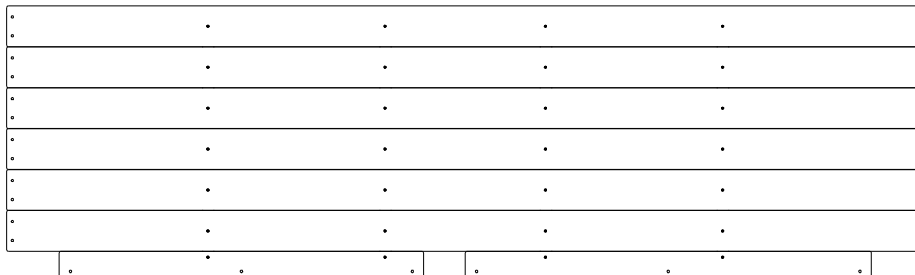

FP02 FLOOR PANEL - W2A04997
 (x1) 1 9/16"x22 11/16"x76 7/16" (40x573x1942)

OWNER'S MANUAL - PARTS IDENTIFICATION

Wood Components (Not to Scale)

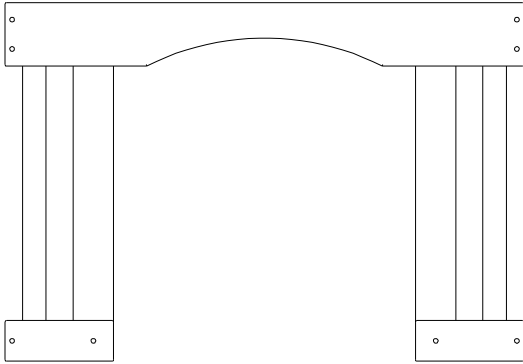

WP01 WALL PANEL - W2A04299
(x1) 1 7/16"x29 13/16"x43 1/2" (36x758x1099)

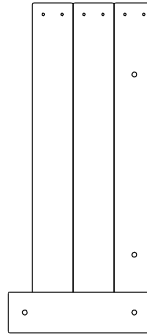

WP08 WALL PANEL - W2A05001
(x1) 2 1/16"x12 3/16"x27 7/16" (52x310x697)

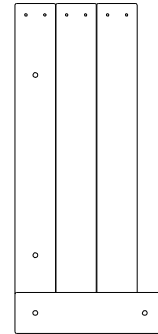

WP09 WALL PANEL - W2A05002
(x1) 2 1/16"x12 3/16"x27 7/16" (52x310x697)

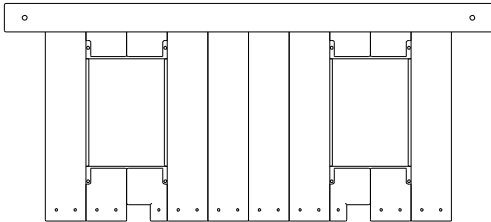

WP02 WALL PANEL - W2A04998
(x1) 2 1/16"x18 1/8"x40 11/16" (52x460x1034)

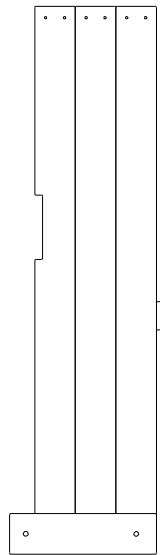

WP10 WALL PANEL - W2A05003
(x1) 2 1/16"x13 5/16"x45 5/8" (52x338x1158)



WP11 WALL PANEL - W2A05004
(x1) 2 1/16"x10 3/16"x45 9/16" (52x258x1158)

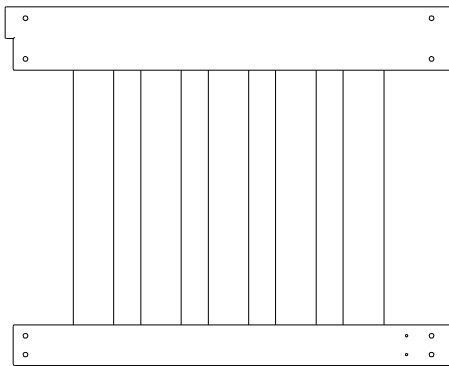

WP03 WALL PANEL - W2A04298
(x1) 1 7/16"x29 13/16"x37 1/4" (36x758x946)

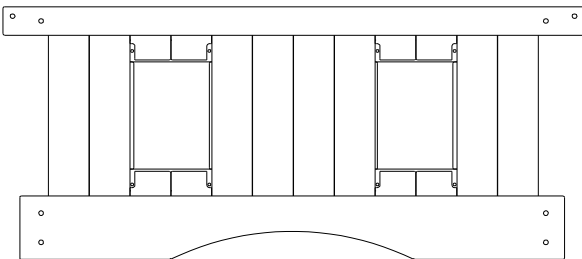

WP04 WALL PANEL - W2A05000
(x1) 2 1/16"x21"x48 7/16" (52x534x1230)

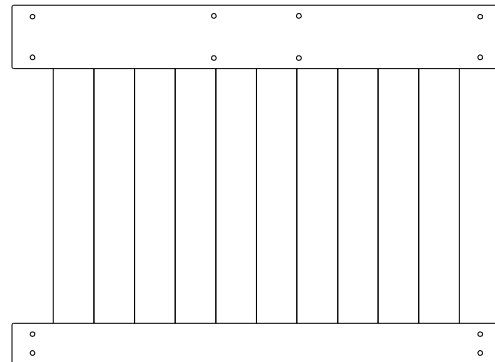

WP12 WALL PANEL - W2A04994
(x1) 1 13/16"x29 13/16"x40 11/16" (46x758x1034)

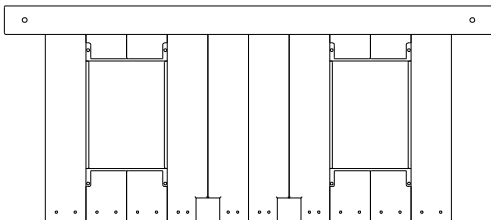

WP05 WALL PANEL - W2A04995
(x1) 2 1/16"x18 1/8"x40 11/16" (52x460x1034)

OWNER'S MANUAL - PARTS IDENTIFICATION

Wood Components (Not to Scale)

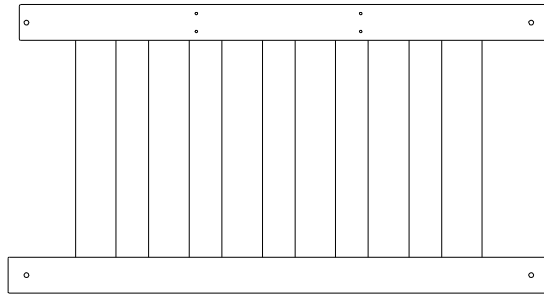

PP01 PICKET PANEL - W2A05009
(x1) 1 9/16"x24"x45 3/16" (40x610x1147)

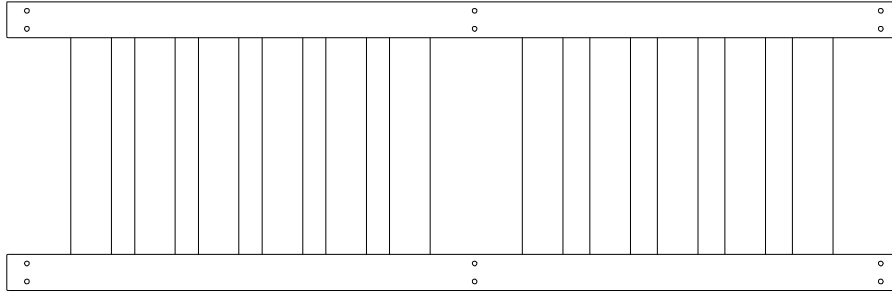

PP02 PICKET PANEL - W2A05010
(x1) 1 9/16"x24"x45 3/16" (40x610x1894)

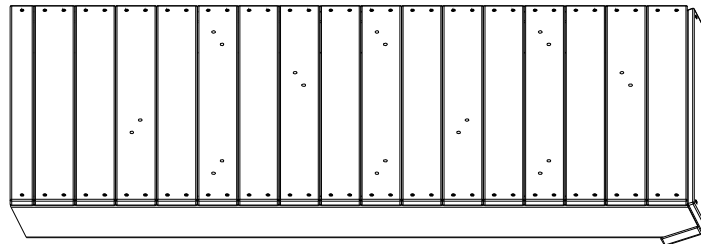

RW01 ROCK WALL - W2A05007
(x1) 4 7/8"x26 3/8"x58 1/4" (123x670x1479)

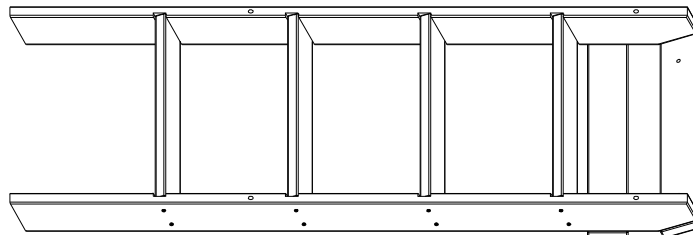

LD01 LADDER - W2A05006
(x1) 4 3/16"x23 1/8"x57 5/8" (107x588x1464)

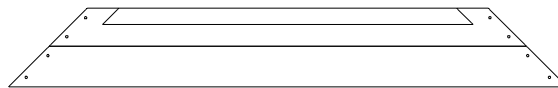

GP01 GABLE PANEL - W2A04296
(x2) 1 7/8"x6 9/16"x46 9/16" (48x166x1182)

OWNER'S MANUAL - PARTS IDENTIFICATION

Wood Components (Not to Scale)



RP01 ROOF PANEL - W2A04295
(x2) 1 5/8"x40 7/8"x49 3/16" (42x1038x1250)

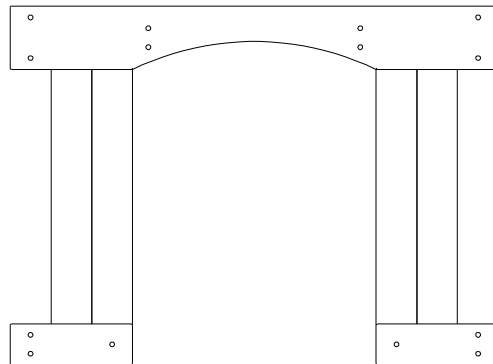

WP13 WALL PANEL - W2A04999
(x1) 1 9/16"x29 13/16"x40 11/16" (40x758x1034)

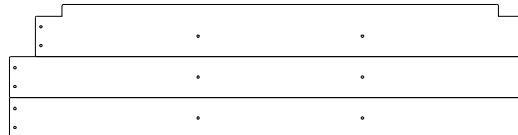

CT01 COUNTER TOP - W2A05008
(x1) 13/16"x11 1/8"x43 1/16" (21x283x1093)

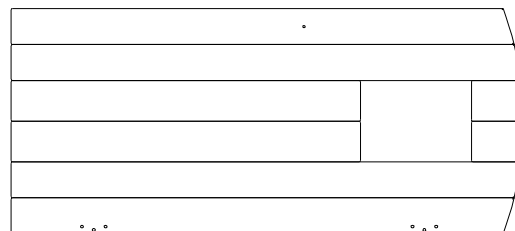

DP01 DOOR PANEL - W2A05005
(x1) 1 1/4"x18 3/4"x42 11/16" (32x476x1085)

OWNER'S MANUAL - PARTS IDENTIFICATION

Hardware Components

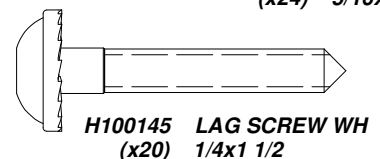
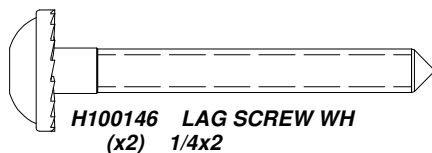
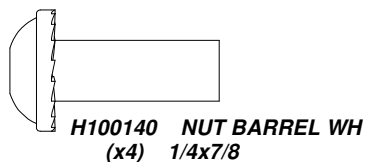
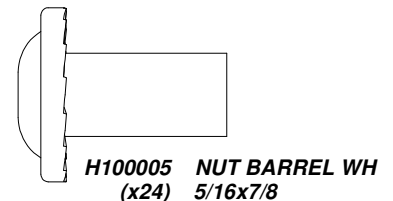
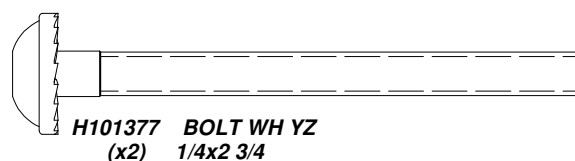
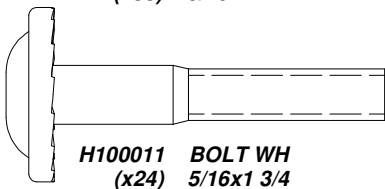
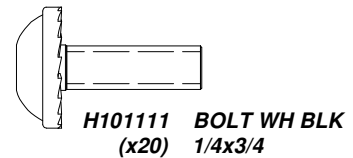
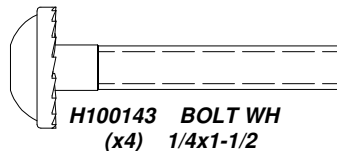
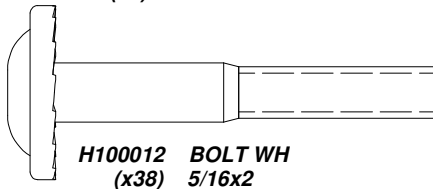
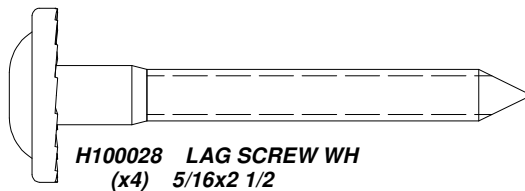
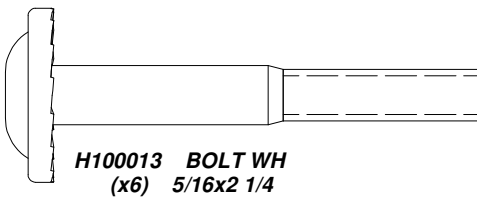
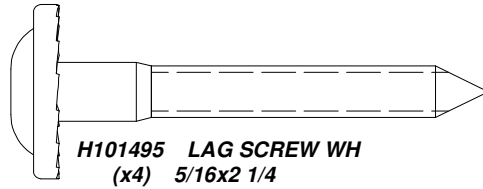
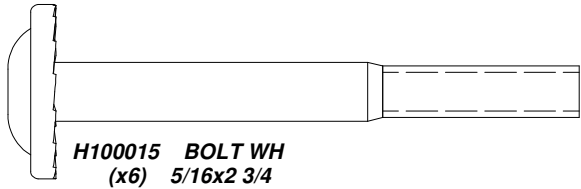
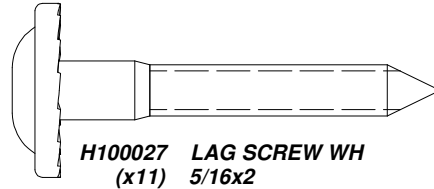
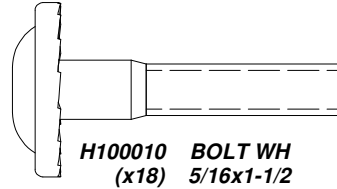
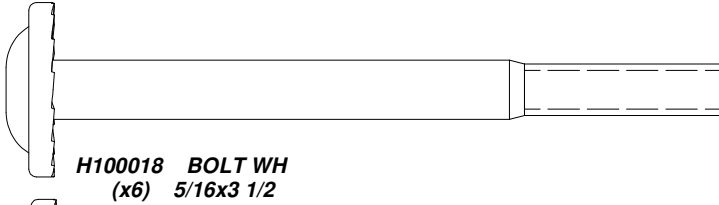
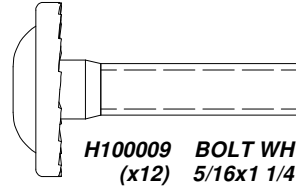
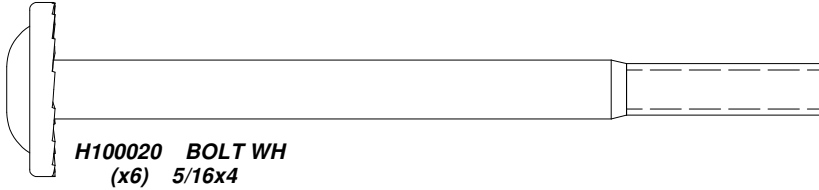
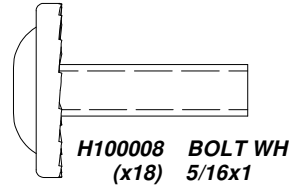
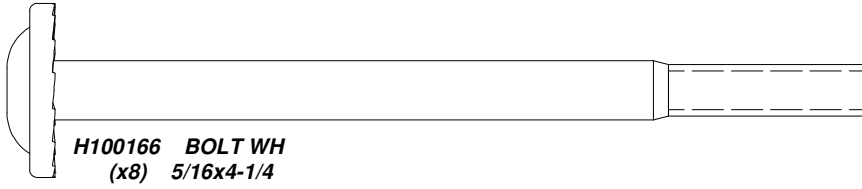
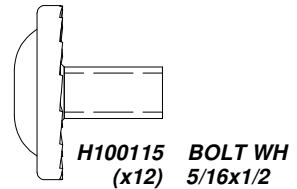
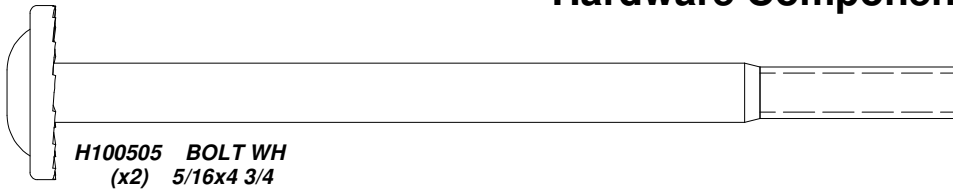

OWNER'S MANUAL - PARTS IDENTIFICATION

Hardware Components

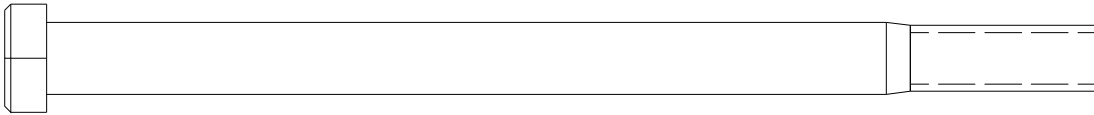

H100654 BOLT HEX
(x12) 3/8x5-1/2

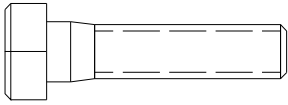

H100042 BOLT HEX
(x4) 5/16x1 1/4

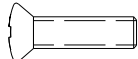

H101475 SCREW POH BLK
(x12) 8/32x5/8

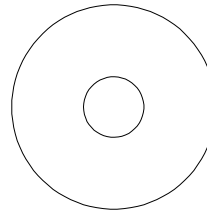

H100105 WASHER FLAT
(x4) 8x27

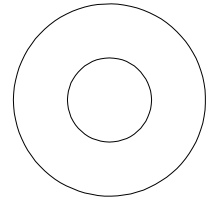

H100102 WASHER FLAT
(x12) 11x25

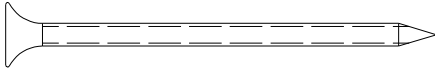

H100091 SCREW PFH
(x4) 8x2 1/4

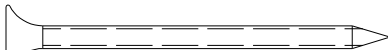

H100111 SCREW PFH
(x18) 8x2

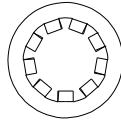

H100473 WASHER LOCK INT BLK
(x20) 8x15

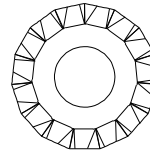

H100030 WASHER LOCK EXT
(x117) 8x19

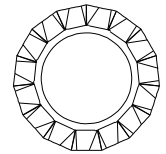

H100031 WASHER LOCK EXT
(x12) 12x19

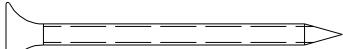

H100089 SCREW PFH
(x38) 8x1 3/4

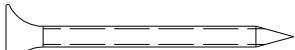

H100086 SCREW PFH
(x85) 8x1 1/2

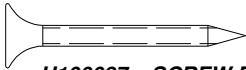

H100087 SCREW PFH
(x96) 8x1 1/4

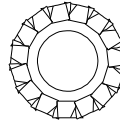

H100138 WASHER LOCK EXT
(x8) 6x15

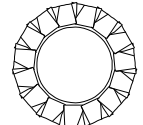

H100139 WASHER LOCK EXT
(x4) 8x15



H100181 SCREW PWH
(x24) 8 x 1-5/8

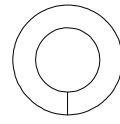

H100095 WASHER SPLIT
(x4) 5/16

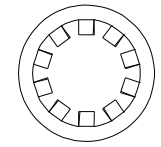

H100107 WASHER LOCK INT
(x12) 10x18

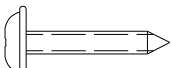

H100070 SCREW PWH
(x16) 8x3/4

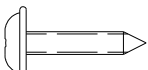

H100202 SCREW PWH BLK
(x4) 8x5/8

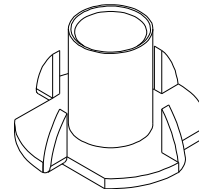

H100073 T-NUT
(x12) 3/8

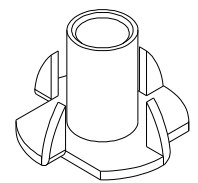

H100074 T-NUT
(x150) 5/16

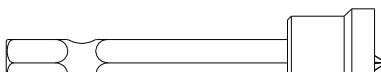

H100764 SCREW SETTER
(x1)

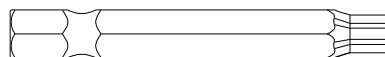

H100147 T-30 TORX BIT
(x1)

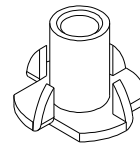

H100072 T-NUT
(x2) 1/4

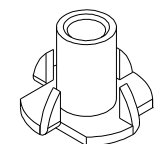

H100398 T-NUT BLK
(x20) 1/4

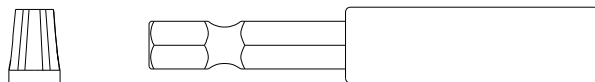

H101100 MAGNETIC DRIVER
(x1)

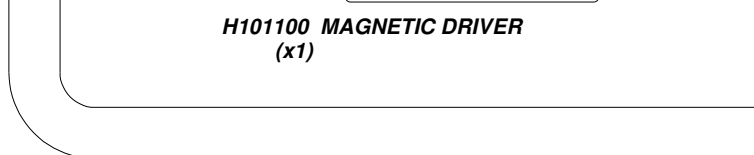

H100114 T-30 TORX WRENCH
(x1)

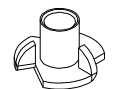

H100804 T-NUT
(x12) 8/32

OWNER'S MANUAL - PARTS IDENTIFICATION

Accessory Components (Not to Scale)

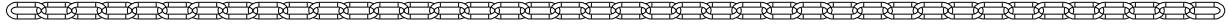

A100068 CHAIN GREEN 51.25"
(x4)

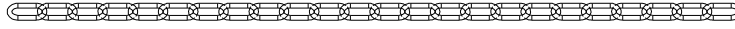

A100177 CHAIN GREEN 31"
(x2)

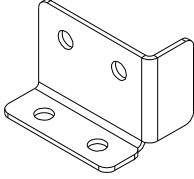

A4M05883 SADDLE BRACKET - RIGHT
(x1)

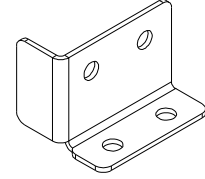

A4M05884 SADDLE BRACKET - LEFT
(x1)

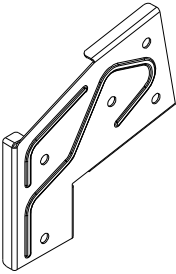

A100326 SWING BEAM EXTENSION
(x1) BRACKET-RIGHT

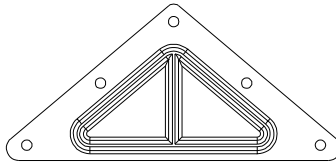

A100294 TRIANGLE PLATE 100° 5 HOLE
(x2)

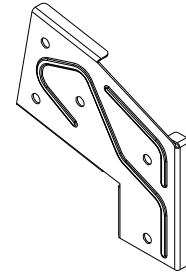

A100325 SWING BEAM EXTENSION
(x1) BRACKET-LEFT



A4M03403 BYD ID TAG LARGE
(x1)

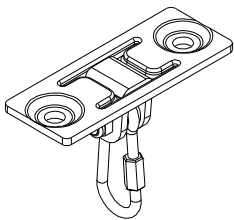

A4M00505 SWING HANGER
(x6)

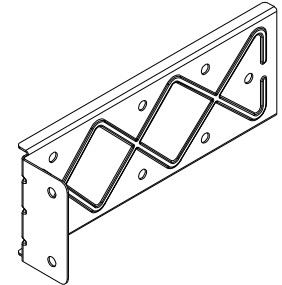

A4M00993 EXTENDED SWING BEAM
(x2) BRACKET

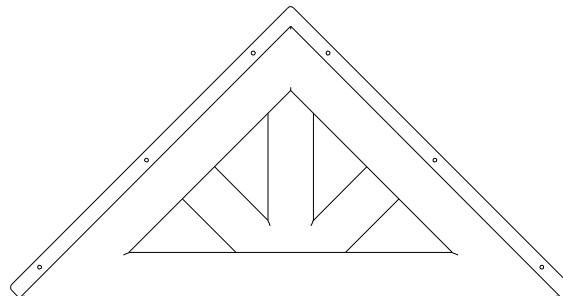

A100331 PLASTIC GABLE
(x2)

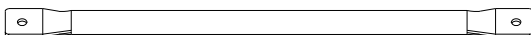

A100045 METAL RUNG 559 GREEN
(x8)

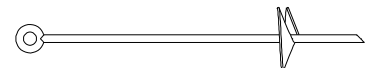

A100178 AUGER GROUND STAKE
(x8)

OWNER'S MANUAL - PARTS IDENTIFICATION

Accessory Components (Not to Scale)

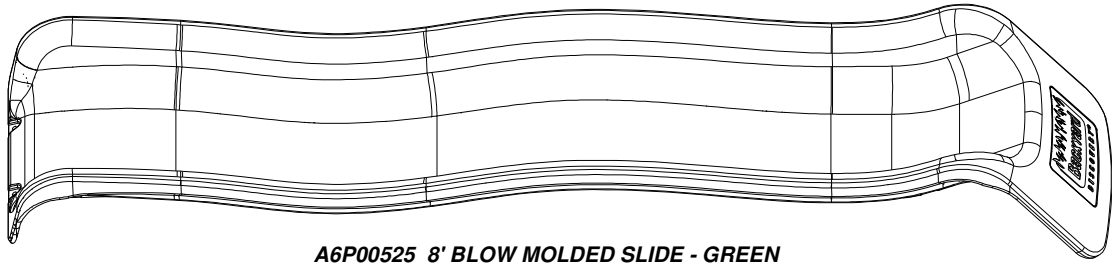

A6P00525 8' BLOW MOLDED SLIDE - GREEN
(x1)



A6P00054 SWING SEAT GREEN 22"
(x2)

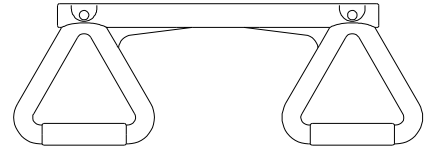

A6P00034 TRAPEZE YELLOW
(x1)

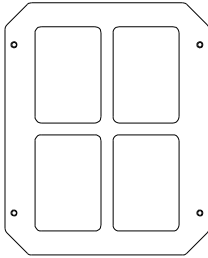

A100014 PLASTIC WINDOW WHITE
(x1)

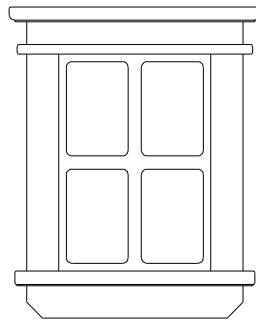

A100320 PLASTIC WINDOW 44x266x329
(x6)

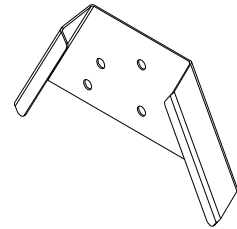

A4M01169 A-FRAME BRACKET
(x1)

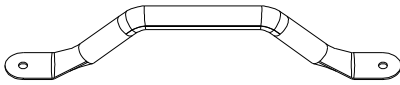

A100118 HAND GRIP METAL GREEN 381 c/c
(x6)



A100327 HINGE (DOOR, SPRING LOADED)
(x2)

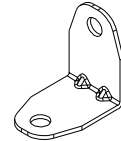

A4M01046 L BRACKET 2.5x38x55x55
(x8)

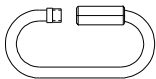

A100069 QUICK LINK
(x6)

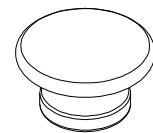

A6P00274 KNOB
(x1)



A100134 HAND GRIP GREEN 816 C/C
(x2)

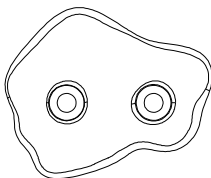

A6P00037 GREEN HC ROCK #2
(x5)

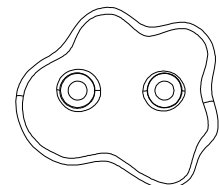

A6P00036 GREEN HC ROCK #1
(x5)

PRE-ASSEMBLY STEP 1 - SORTING PARTS

It is critical for ease of assembly that you take the time to sort and organize the wood and hardware.

WOOD PARTS:

- Organize wood parts by the three-digit, alpha-numeric number stamped on each board (ex. P01).
- If there are multiple boards with the same stamped number, stack those pieces together.
- Stamps can be found on the flat surface of the boards or on the end of the boards.
- Allow yourself plenty of room - the wood pieces can take up a significant amount of space.

NOTE: CARTONS ARE NOT ORGANIZED BY BOARD NUMBER.

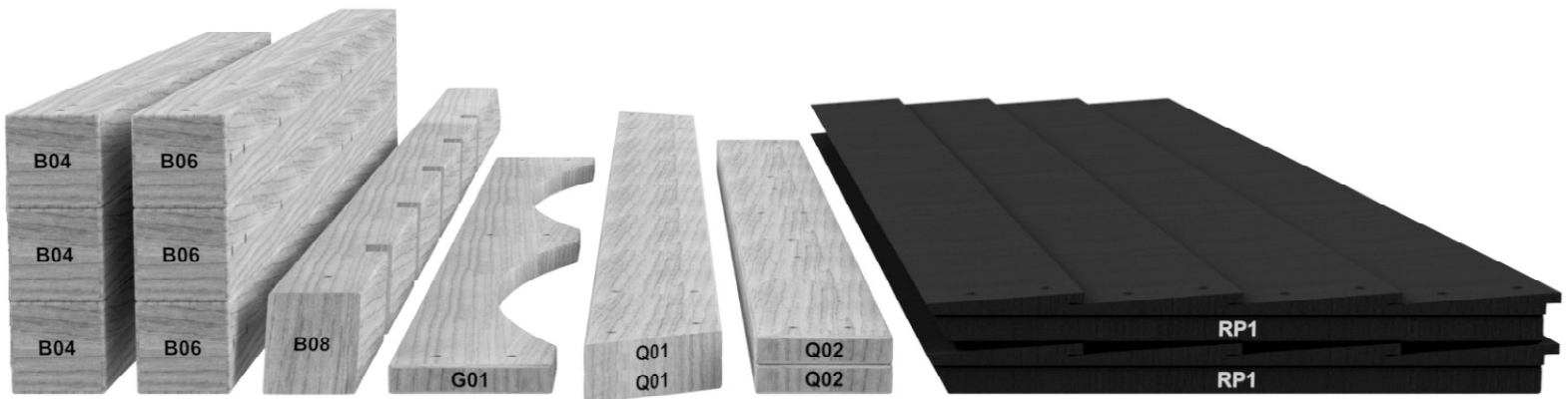

HARDWARE PARTS:

- We recommend that you have a separate table to organize the hardware.
- Hardware bags are printed with a seven-digit, alpha-numeric part number.
- You can organize your hardware by part number or group by hardware type (i.e. bolts, nuts, etc.).
- During assembly you only need to reference the last four digits of the number.

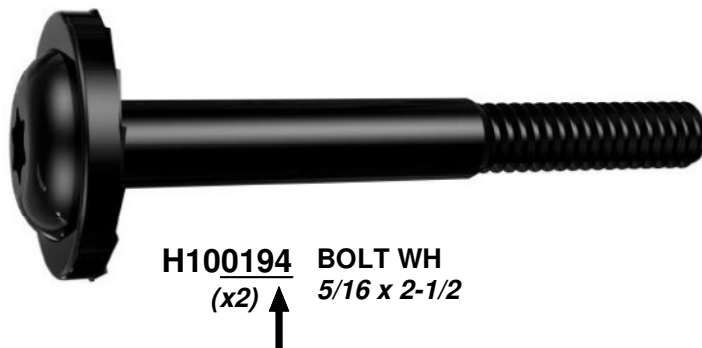

PRE-ASSEMBLY STEP 2 - TOOLS REQUIRED



**Cordless Drill or
Electric Drill**



**Drill Attachments:
Phillips Head**



**1/8", 3/16", 3/8" & 7/16"
Drill Bits**



Phillips Screw Driver



Open End Wrenches 1/2" & 9/16"



**3/8" Drive Ratchet, 1/2" &
9/16" STD Sockets 1/2" & 9/16" Deep
Sockets**



Claw Hammer



Rubber Mallet - Optional



Tape Measure

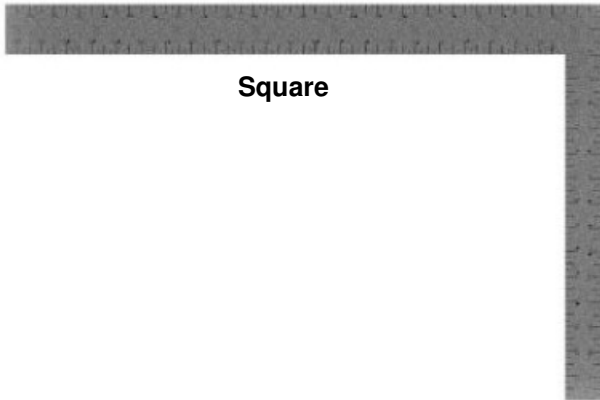

Square



Level 24"

PRE-ASSEMBLY STEP 3 - CHOOSE YOUR ASSEMBLY METHOD

There are several types of assembly instructions available to you.

1. Printed Assembly Manual included with your set
2. BILT APP - 3D interactive instructions
3. Combination of the Printed Manual and BILT APP (Note: Step numbers can differ between the two methods)





SCAN FOR **BILT**. 3D INSTRUCTIONS



POWERED BY **BILT INTELLIGENT INSTRUCTIONS**®

**Scan for easy
3D instructions**

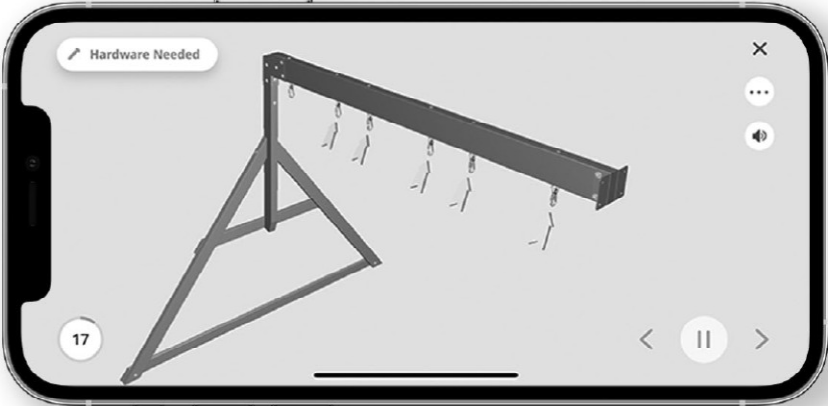
Download the BILT app
before you begin



STEP 1 - MONKEY BARS

QTY	PART NUMBER	DESCRIPTION
4	H100005	NUT BARREL WH 5/16x7/8
4	H100008	BOLT WH 5/16x1
6	H100010	BOLT WH 5/16x1 1/2
4	H100031	WASHER LOCK EXT 12x19
6	H100074	T-NUT 5/16
8	H100145	LAG SCREW WH 1/4x1-1/2

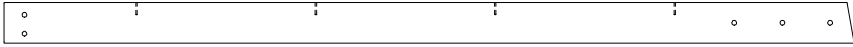

E74 MONKEY BAR RAIL - W4L22166
(x2) 1 3/8"x3 3/8"x70 7/8" (36x86x1800)

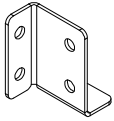

A4M05883 SADDLE BRACKET
(x1) - RIGHT

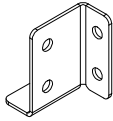

A4M05884 SADDLE BRACKET
(x1) - LEFT

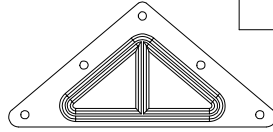

A100294 TRIANGLE PLATE
(x2) 100° 5 HOLE

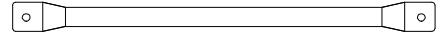

A100045 METAL RUNG 559
(x4) GREEN

INSTALL T-NUTS IN WOOD FIRST ALIGN PILOT HOLES

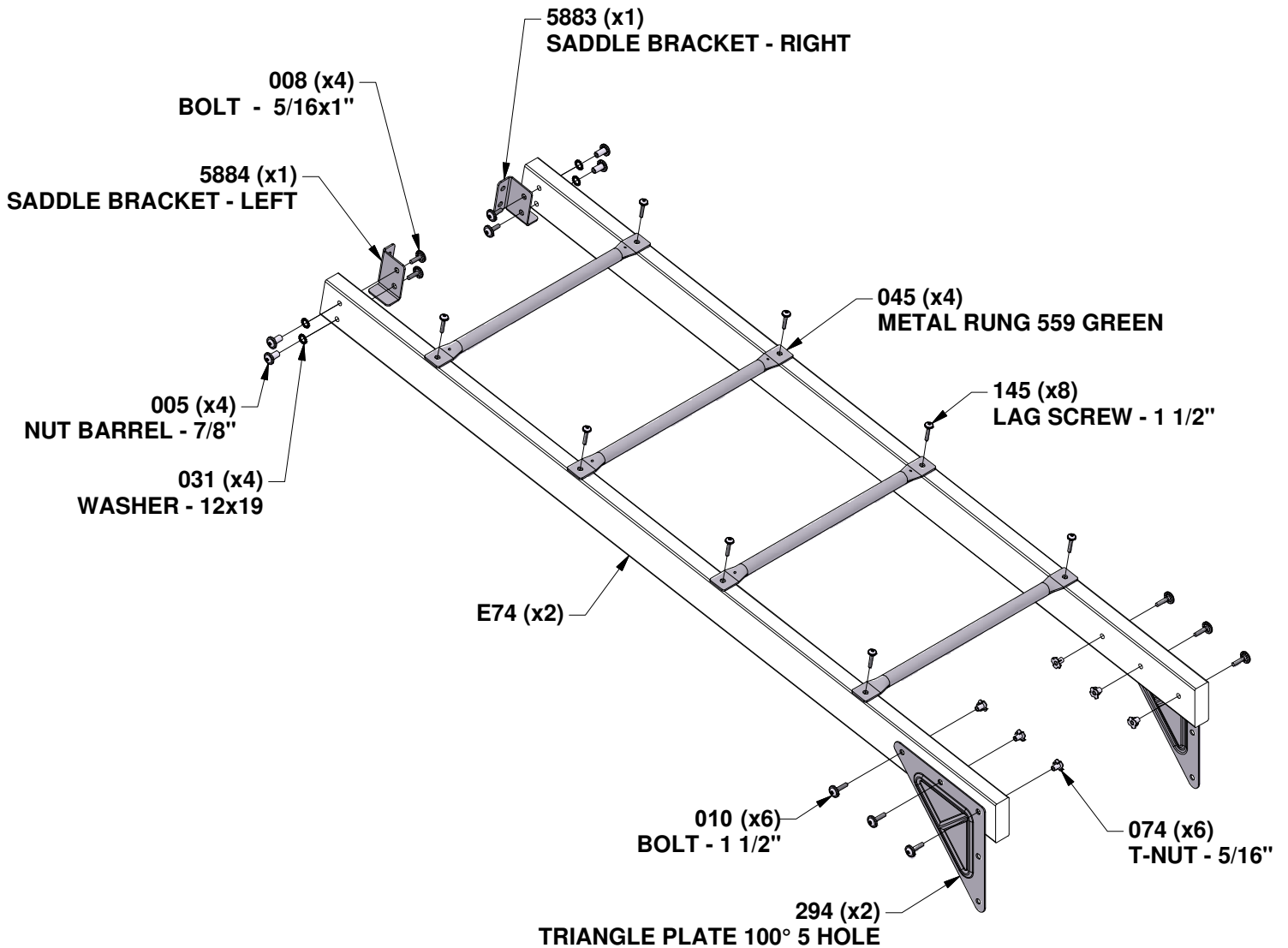

STEP 2 - MONKEY BARS

QTY	PART NUMBER	DESCRIPTION
4	H100010	BOLT WH 5/16x1 1/2
4	H100074	T-NUT 5/16



E13 MONKEY BAR UPRIGHT - W4L22163
(x2) 1 3/8"x3 3/8"x80 3/8" (36x86x2043)

INSTALL T-NUTS IN WOOD FIRST

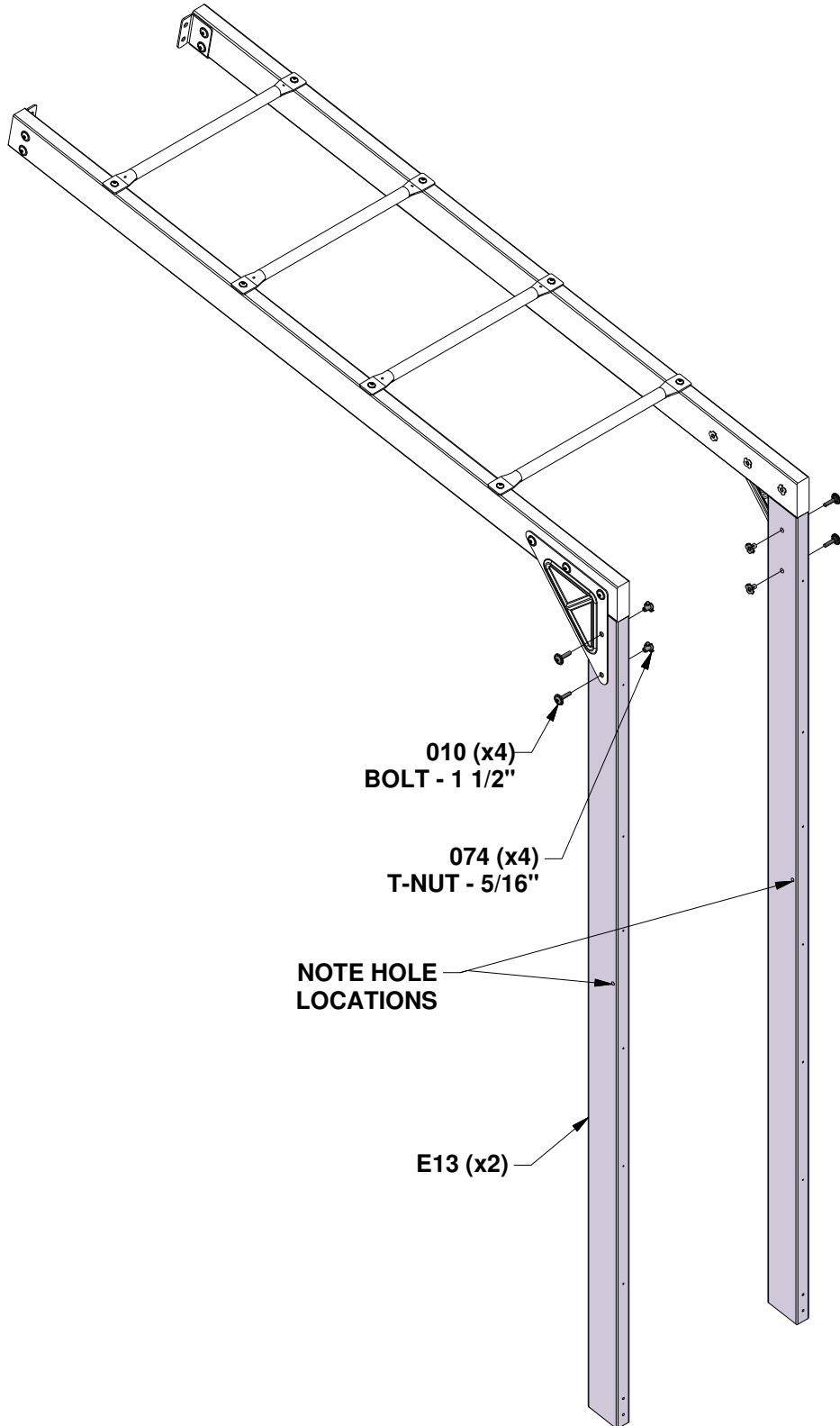

STEP 3 - MONKEY BARS

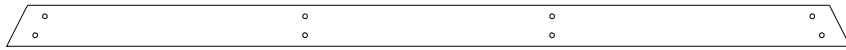

H82 MONKEY BAR GROUND BOARD - W4L22165
(x1) 1"x3 3/8"x70 3/8" (24x86x1786)

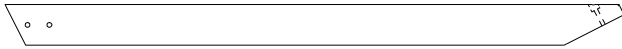

H81 MONKEY BAR BRACE - W4L22164
(x2) 1"x3 3/8"x51 5/8" (24x86x1311)

QTY	PART NUMBER	DESCRIPTION
4	H100011	BOLT WH 5/16x1 3/4
4	H100028	LAG SCREW WH 5/16x2 1/2
8	H100030	WASHER LOCK EXT 8x19
2	H100072	T-NUT 1/4
4	H100074	T-NUT 5/16
2	H100138	WASHER LOCK EXT 6x15
2	H101377	BOLT WH 1/4x2 3/4

INSTALL T-NUTS IN WOOD FIRST

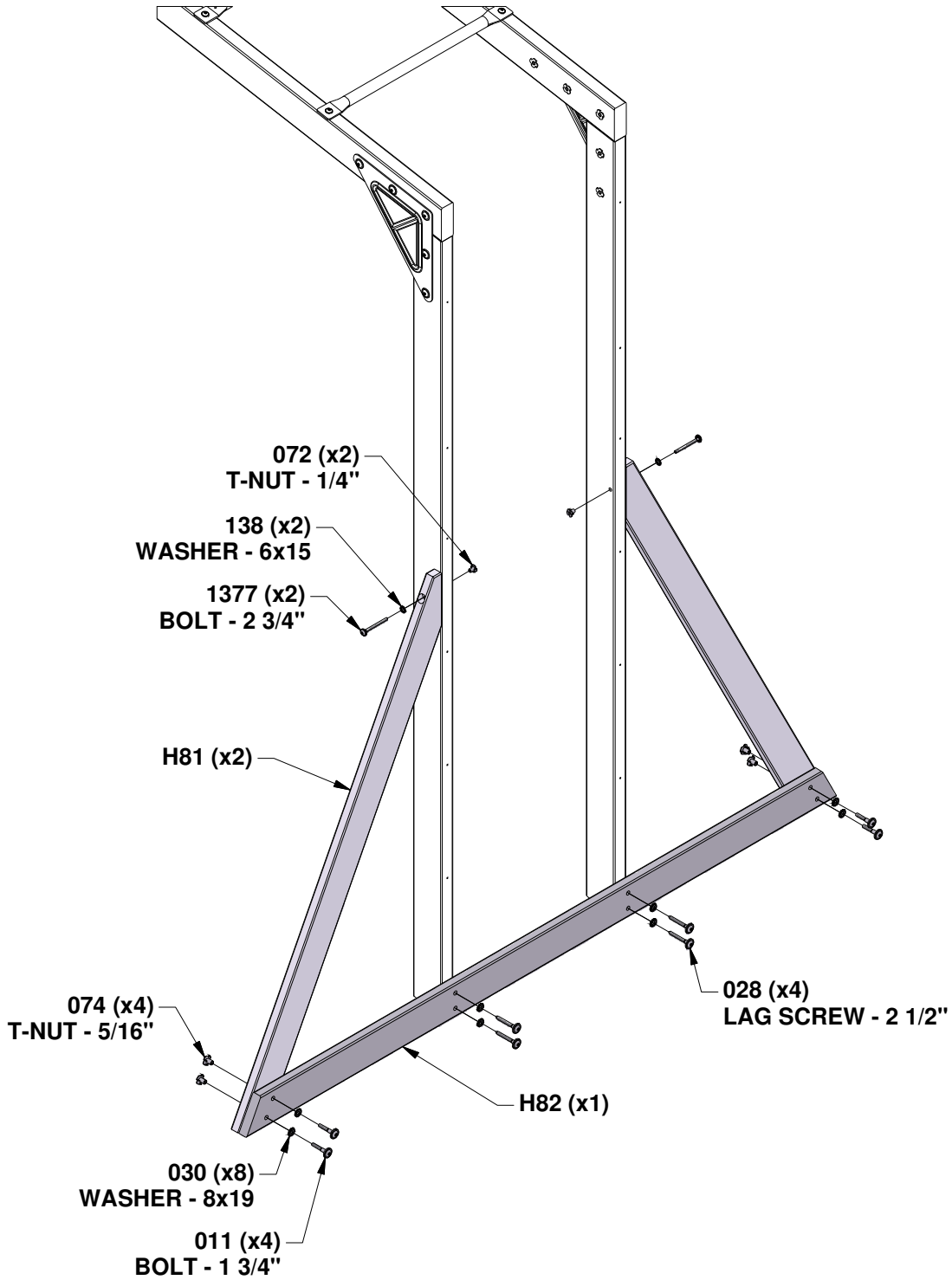

STEP 4 - MONKEY BARS

QTY	PART NUMBER	DESCRIPTION
12	H100145	LAG SCREW WH 1/4x1-1/2

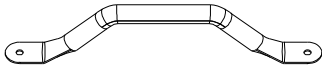

A100118 HAND GRIP METAL
(x2) GREEN 381 c/c

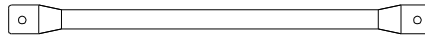

A100045 METAL RUNG 559
(x4) GREEN

ALIGN PILOT HOLES

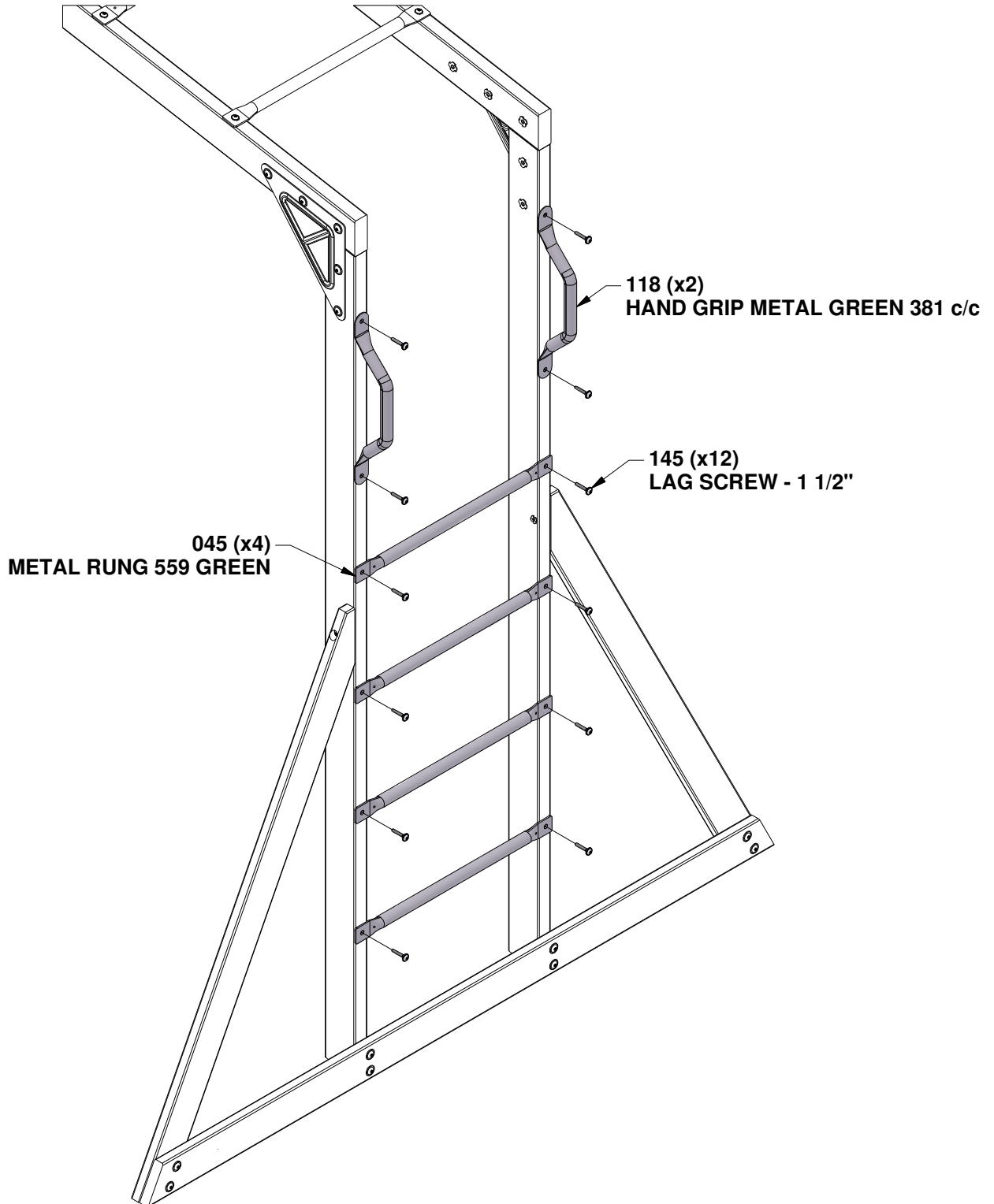

STEP 1 - SWING BEAM ASSEMBLY

QTY	PART NUMBER	DESCRIPTION
10	H100005	NUT BARREL WH 5/16x7/8
10	H100016	BOLT WH 5/16x3



A01 SWING BEAM - W4L22161
(x1) 3 3/8"x5 1/4"x89 1/2" (86x134x2274)



A02 SB 9" BLOCK - W4L22162
(x1) 3 3/8"x5 1/4"x9" (86x134x228)

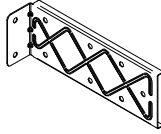

A4M00993 EXTENDED SWING BEAM BRACKET
(x2)

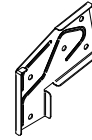

A100325 SWING BEAM EXTENSION BRACKET-LEFT
(x1)

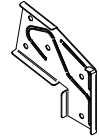

A100326 SWING BEAM EXTENSION BRACKET-RIGHT
(x1)

LEAVE 016 BOLTS & 005 NUT BARRELS HAND TIGHT.

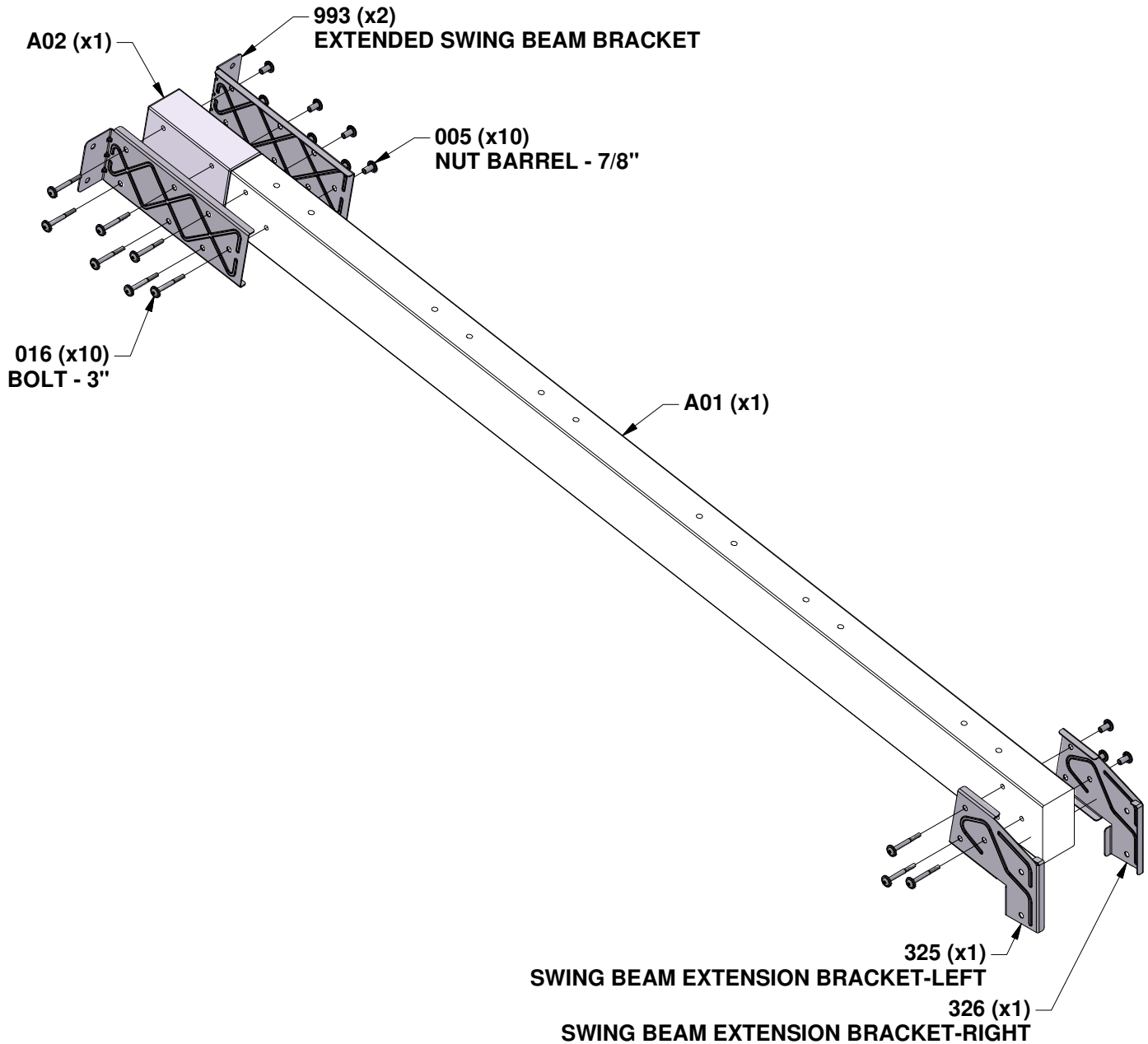
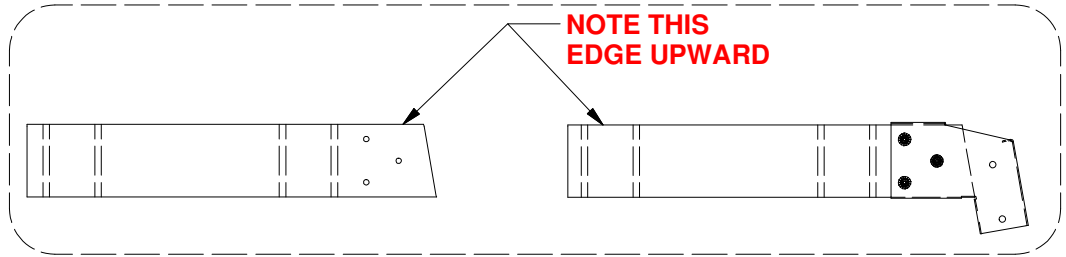

STEP 2 - SWING BEAM ASSEMBLY

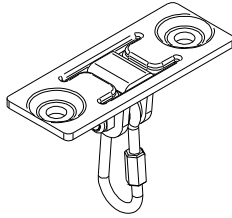

**A4M00505 SWING HANGER
(x6)**

QTY	PART NUMBER	DESCRIPTION
12	H100073	T-NUT 3/8
12	H100102	WASHER FLAT 11x25
12	H100107	WASHER LOCK INT 10x18
12	H100654	BOLT HEX 3/8x5-1/2

INSTALL T-NUTS IN WOOD FIRST

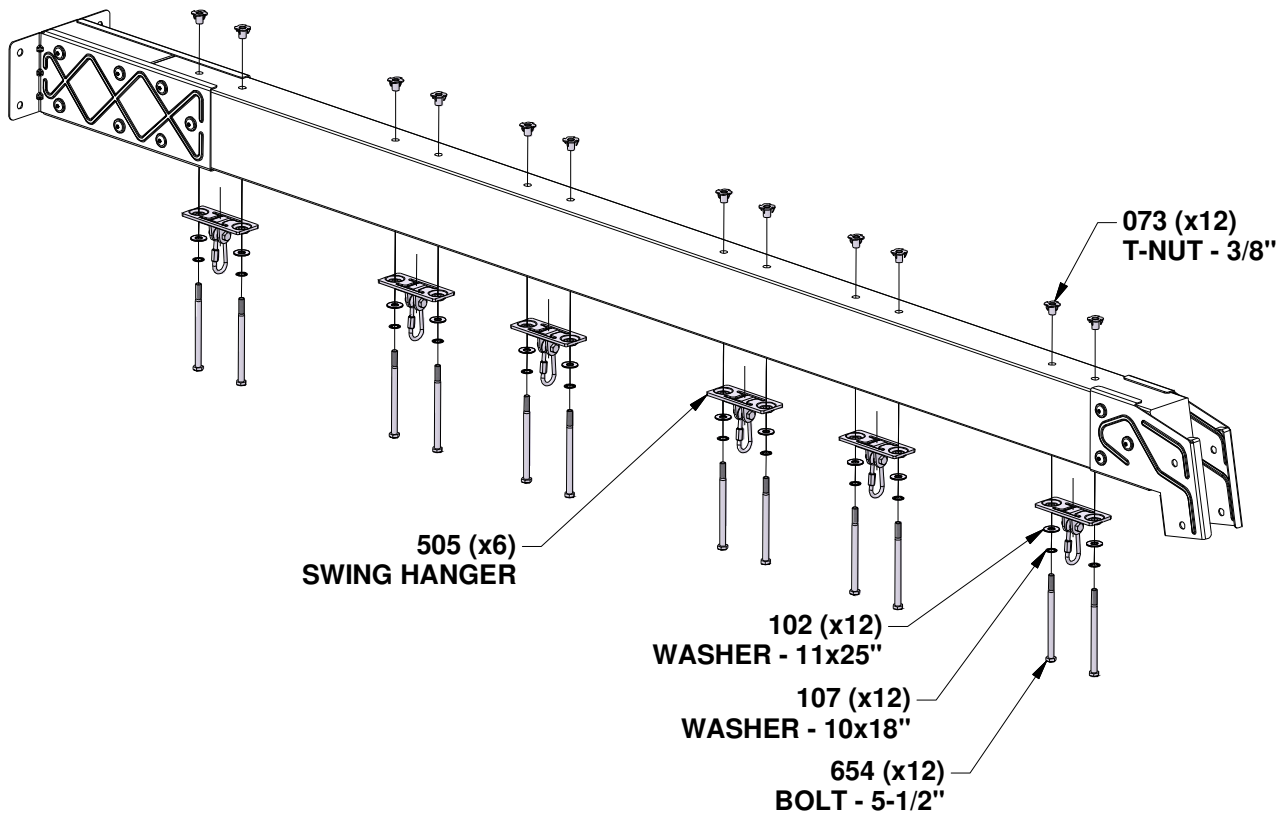

STEP 3 - SWING BEAM ASSEMBLY

QTY	PART NUMBER	DESCRIPTION
4	H100202	SREW PWH 8x5/8" BLK



A4M03403 BYD ID TAG LARGE
(x1)

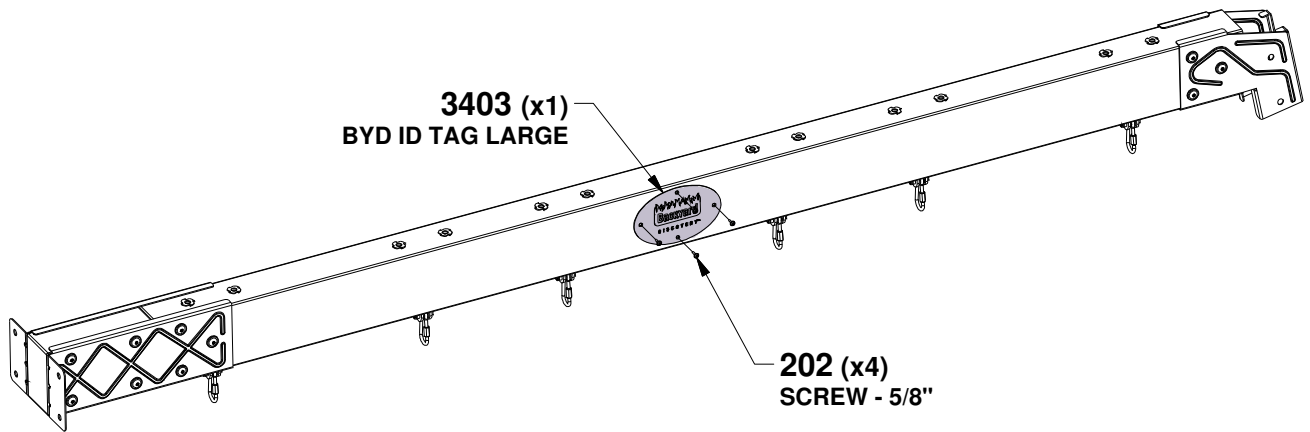
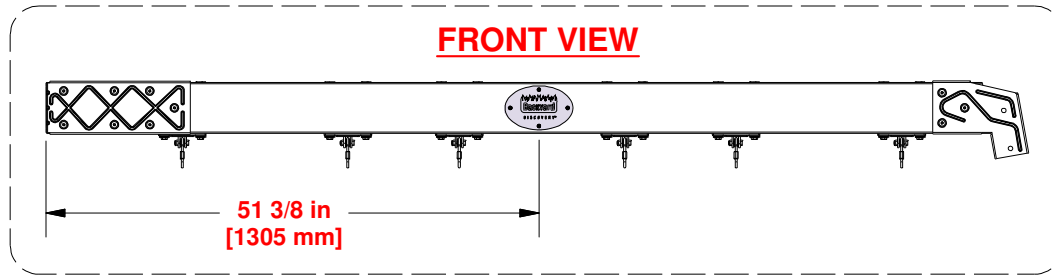

STEP 4 - SWING BEAM ASSEMBLY

QTY	PART NUMBER	DESCRIPTION
4	H100010	BOLT WH 5/16x1 1/2
2	H100018	BOLT WH 5/16x3 1/2
6	H100074	T-NUT 5/16



SP71 SWING BEAM SUPPORT - W4L22160
(x1) 3 3/8"x3 3/8"x46 1/4" (86x86x1176)

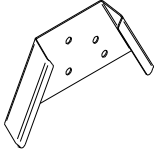

A4M01169 A-FRAME
(x1) **BRACKET**



E80 ANGLE BRACE - W4L22158
(x2) 1 3/8"x3 3/8"x83" (36x86x2108)

INSTALL T-NUTS IN WOOD FIRST

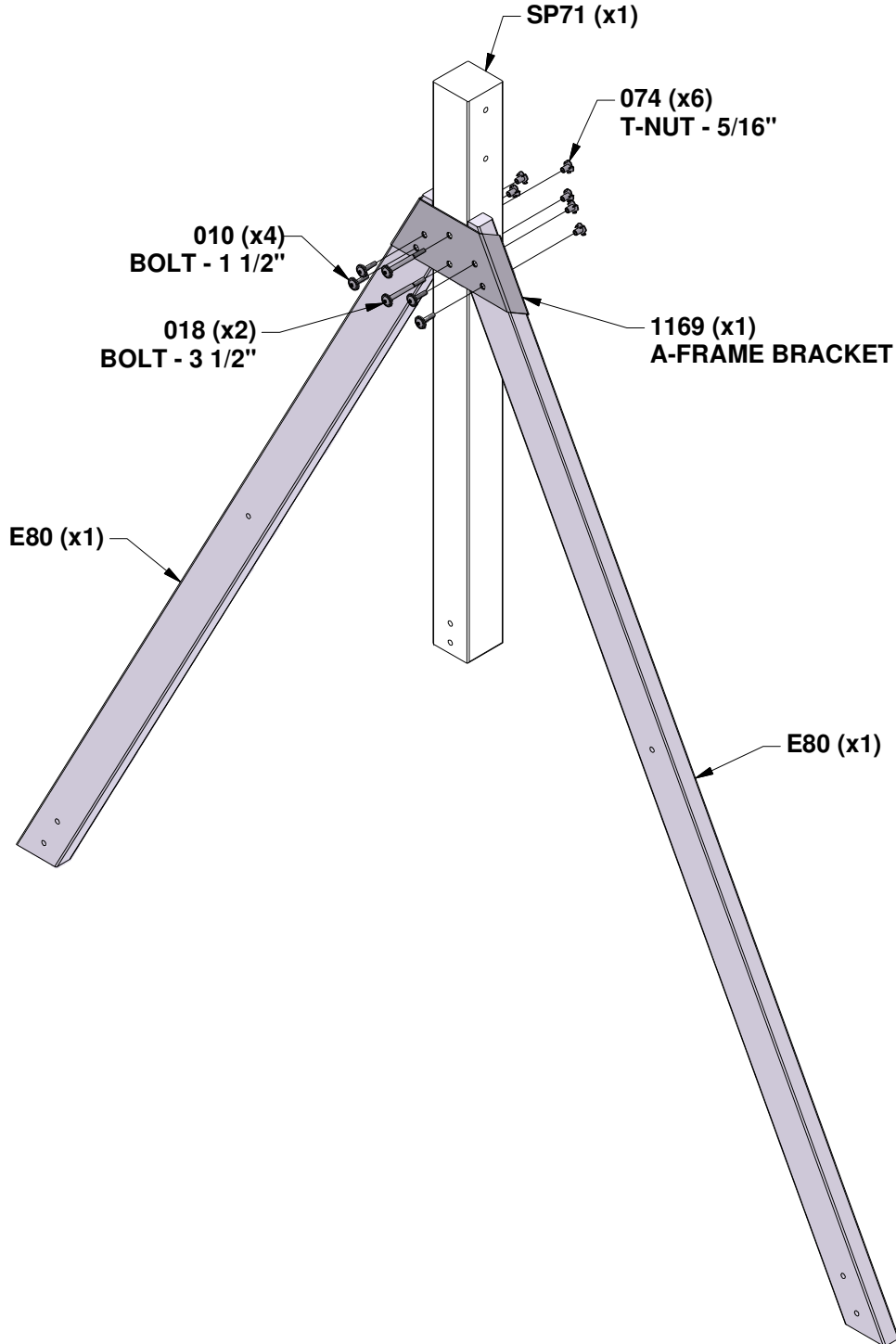

STEP 5 - SWING BEAM ASSEMBLY

QTY	PART NUMBER	DESCRIPTION
4	H100013	BOLT WH 5/16x2 1/4
2	H100015	BOLT WH 5/16x2 3/4
8	H100030	WASHER LOCK EXT 8x19
8	H100074	T-NUT 5/16
2	H100505	BOLT WH 5/16x4 3/4

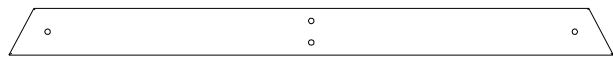

E79 END SUPPORT - W4L22159
(x1) 1 1/2"x3 1/2"x44" (36x86x1120)



G50 GROUND BOARD - W4L22157
(x1) 1"x5 1/4"x82 13/16" (24x134x2104)

INSTALL T-NUTS IN WOOD FIRST

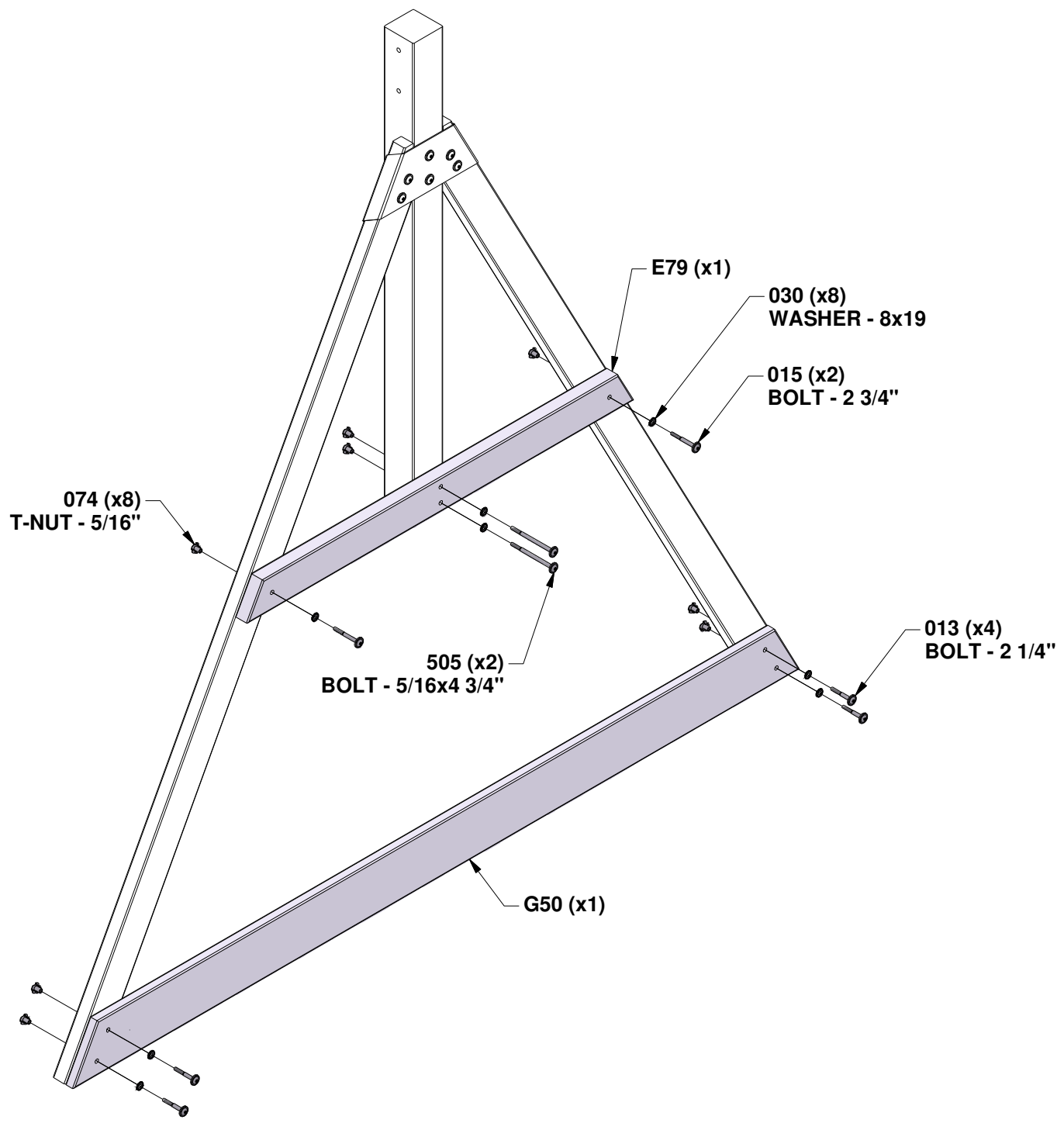

STEP 6 - SWING BEAM ASSEMBLY

QTY	PART NUMBER	DESCRIPTION
2	H100005	NUT BARREL WH 5/16x7/8
2	H100016	BOLT WH 5/16x3

TIGHTEN ALL 016 BOLTS & 005 NUT BARRELS NOW.

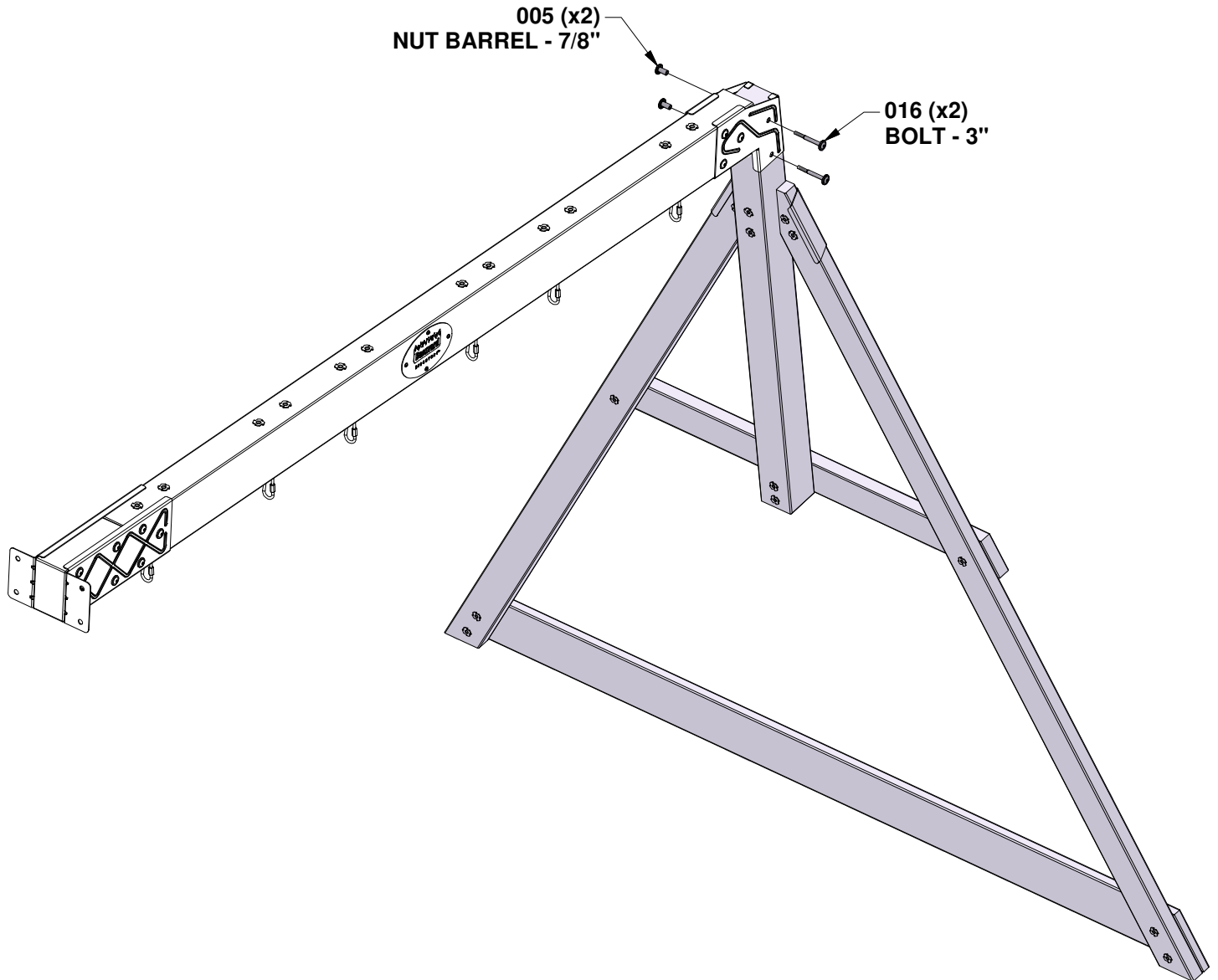

STEP 1 - LADDER

QTY	PART NUMBER	DESCRIPTION
4	H100018	BOLT WH 5/16x3 1/2
4	H100074	T-NUT 5/16

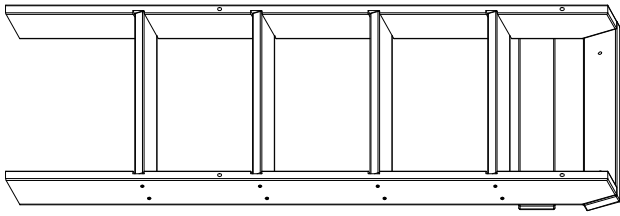

LD01 LADDER - W2A05006
(x1)



A100134 HAND GRIP GREEN 816 C/C
(x2)

INSTALL T-NUTS IN WOOD FIRST

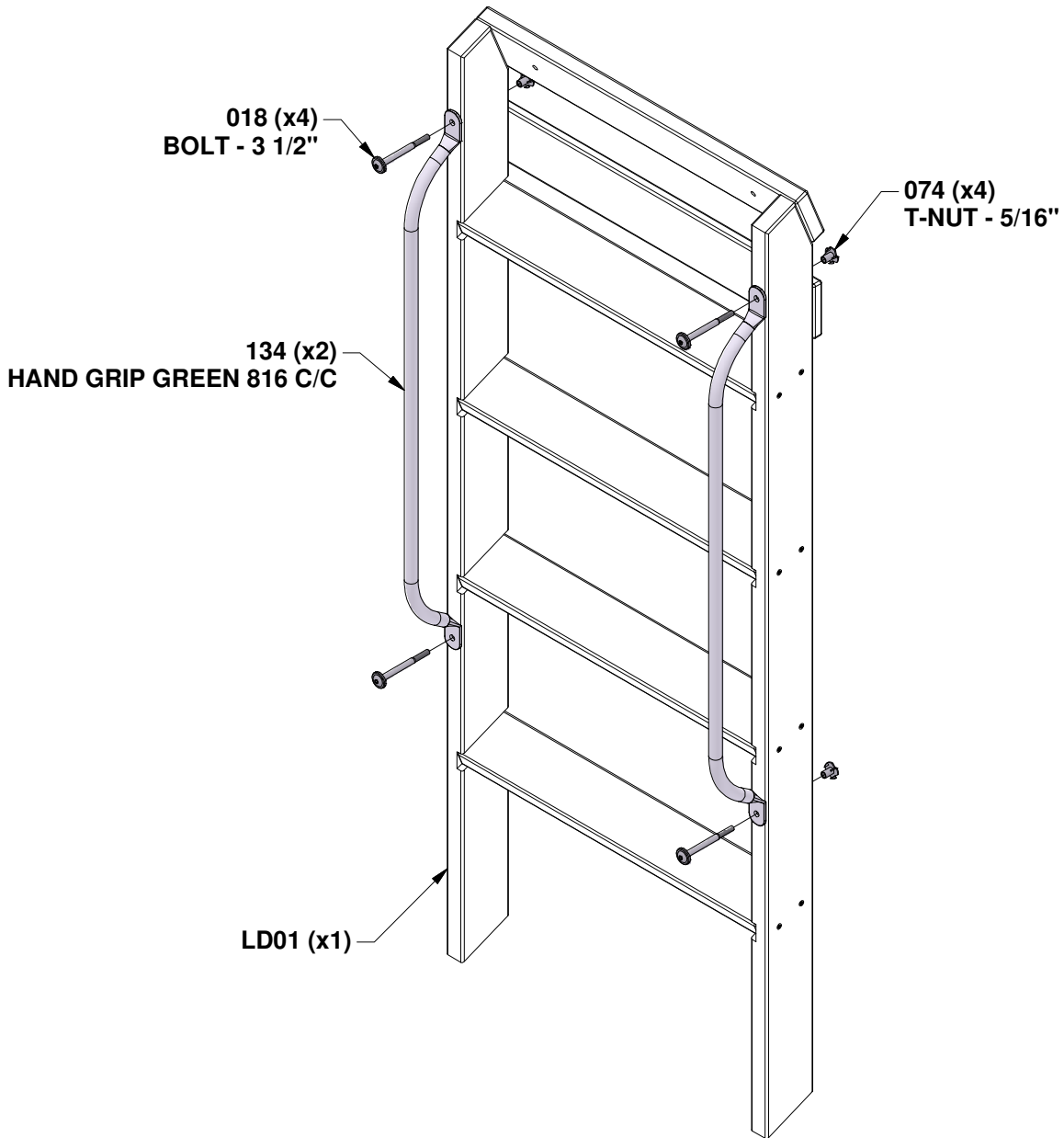

STEP 1 - ROCK WALL

QTY	PART NUMBER	DESCRIPTION
20	H100398	T-NUT 1/4
20	H100473	WASHER LOCK INT 8x15 BLK
20	H101111	BOLT WH 1/4x3/4 BLK

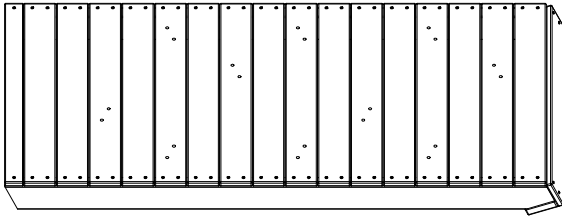

RW01 ROCK WALL - W2A05007
(x1)



A6P00036 GREEN HC ROCK #1
(x5)



A6P00037 GREEN HC ROCK #2
(x5)

INSTALL T-NUTS IN WOOD FIRST

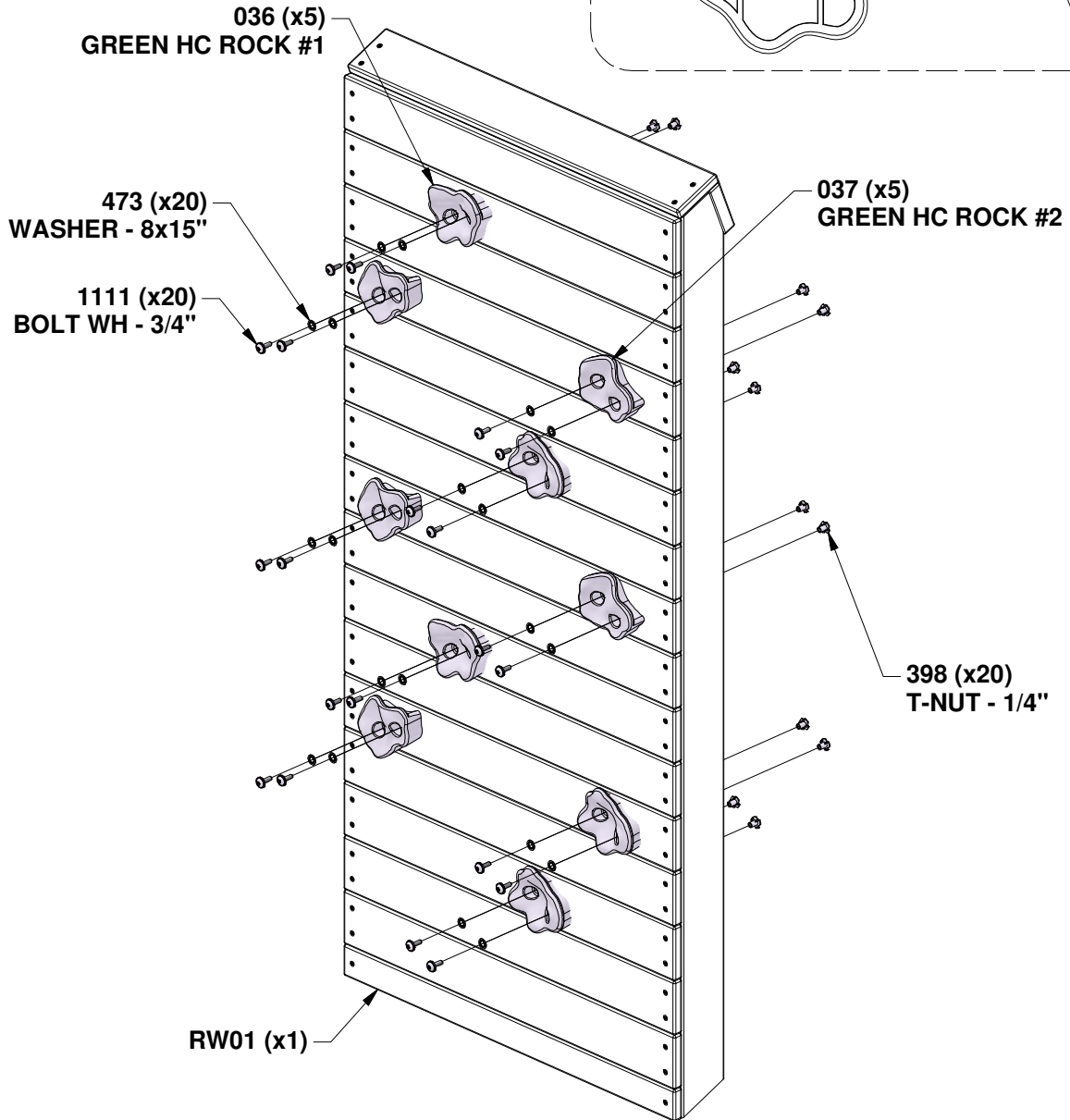
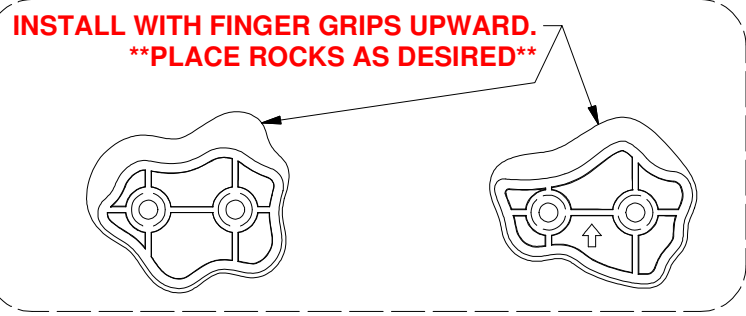

STEP 1 - FORT ASSEMBLY

QTY	PART NUMBER	DESCRIPTION
12	H100012	BOLT WH 5/16x2
12	H100030	WASHER LOCK EXT 8x19
12	H100074	T-NUT 5/16

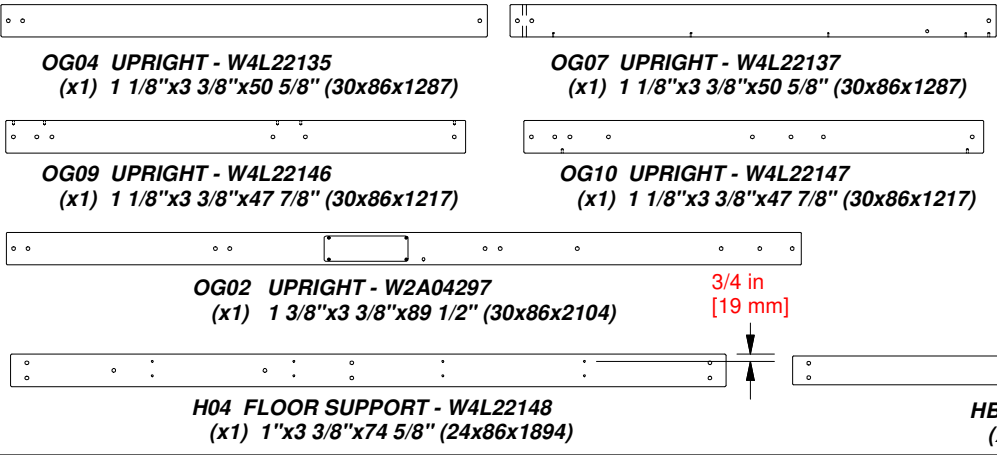

**INSTALL T-NUTS IN WOOD FIRST
NOTE PILOT HOLE POSITIONS BELOW**

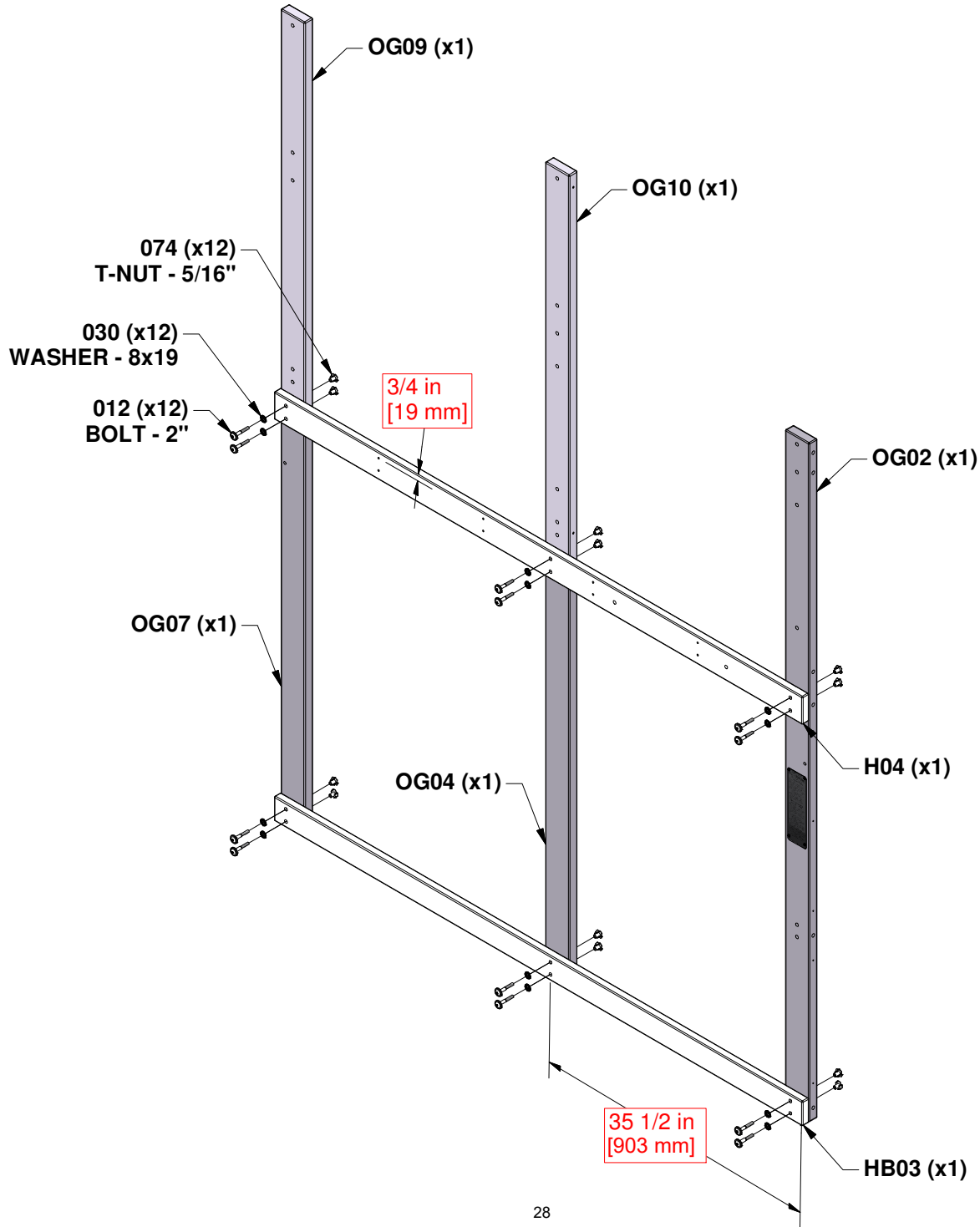

STEP 2 - FORT ASSEMBLY

QTY	PART NUMBER	DESCRIPTION
16	H100012	BOLT WH 5/16x2
2	H100016	BOLT WH 5/16x3
18	H100030	WASHER LOCK EXT 8x19
18	H100074	T-NUT 5/16

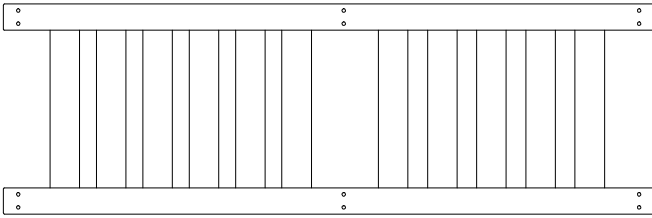

PP02 PICKET PANEL - W2A05010
(x1) 1 9/16"x24"x45 3/16" (40x610x1894)

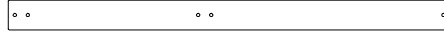

OG03 UPRIGHT - W4L22134
(x1) 1 1/8"x3 3/8"x50 5/8" (30x86x1287)



OG01 UPRIGHT - W4L22133
(x1) 1 1/8"x3 3/8"x82 7/8" (30x86x2104)



OG05 UPRIGHT - W4L22144
(x1) 1 1/8"x3 3/8"x47 7/8" (30x86x1217)

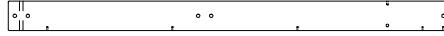

OG06 LOWER UPRIGHT - W4L22136
(x1) 1 1/8"x3 3/8"x50 5/8" (30x86x1287)

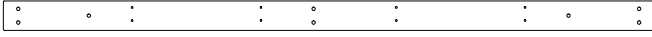

H03 FLOOR SUPPORT - W4L22139
(x1) 1"x3 3/8"x74 5/8" (24x86x1894)



OG08 UPRIGHT - W4L22145
(x1) 1 1/8"x3 3/8"x47 7/8" (30x86x1217)

HB08 CLEAT - W4L22172
(x1) 1"x3"x3 3/8" (24x76x86)

**INSTALL T-NUTS IN WOOD FIRST
NOTE PILOT HOLE POSITIONS BELOW**

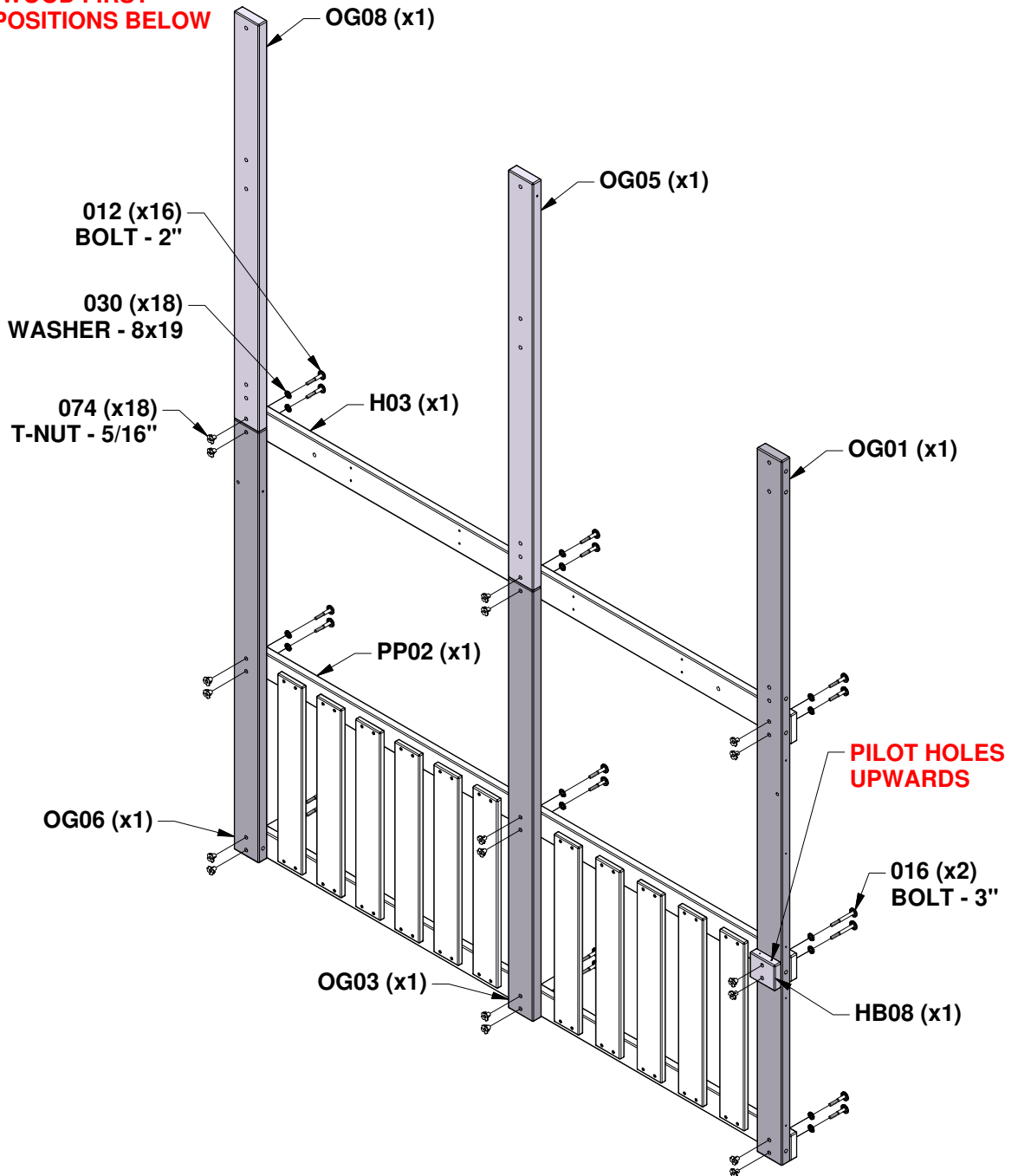

STEP 3 - FORT ASSEMBLY

QTY	PART NUMBER	DESCRIPTION
4	H101495	LAG SCREW WH 5/16x2 1/4
12	H100030	WASHER LOCK EXT 8x19
8	H100074	T-NUT 5/16
8	H100166	BOLT WH 5/16x4-1/4

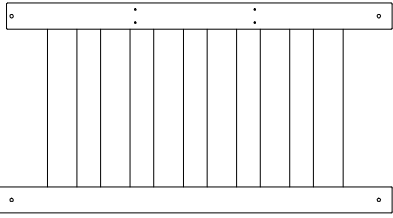

PP01 PICKET PANEL - W2A05009
(x1) 1 9/16"x24"x45 3/16" (40x610x1147)



H01 FLOOR SUPPORT - W4L22142
(x1) 1"x3 3/8"x45 1/8" (24x86x1147)

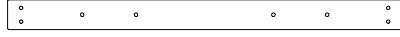

H06 FLOOR SUPPORT - W4L22143
(x1) 1"x3 3/8"x45 1/8" (24x86x1147)



HB01 GROUND BOARD - W4L22130
(x1) 1"x3"x45 1/8" (24x76x1147)

**INSTALL T-NUTS IN WOOD FIRST.
ALIGN PILOT HOLES.**

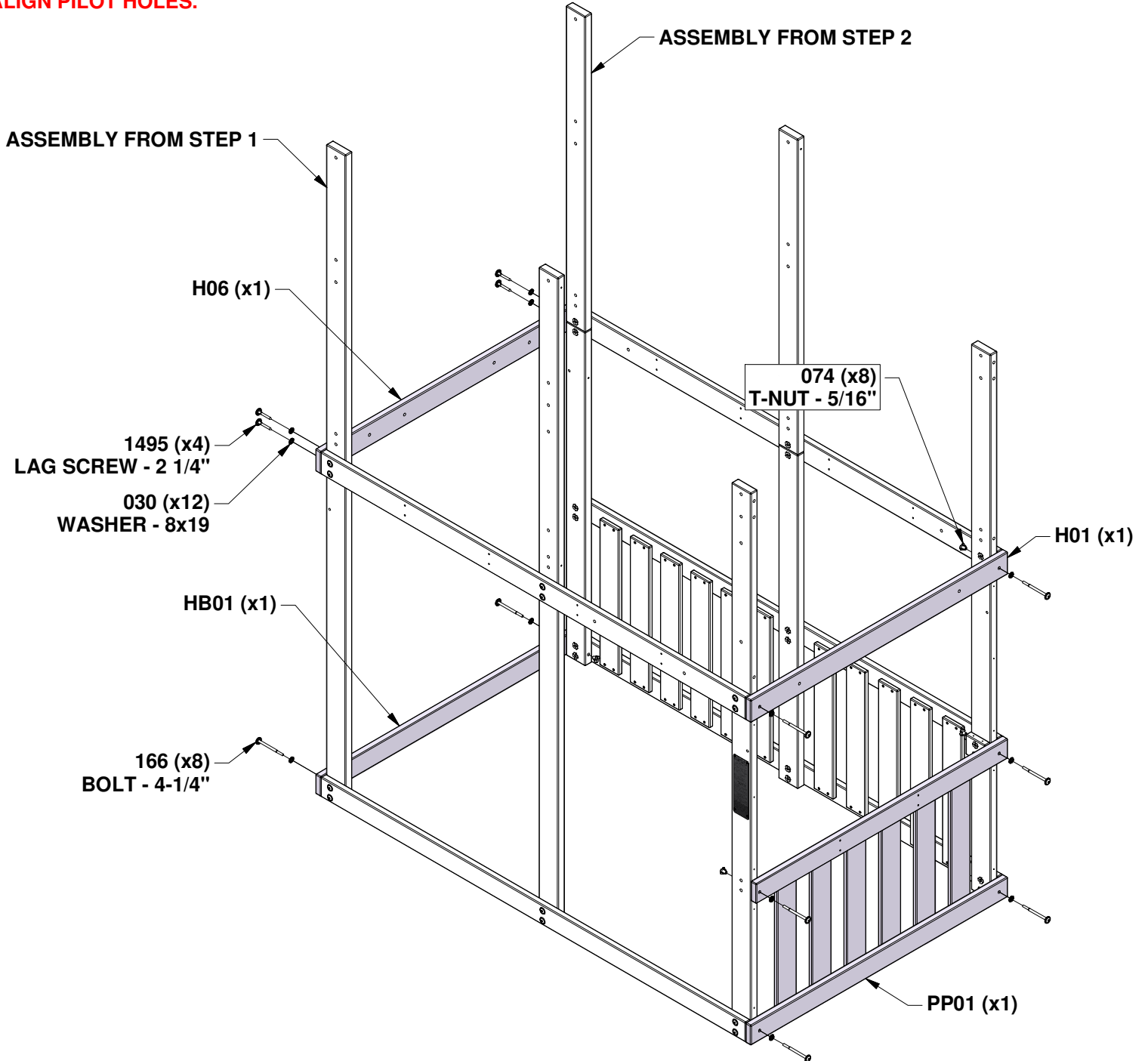

STEP 4 - FORT ASSEMBLY



E11 ANGLE BRACE - W4L22140
 (x6) 1 1/8"x3 3/8"x14 5/8" (30x86x373)

QTY	PART NUMBER	DESCRIPTION
6	H100012	BOLT WH 5/16x2
6	H100030	WASHER LOCK EXT 8x19
6	H100074	T-NUT 5/16
6	H100138	WASHER LOCK EXT 6x15
4	H100139	WASHER LOCK EXT 8x15
4	H100140	NUT BARREL WH 1/4x7/8
4	H100143	BOLT WH 1/4x1-1/2
2	H100146	LAG SCREW WH 1/4x2

**INSTALL T-NUTS IN WOOD FIRST.
 ALIGN PILOT HOLES.**

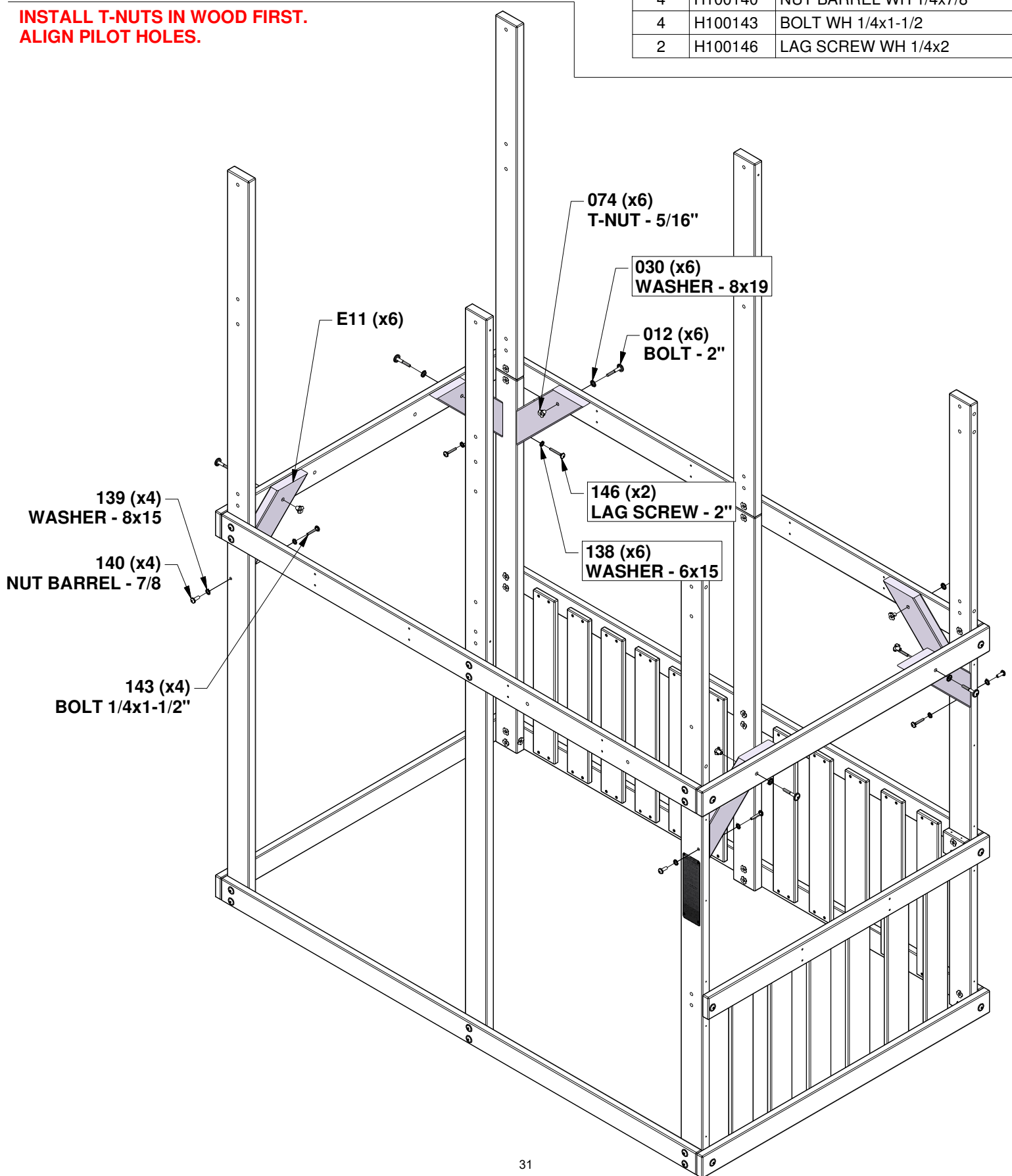

STEP 5 - FORT ASSEMBLY

QTY	PART NUMBER	DESCRIPTION
16	H100111	SCREW PFH 8x2

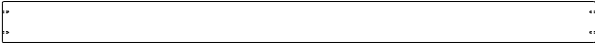

OB05 FLOOR JOIST - W4L22149
(x4) 1 1/8"x3"x43 1/4" (30x76x1099)

ALIGN PILOT HOLES

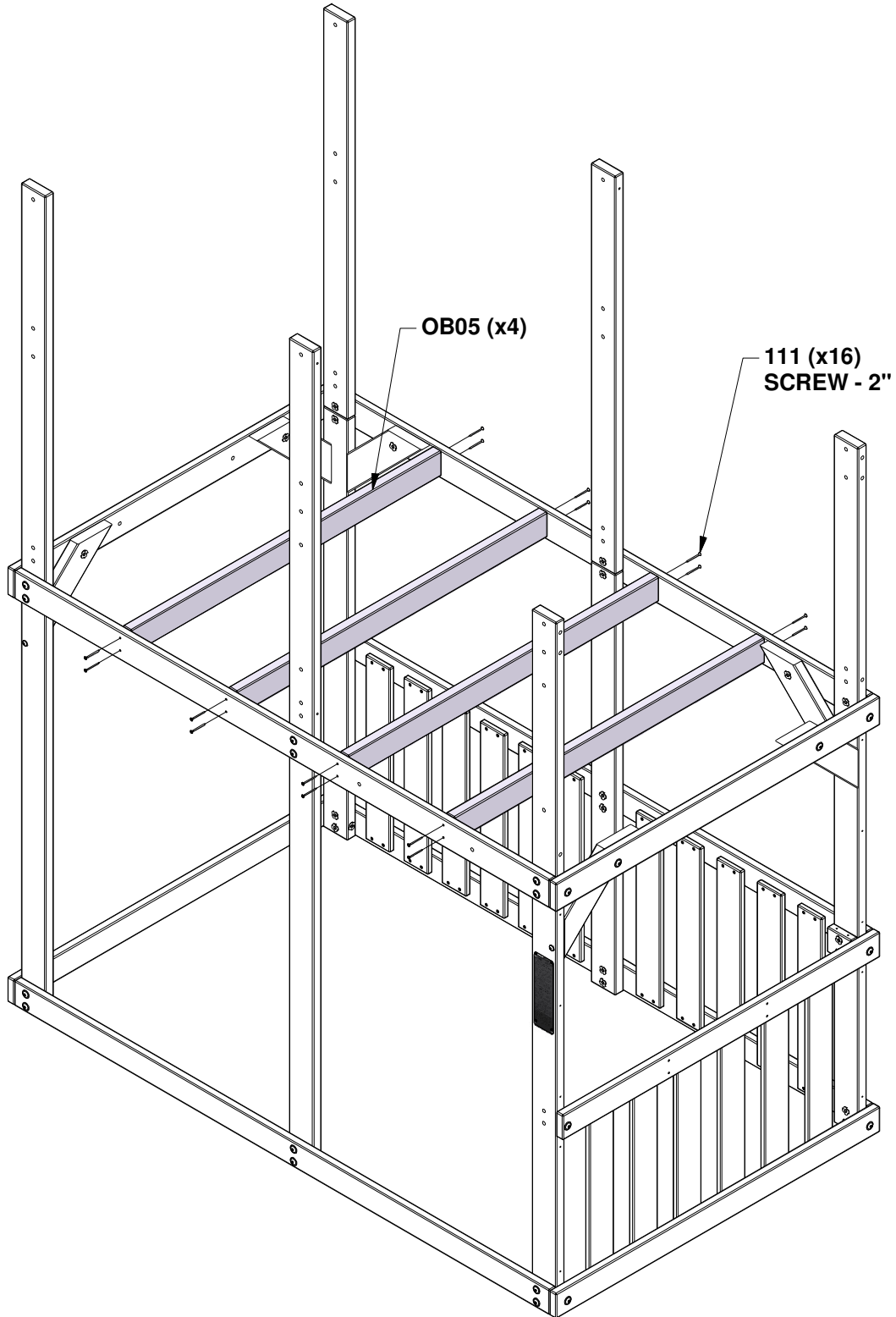

STEP 6 - FORT ASSEMBLY

QTY	PART NUMBER	DESCRIPTION
84	H100086	SCREW PFH 8x1-1/2

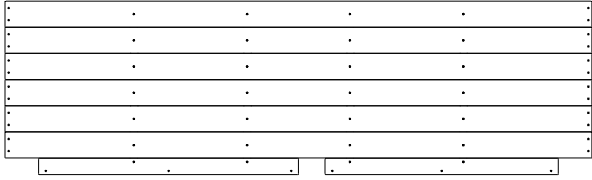

FP01 FLOOR PANEL - W2A04996
 (x1) 1 9/16"x22 11/16"x76 7/16" (40x573x1942)

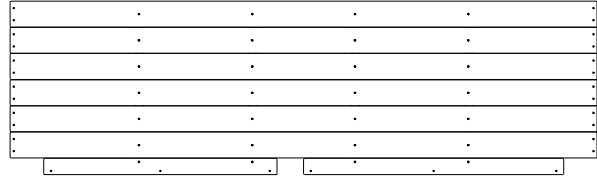

FP02 FLOOR PANEL - W2A04997
 (x1) 1 9/16"x22 11/16"x76 7/16" (40x573x1942)

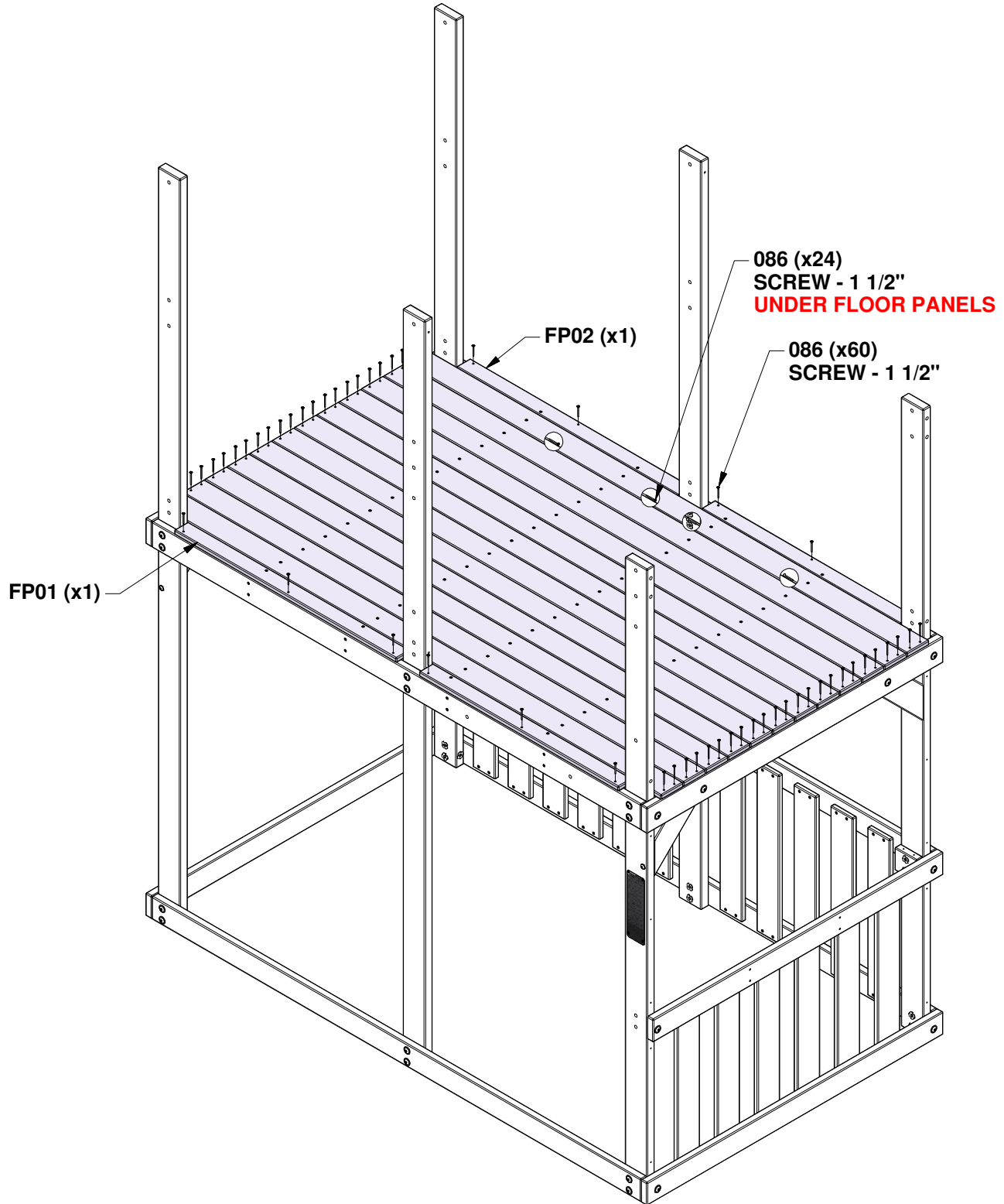

STEP 7 - FORT ASSEMBLY

QTY	PART NUMBER	DESCRIPTION
2	H100011	BOLT WH 5/16x1 3/4
2	H100030	WASHER LOCK EXT 8x19
2	H100074	T-NUT 5/16

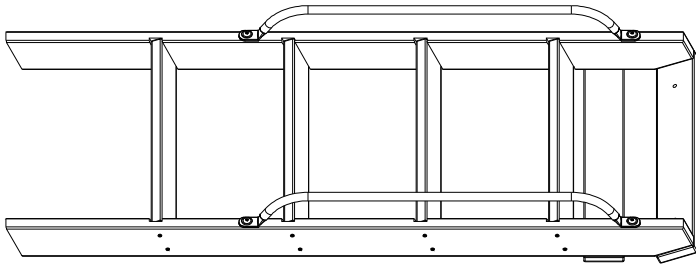

LD01 LADDER
(x1)

INSTALL T-NUTS IN WOOD FIRST

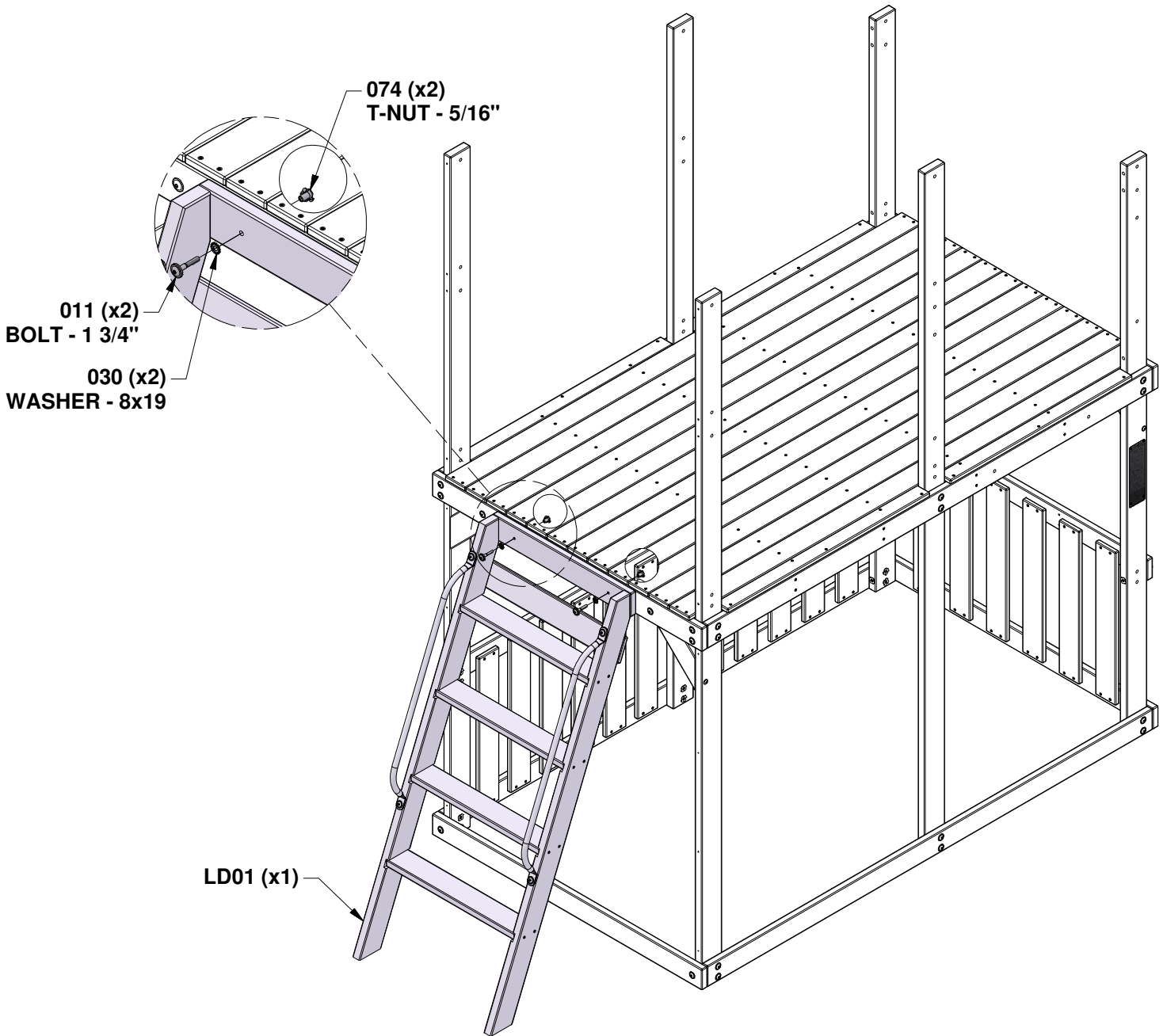

STEP 8 - FORT ASSEMBLY

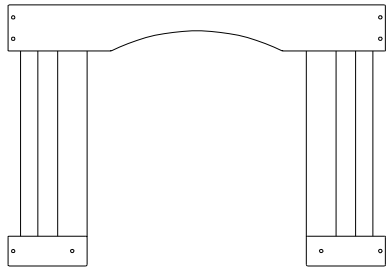

WP01 WALL PANEL - W2A04299
 (x1) 1 7/16"x29 13/16"x43 1/2" (36x758x1099)

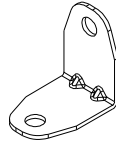

A4M01046 L BRACKET 2.5x38x55x55
 (x2)

QTY	PART NUMBER	DESCRIPTION
2	H100005	NUT BARREL WH 5/16x7/8
2	H100008	BOLT WH 5/16x1
6	H100020	BOLT WH 5/16x4
6	H100030	WASHER LOCK EXT 8x19
2	H100031	WASHER LOCK EXT 12x19
8	H100074	T-NUT 5/16
2	H100115	BOLT WH 5/16x1/2

INSTALL T-NUTS IN WOOD FIRST

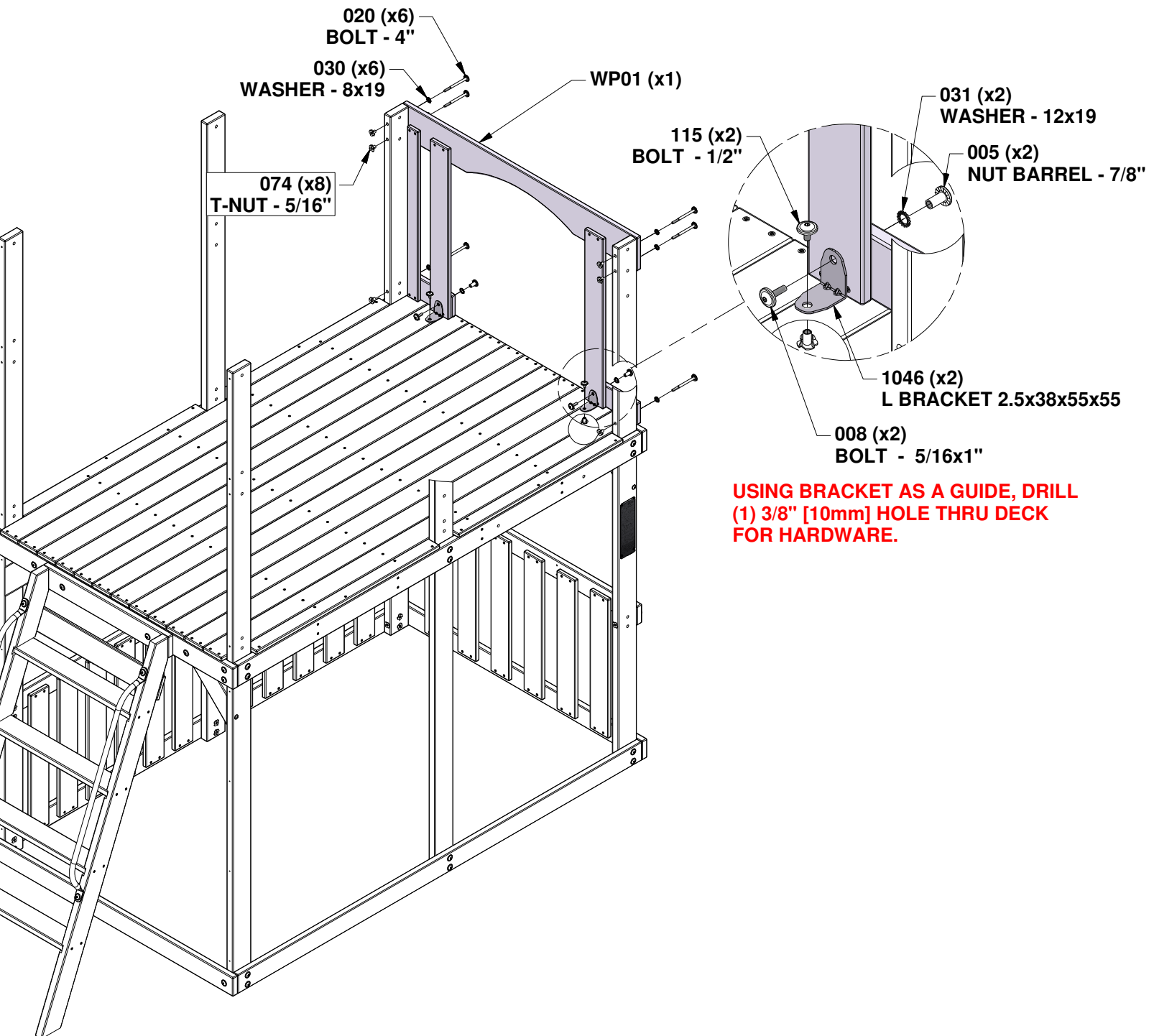

STEP 9 - FORT ASSEMBLY

QTY	PART NUMBER	DESCRIPTION
2	H100005	NUT BARREL WH 5/16x7/8
2	H100008	BOLT WH 5/16x1
6	H100011	BOLT WH 5/16x1 3/4
2	H100012	BOLT WH 5/16x2
2	H100015	BOLT WH 5/16x2 3/4
10	H100030	WASHER LOCK EXT 8x19
2	H100031	WASHER LOCK EXT 12x19
12	H100074	T-NUT 5/16
2	H100115	BOLT WH 5/16x1/2

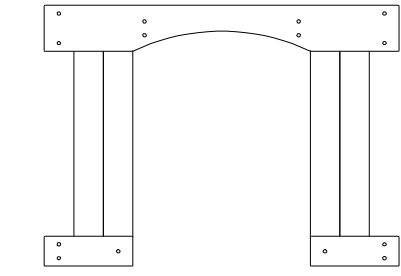

WP13 WALL PANEL - W2A04999
(x1) 1 9/16"x29 13/16"x40 11/16" (40x758x1034)



NJ01 WALL RAIL - W4L22150
(x1) 3/4"x5 1/4"x37 1/4" (20x134x946)



A4M01046 L BRACKET 2.5x38x55x55
(x2)

INSTALL T-NUTS IN WOOD FIRST

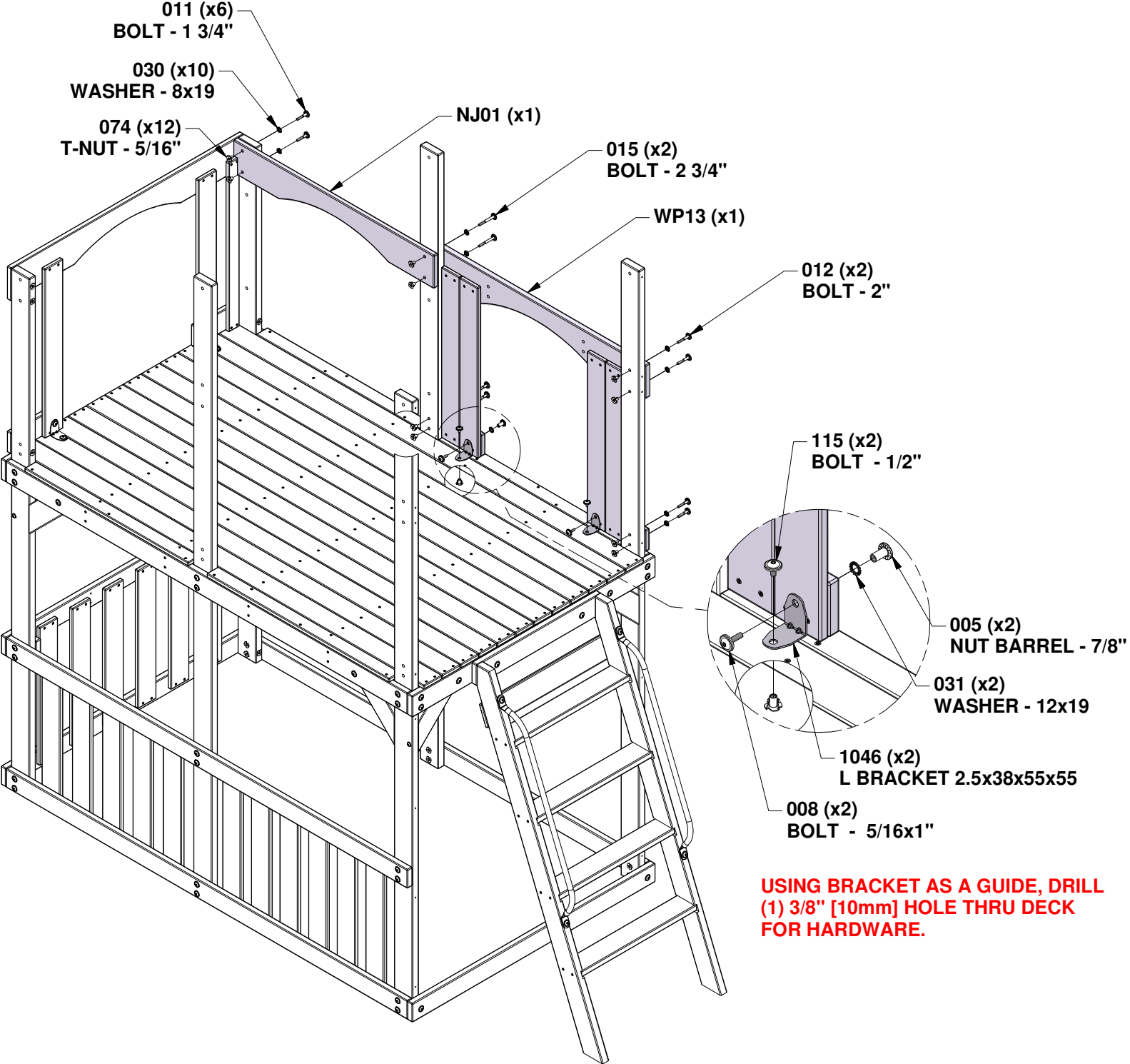

USING BRACKET AS A GUIDE, DRILL (1) 3/8" [10mm] HOLE THRU DECK FOR HARDWARE.

STEP 10 - FORT ASSEMBLY

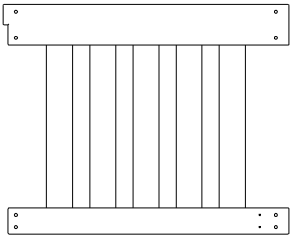

WP03 WALL PANEL - W2A04298
 (x1) 1 7/16"x29 13/16"x37 1/4" (36x758x946)

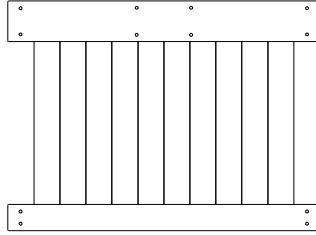

WP12 WALL PANEL - W2A04994
 (x1) 1 13/16"x29 13/16"x40 11/16" (46x758x1034)

QTY	PART NUMBER	DESCRIPTION
6	H100011	BOLT WH 5/16x1 3/4
2	H100013	BOLT WH 5/16x2 1/4
2	H100015	BOLT WH 5/16x2 3/4
2	H100016	BOLT WH 5/16x3
12	H100030	WASHER LOCK EXT 8x19
12	H100074	T-NUT 5/16

INSTALL T-NUTS IN WOOD FIRST

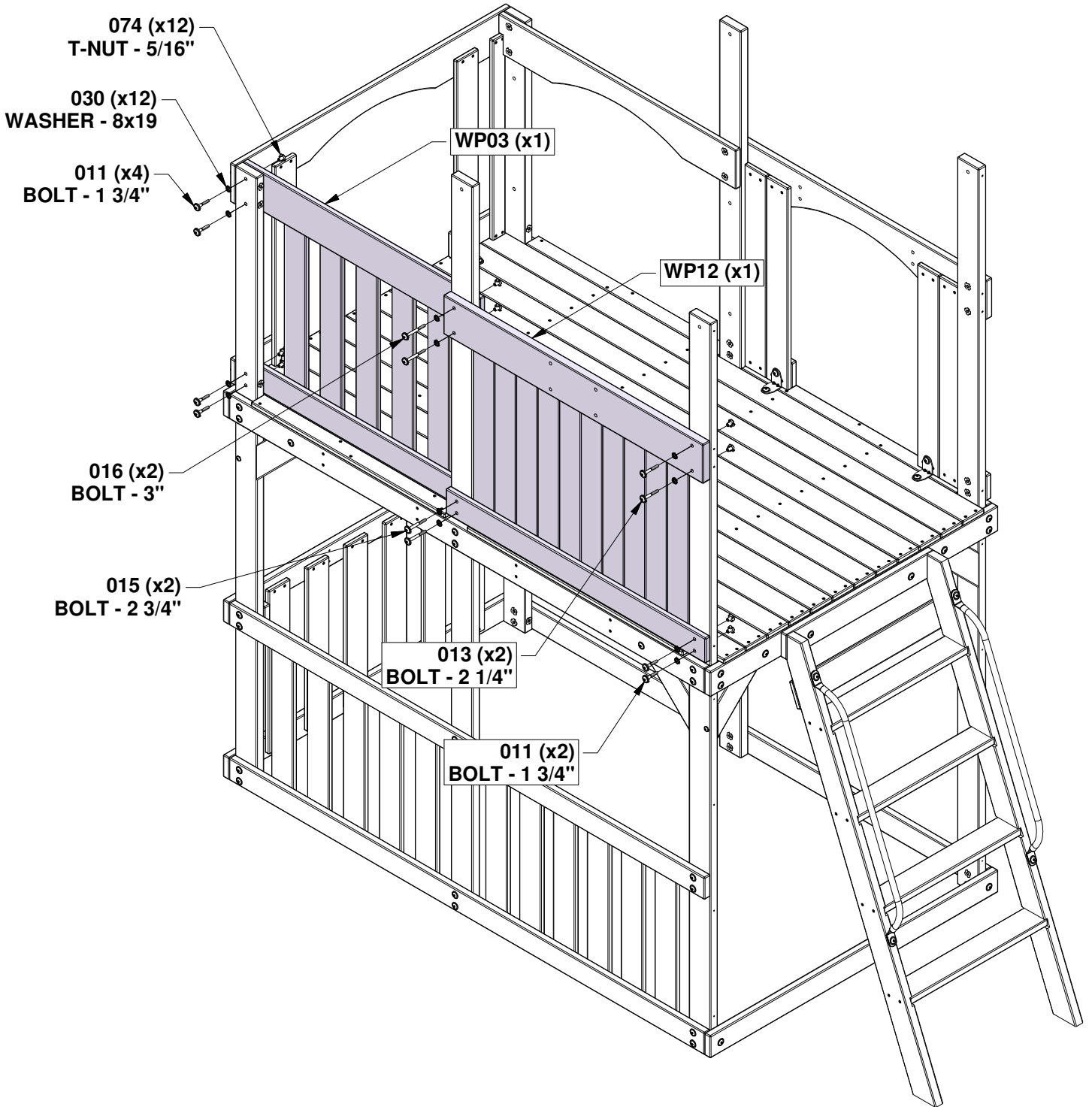

STEP 11 - FORT ASSEMBLY

QTY	PART NUMBER	DESCRIPTION
2	H100011	BOLT WH 5/16x1 3/4
2	H100030	WASHER LOCK EXT 8x19
2	H100074	T-NUT 5/16
20	H100087	SCREW PFH 8x1-1/4

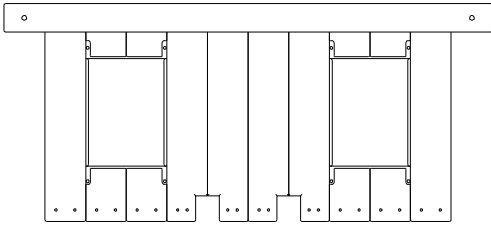

WP05 WALL PANEL - W2A04995
 (x1) 2 1/16"x18 1/8"x40 11/16" (52x460x1034)

INSTALL T-NUTS IN WOOD FIRST

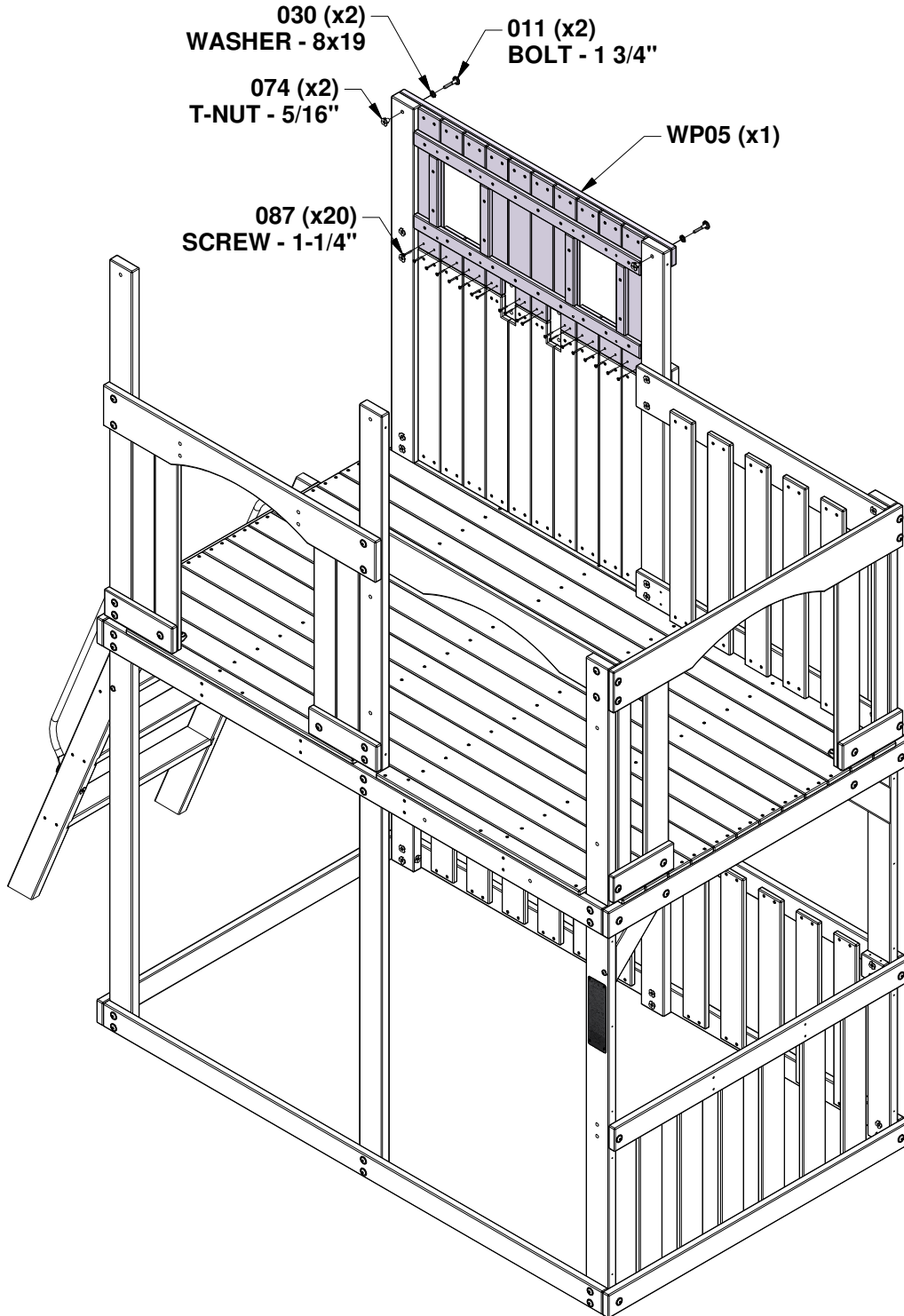

STEP 12 - FORT ASSEMBLY

QTY	PART NUMBER	DESCRIPTION
2	H100011	BOLT WH 5/16x1 3/4
2	H100030	WASHER LOCK EXT 8x19
2	H100074	T-NUT 5/16
18	H100087	SCREW PFH 8x1-1/4

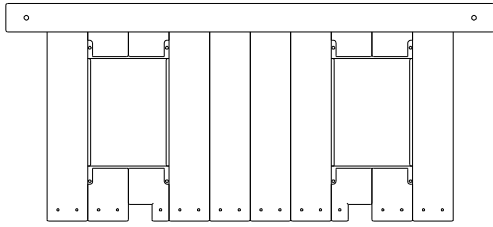

WP02 WALL PANEL - W2A04998
 (x1) 2 1/16"x18 1/8"x40 11/16" (52x460x1034)

INSTALL T-NUTS IN WOOD FIRST

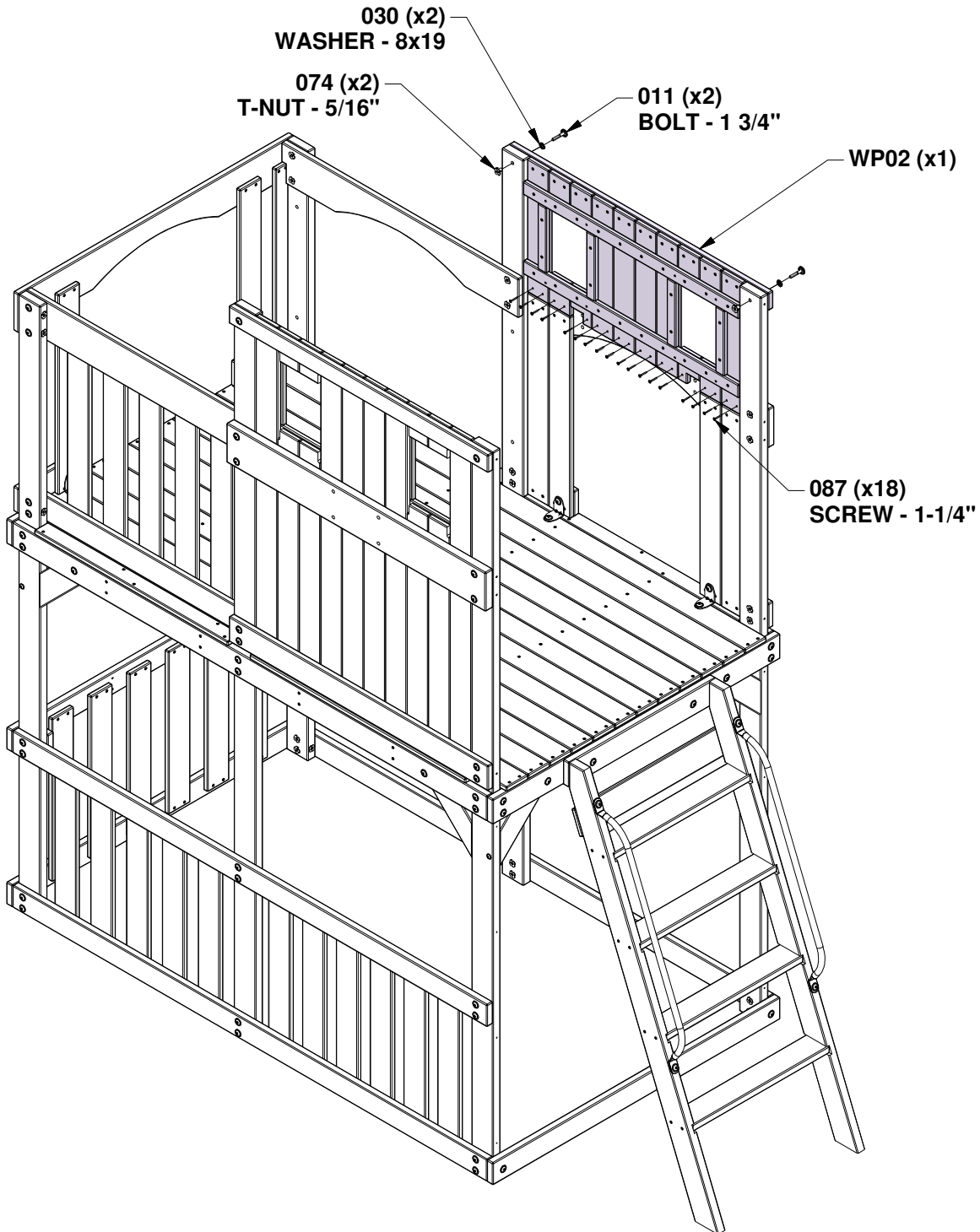

STEP 13 - FORT ASSEMBLY

QTY	PART NUMBER	DESCRIPTION
6	H100027	LAG SCREW WH 5/16x2
6	H100030	WASHER LOCK EXT 8x19

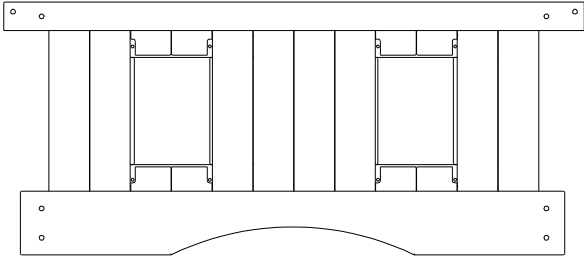

WP04 WALL PANEL - W2A05000
(x1) 2 1/16"x21"x48 7/16" (52x534x1230)

ALIGN PILOT HOLES.

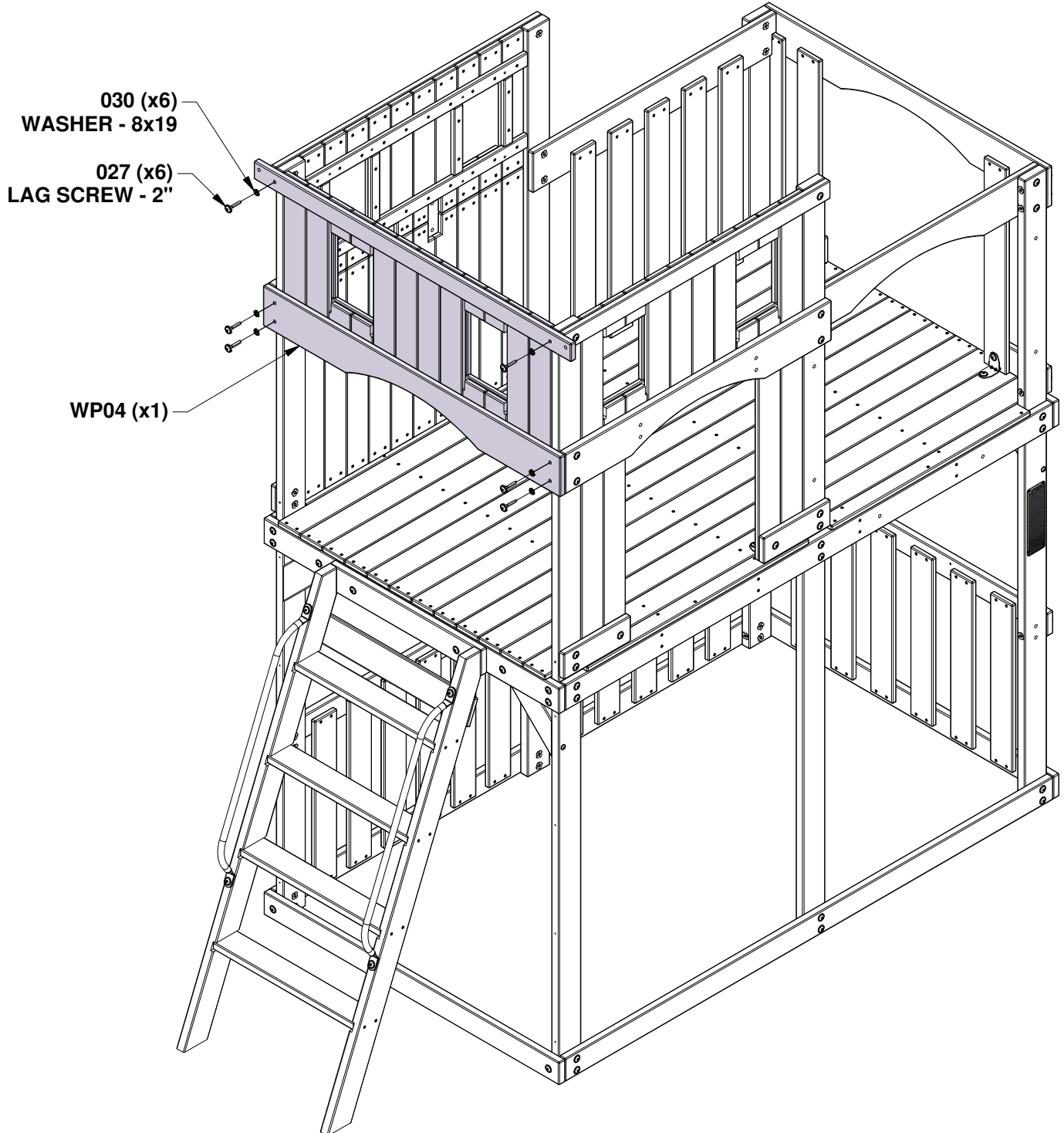

STEP 14 - FORT ASSEMBLY

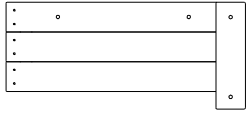

WP08 WALL PANEL - W2A05001
(x1) 2 1/16"x12 3/16"x27 7/16" (52x310x697)

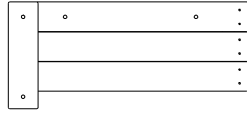

WP09 WALL PANEL - W2A05002
(x1) 2 1/16"x12 3/16"x27 7/16" (52x310x697)



A4M01046 L BRACKET 2.5x38x55x55
(x2)

QTY	PART NUMBER	DESCRIPTION
2	H100005	NUT BARREL WH 5/16x7/8
2	H100008	BOLT WH 5/16x1
2	H100027	LAG SCREW WH 5/16x2
2	H100030	WASHER LOCK EXT 8x19
2	H100031	WASHER LOCK EXT 12x19
2	H100074	T-NUT 5/16
12	H100087	SCREW PFH 8x1-1/4
2	H100115	BOLT WH 5/16x1/2

ALIGN PILOT HOLES.

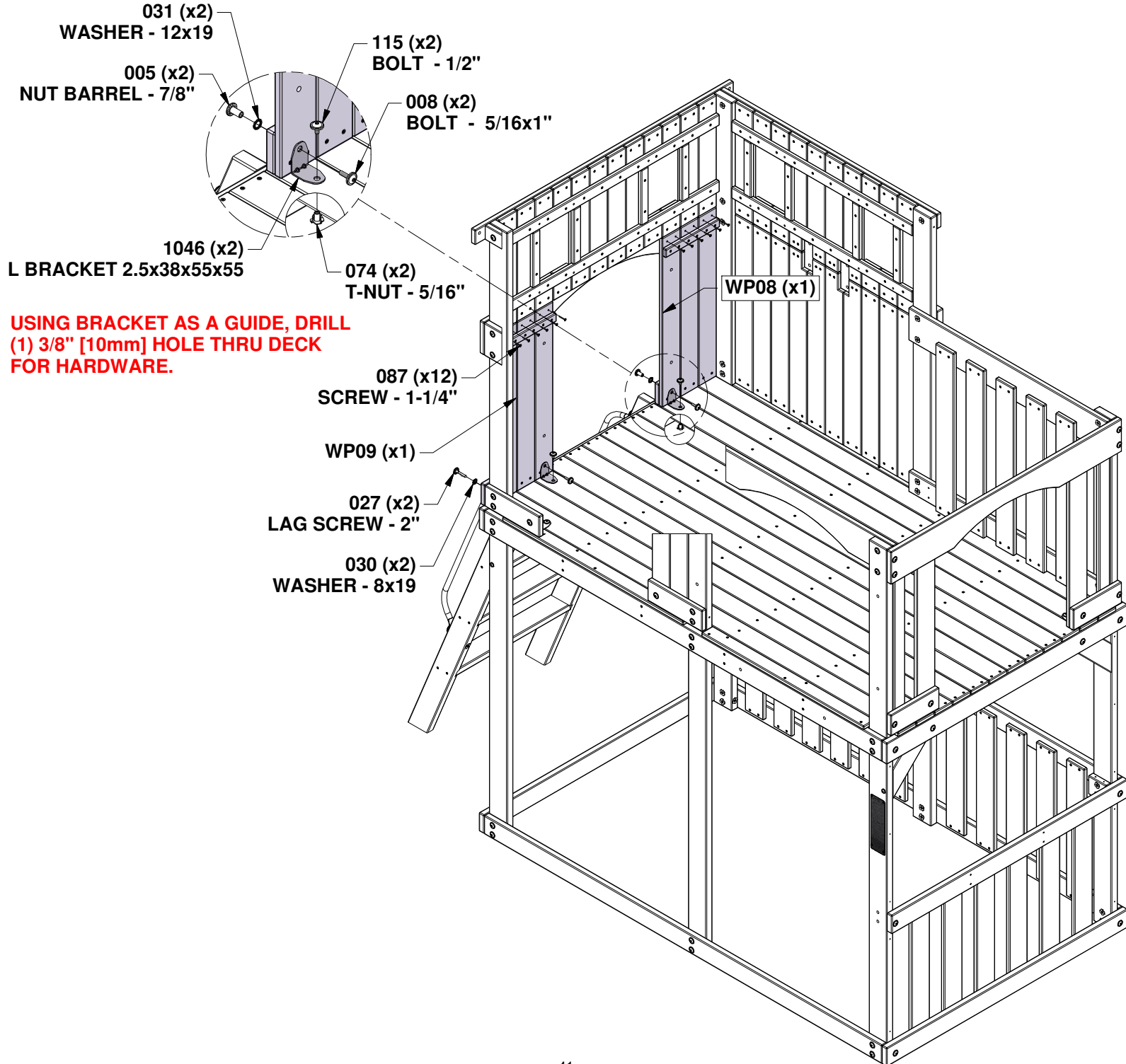

STEP 15 - FORT ASSEMBLY

QTY	PART NUMBER	DESCRIPTION
2	H100027	LAG SCREW WH 5/16x2
2	H100030	WASHER LOCK EXT 8x19



NG07 WALL RAIL - W4L22151
(x1) 3/4"x3 3/8"x48 3/8" (20x86x1230)

ALIGN PILOT HOLES.

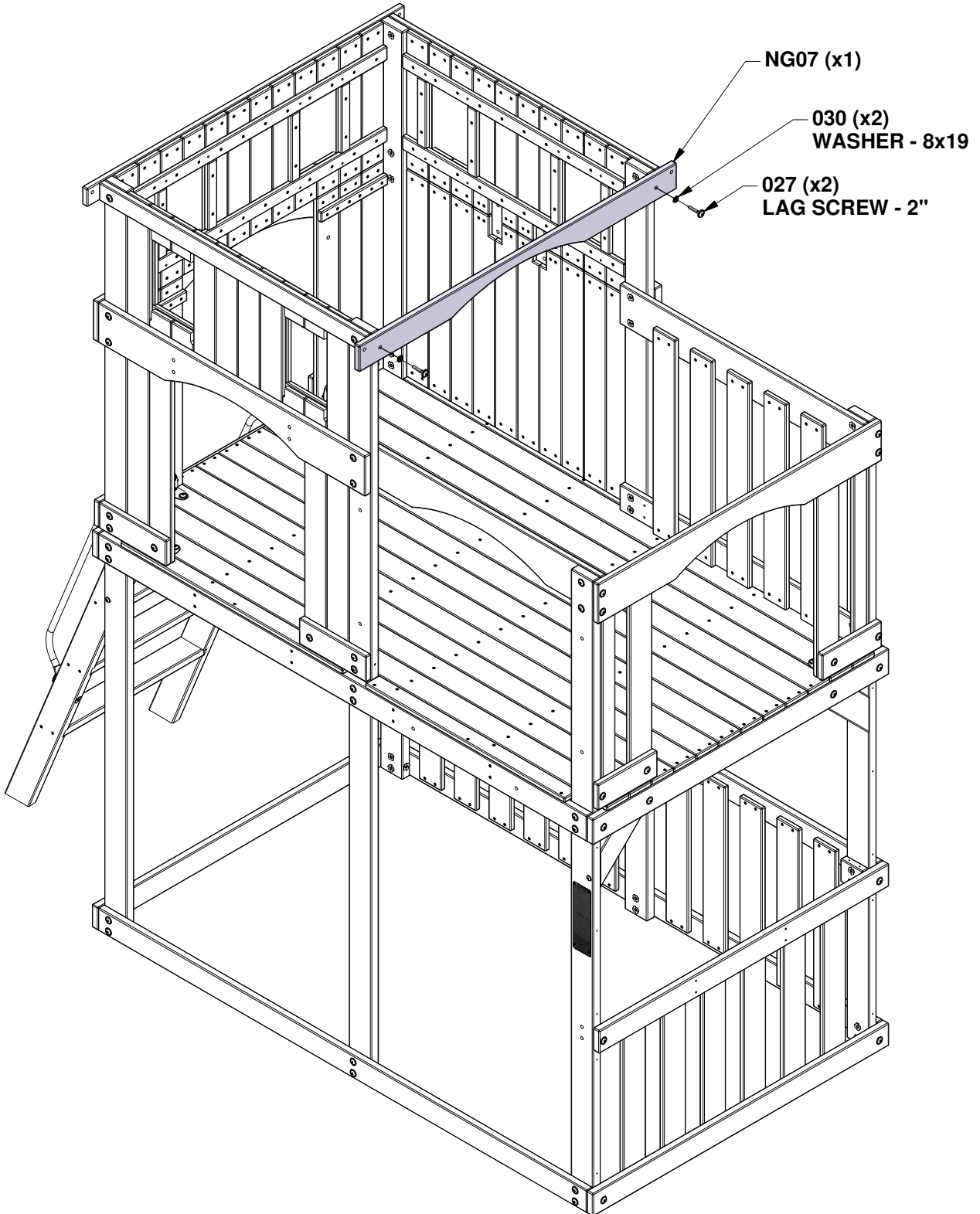

STEP 16 - FORT ASSEMBLY

QTY	PART NUMBER	DESCRIPTION
2	H100005	NUT BARREL WH 5/16x7/8
2	H100008	BOLT WH 5/16x1
1	H100027	LAG SCREW WH 5/16x2
1	H100030	WASHER LOCK EXT 8x19
2	H100031	WASHER LOCK EXT 12x19
2	H100074	T-NUT 5/16
12	H100087	SCREW PFH 8x1-1/4
2	H100111	SCREW PFH 8x2
2	H100115	BOLT WH 5/16x1/2

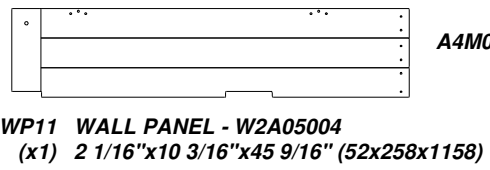
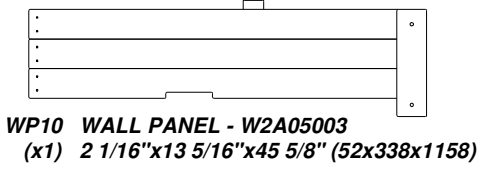

ALIGN PILOT HOLES.

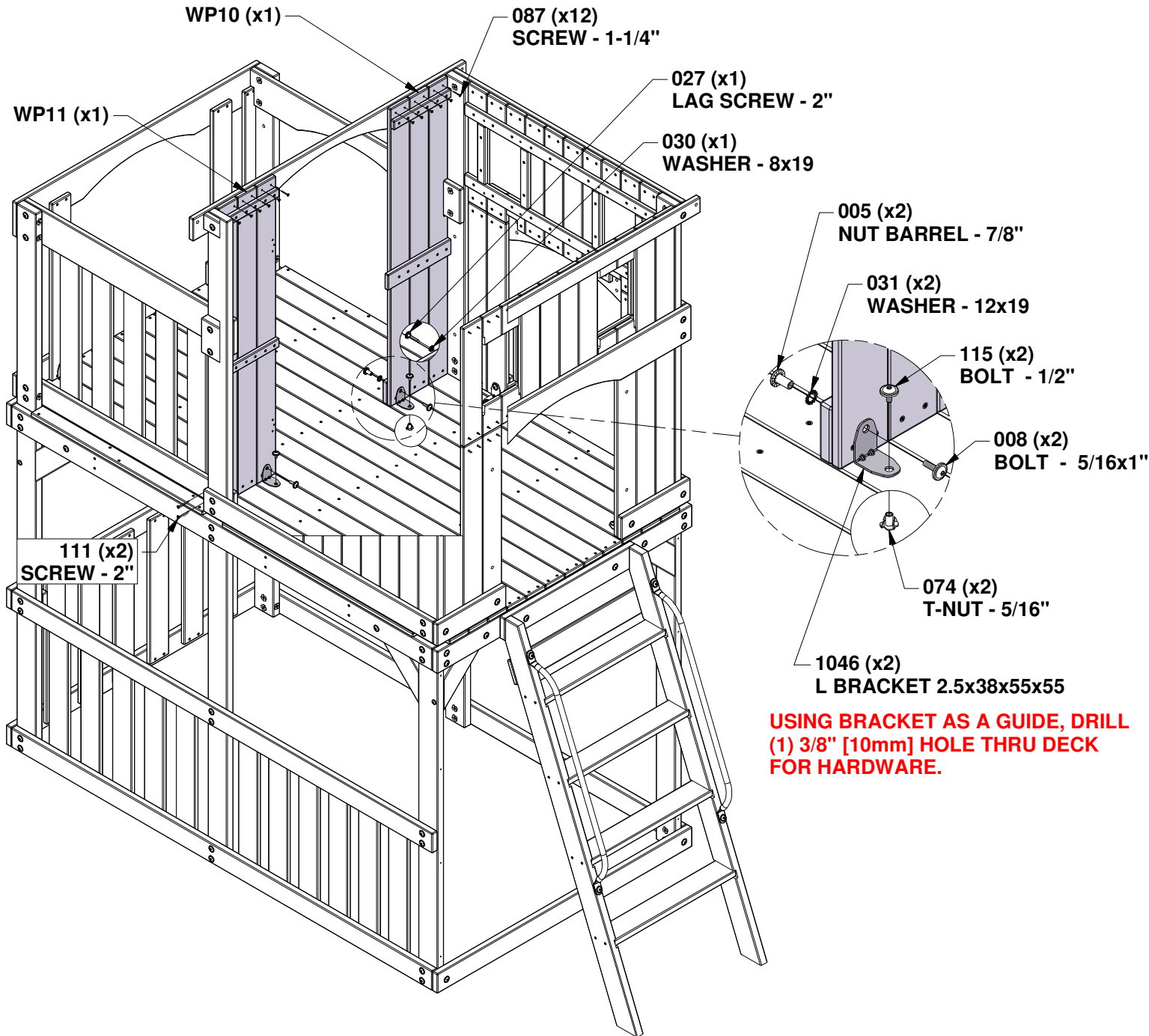

USING BRACKET AS A GUIDE, DRILL (1) 3/8" [10mm] HOLE THRU DECK FOR HARDWARE.

STEP 17 - FORT ASSEMBLY



H12 ROOF TRUSS - W4L22129
 (x4) 1"x3 3/8"x40" (24x86x1016)

QTY	PART NUMBER	DESCRIPTION
4	H100010	BOLT WH 5/16x1 1/2
4	H100030	WASHER LOCK EXT 8x19
4	H100074	T-NUT 5/16

INSTALL T-NUTS IN WOOD FIRST

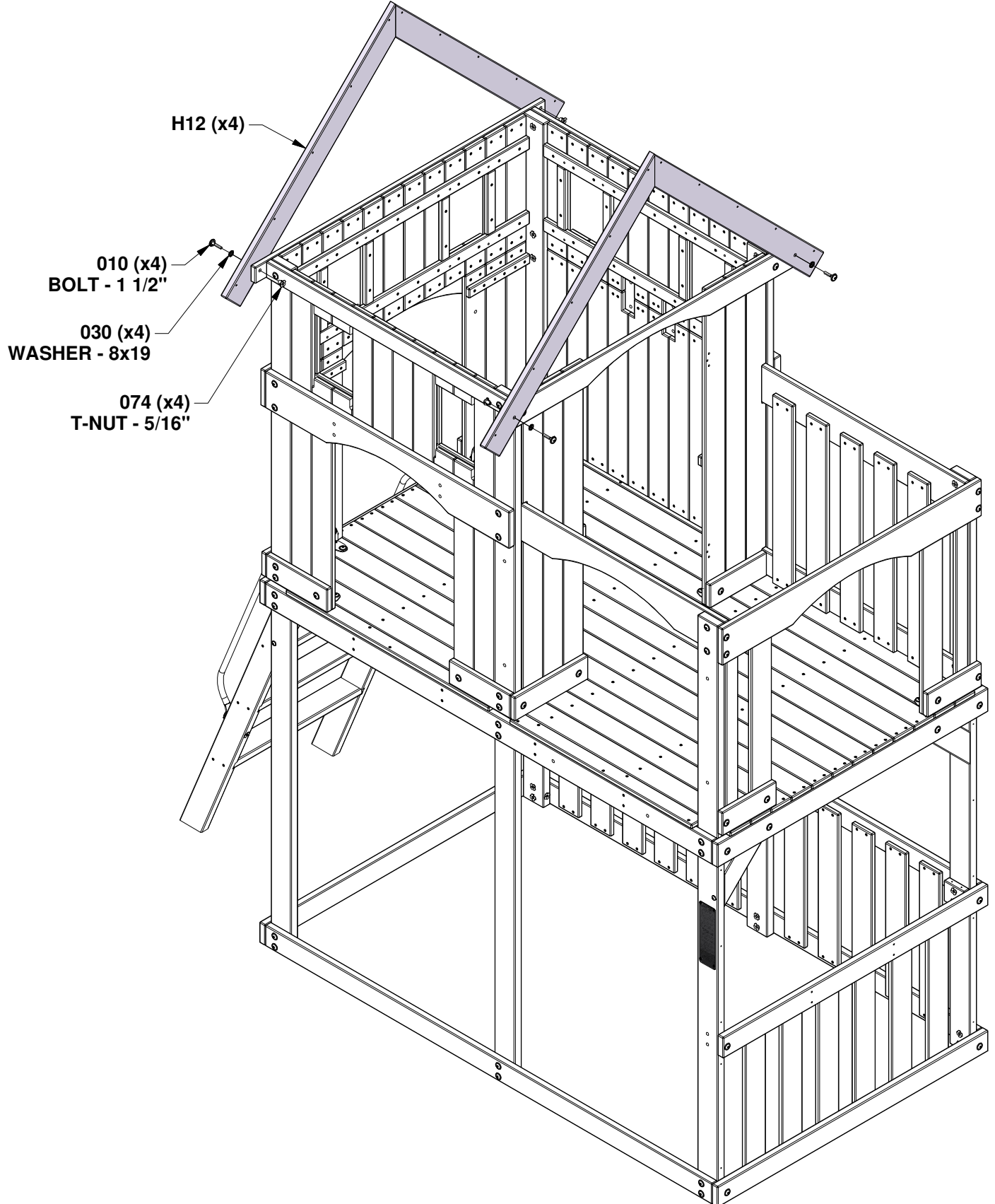

STEP 18 - FORT ASSEMBLY

QTY	PART NUMBER	DESCRIPTION
16	H100087	SCREW PFH 8x1-1/4

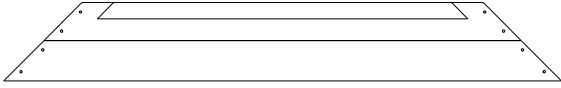

GP01 GABLE PANEL - W2A04296
(x2) 1 7/8"x6 9/16"x46 9/16" (48x166x1182)

CENTER PANELS

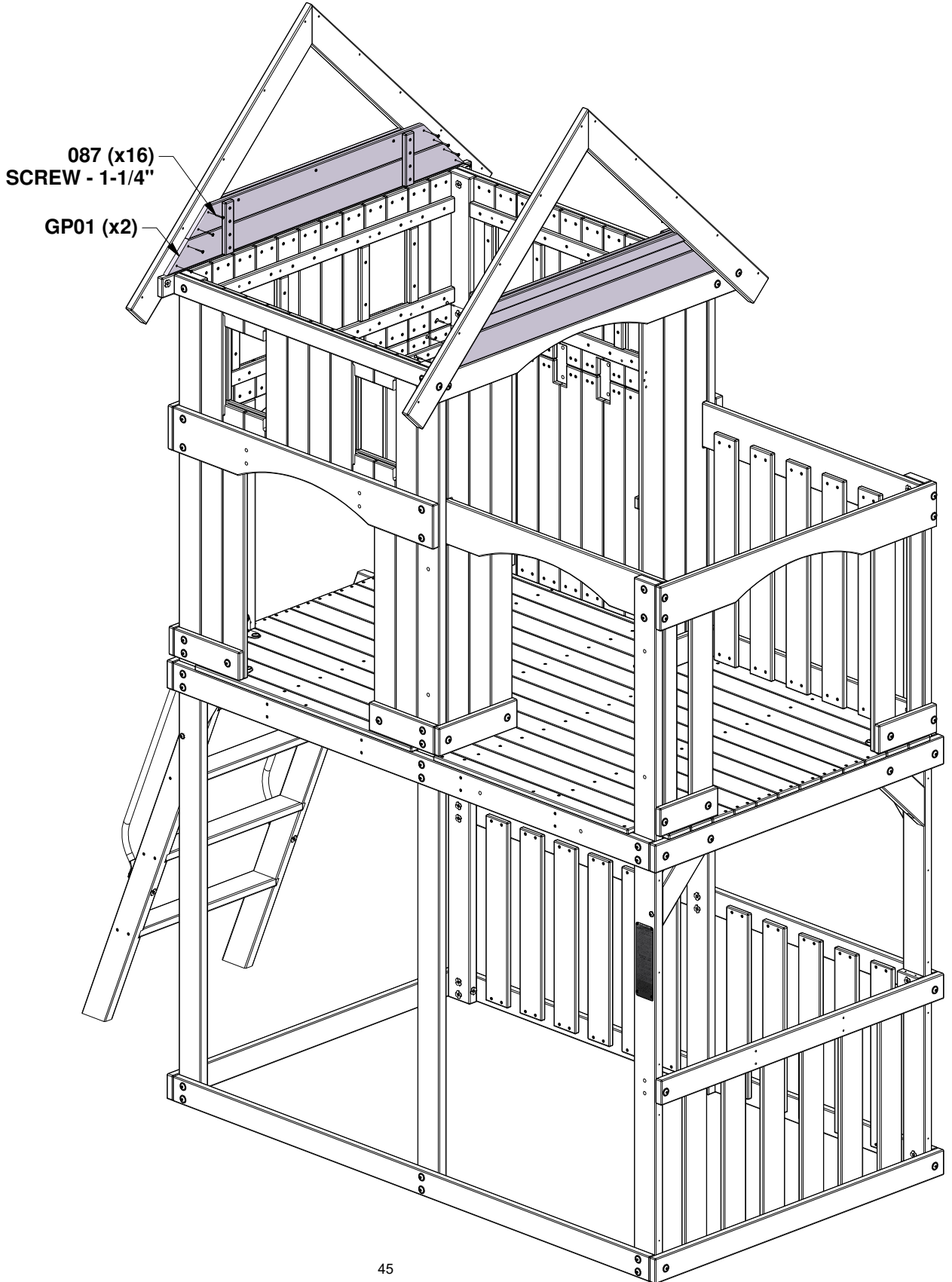

STEP 19 - FORT ASSEMBLY

QTY	PART NUMBER	DESCRIPTION
12	H100070	SCREW PWH 8x3/4

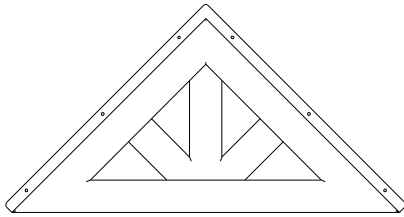

A100331 PLASTIC GABLE
(x2)

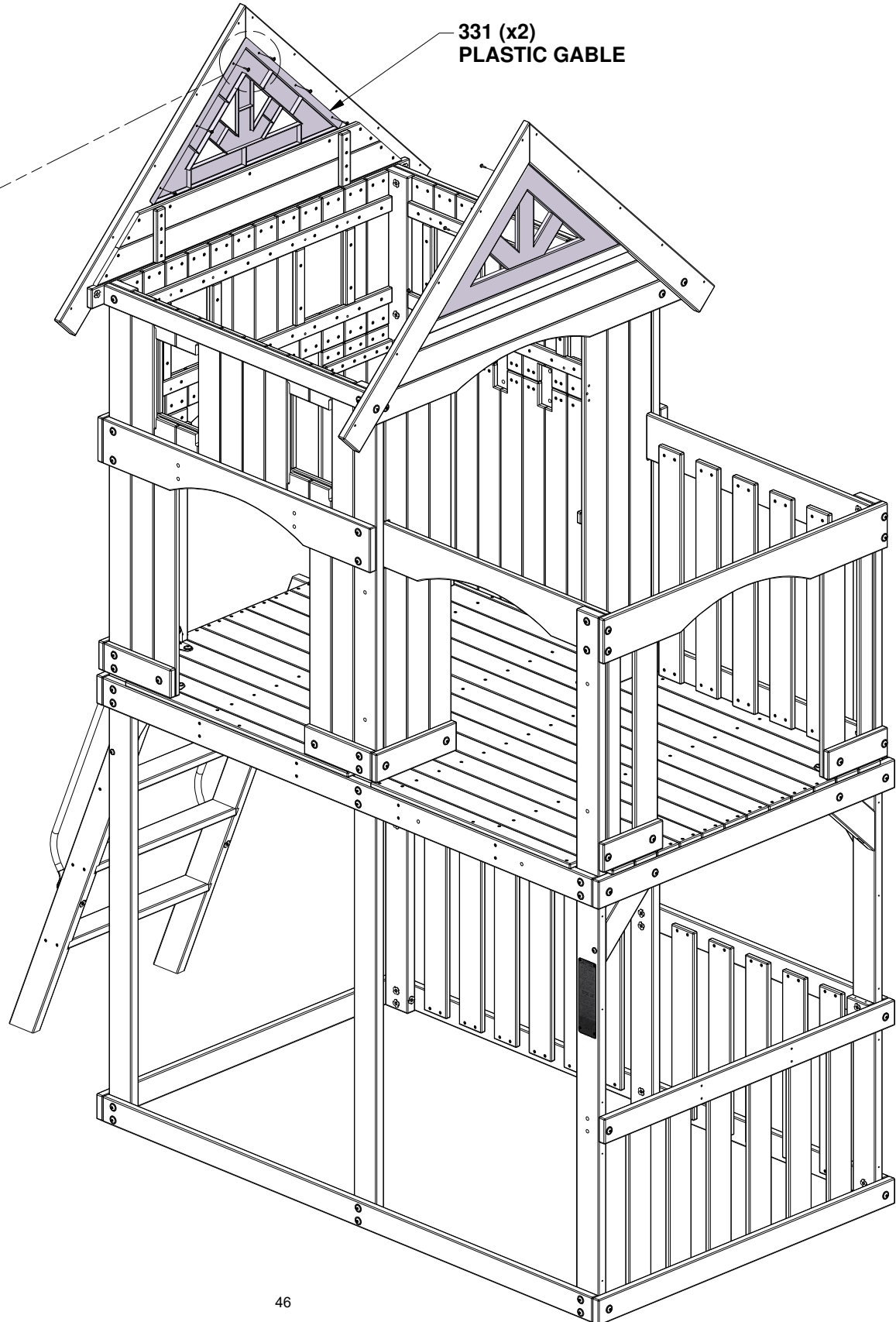

331 (x2)
PLASTIC GABLE

070 (x12)
SCREW - 3/4"

STEP 20 - FORT ASSEMBLY

QTY	PART NUMBER	DESCRIPTION
24	H100181	SCREW PWH 8x1-5/8

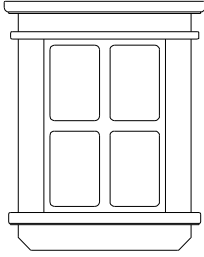

A100320 PLASTIC WINDOW 44x266x329
(x6)

**CENTER WINDOWS
ALIGN PILOT HOLES.**

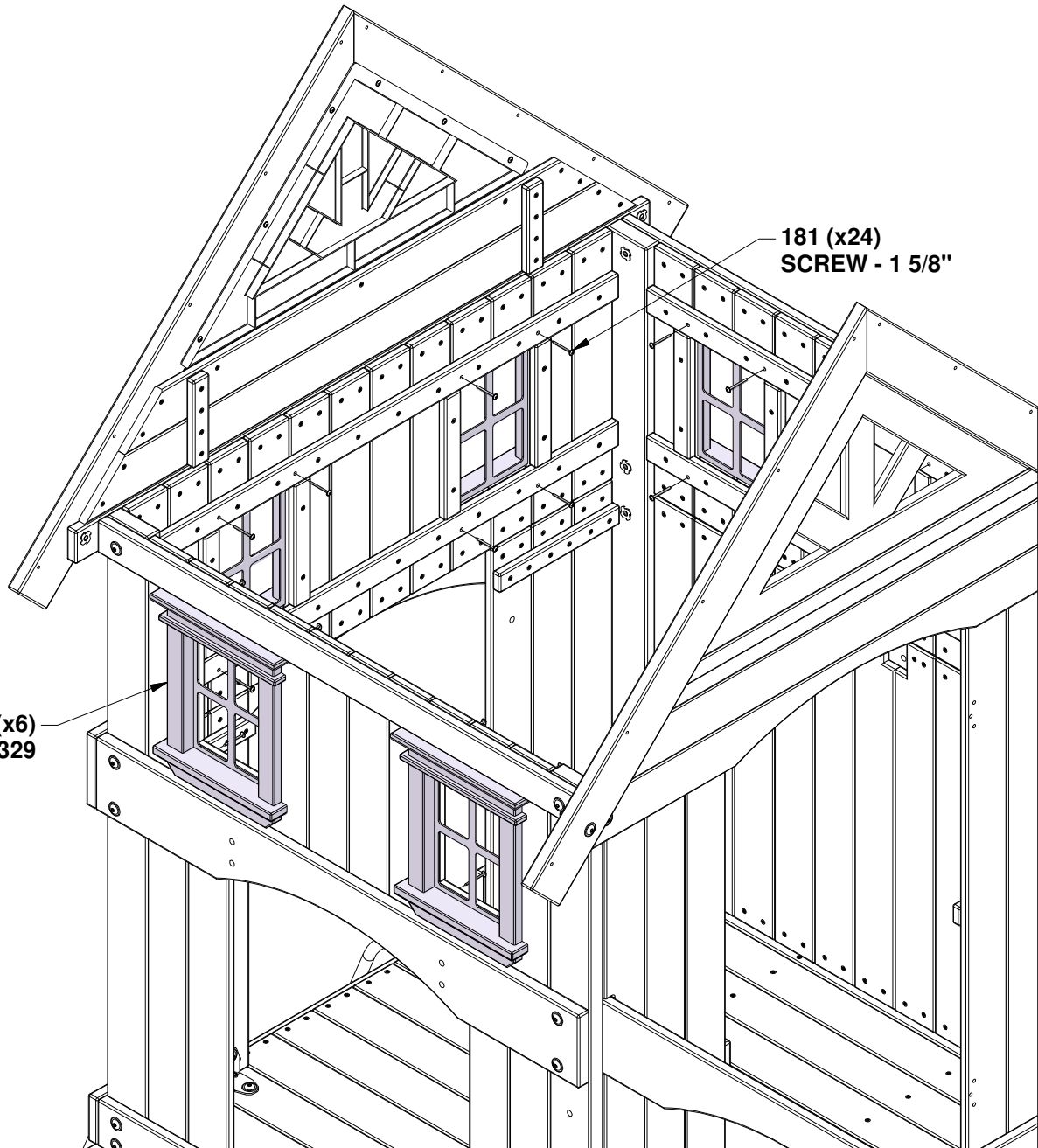

STEP 21 - FORT ASSEMBLY

QTY	PART NUMBER	DESCRIPTION
20	H100089	SCREW PFH 8x1-3/4

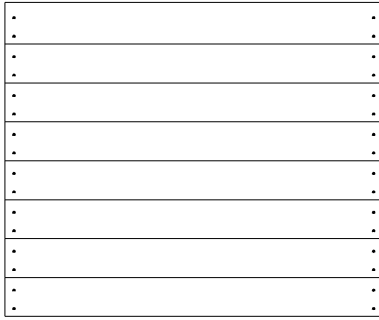

RP01 ROOF PANEL - W2A04295
(x2) 1 5/8"x40 7/8"x49 3/16" (42x1038x1250)

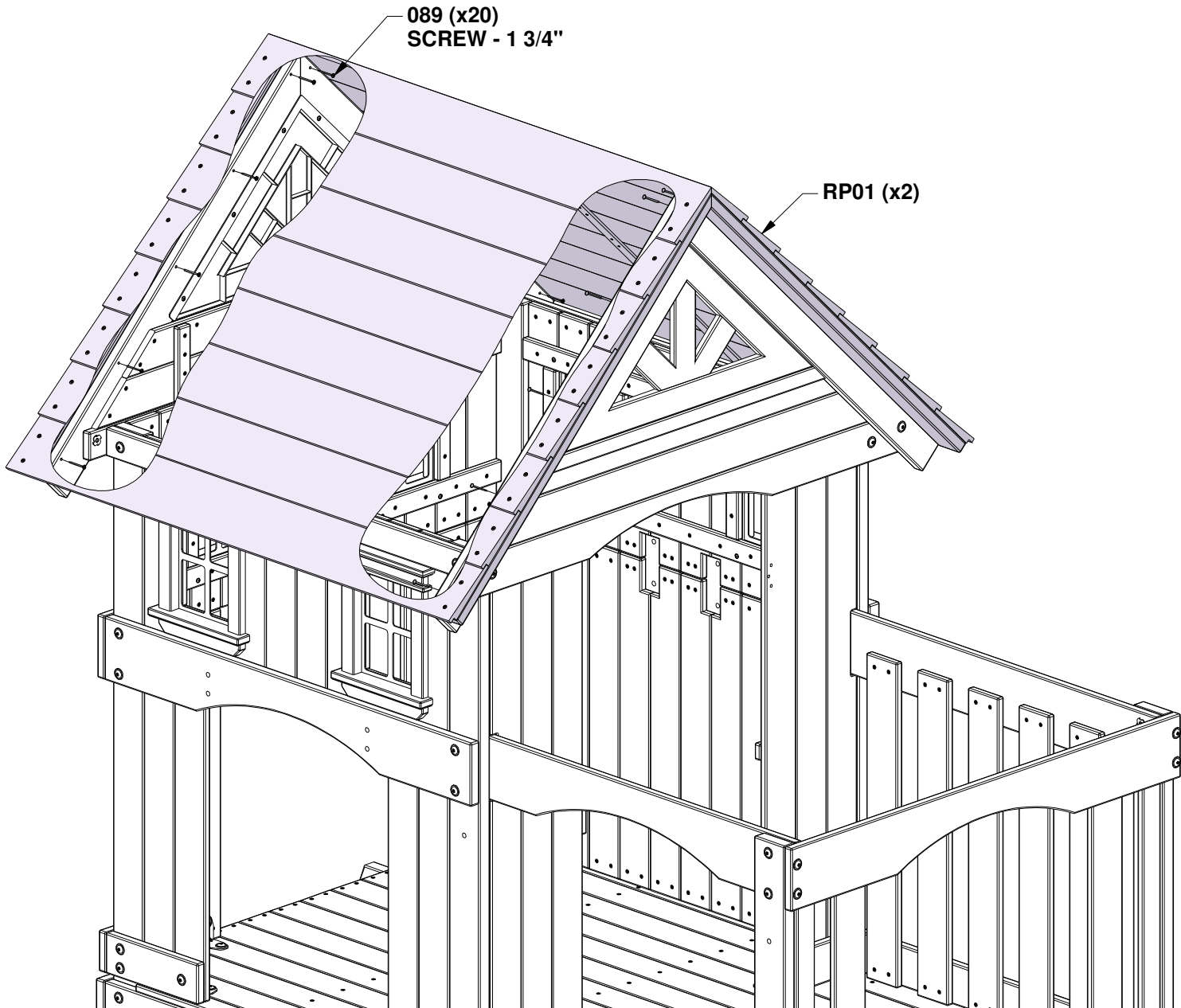

STEP 22 - FORT ASSEMBLY

QTY	PART NUMBER	DESCRIPTION
12	H100804	T-NUT 8/32 BLK
12	H101475	SCREW POH-MS 8/32x5/8" BLK

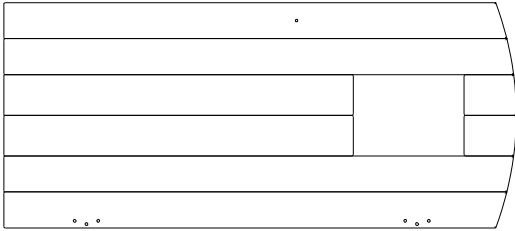

DP01 DOOR PANEL - W2A05005
 (x1) 1 1/4"x18 3/4"x42 11/16" (32x476x1085)

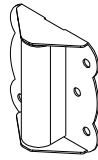

A100327 HINGE (DOOR, SPRING LOADED)
 (x2)

**INSTALL T-NUTS IN WOOD FIRST.
 ALIGN PILOT HOLES.**

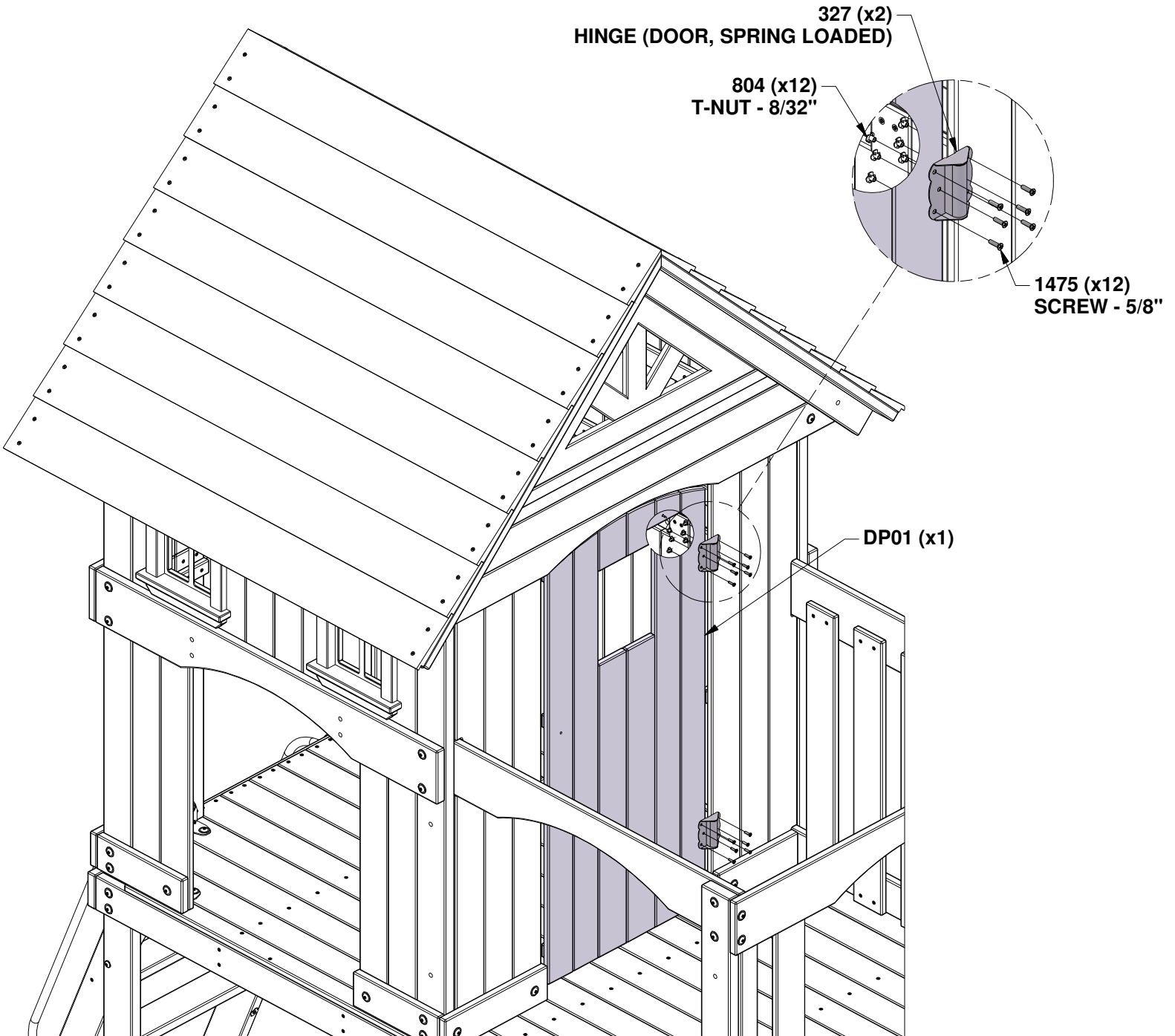

STEP 23 - FORT ASSEMBLY

QTY	PART NUMBER	DESCRIPTION
4	H100070	SCREW PWH 8x3/4
1	H100086	SCREW PFH 8x1-1/2

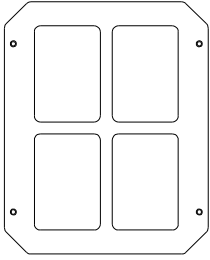

A100014 PLASTIC WINDOW WHITE
(x1)

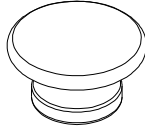

A6P00274 KNOB
(x1)

**CENTER WINDOW ON DOOR.
ALIGN PILOT HOLE FOR KNOB.**

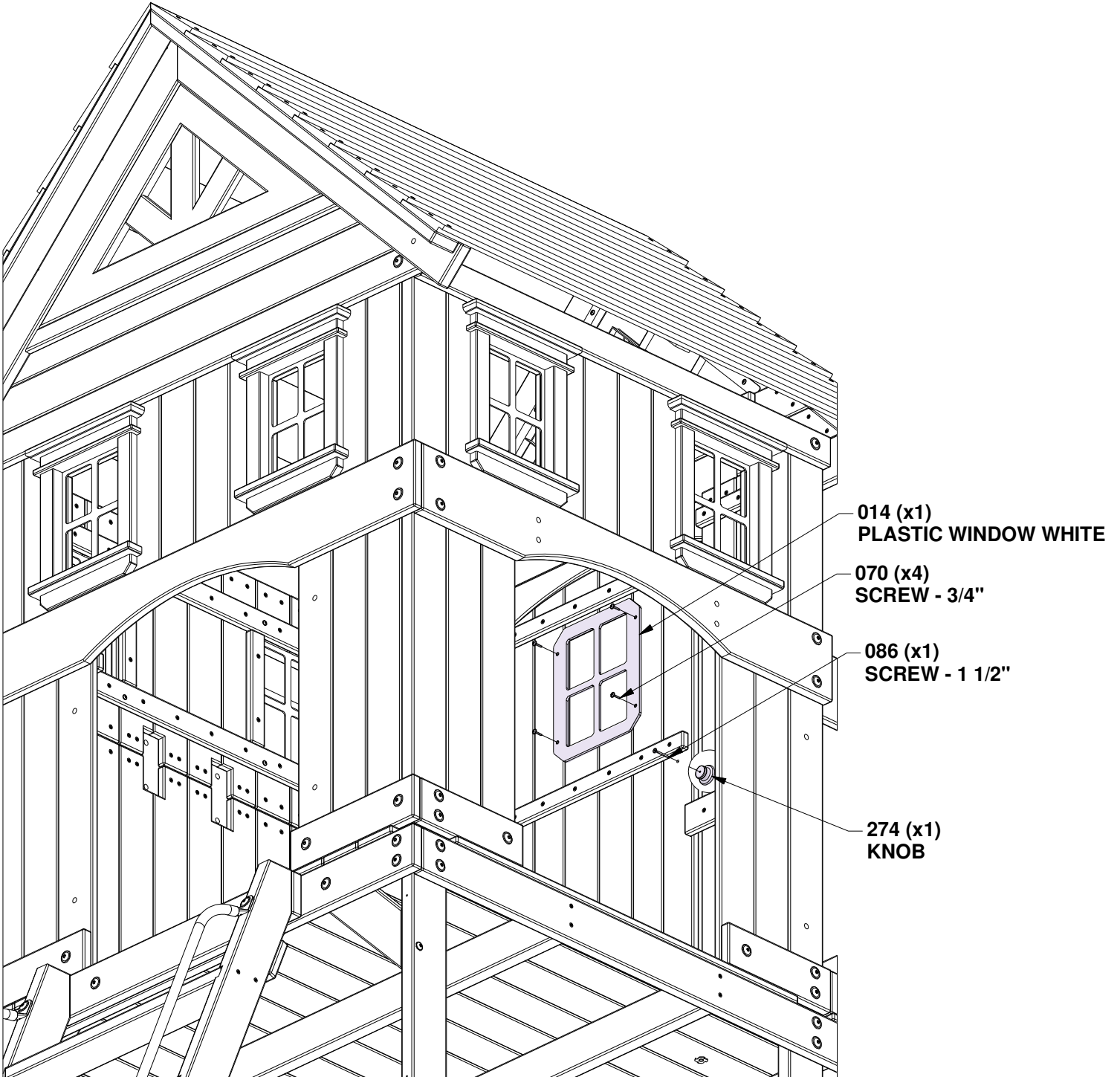

STEP 24 - FORT ASSEMBLY

QTY	PART NUMBER	DESCRIPTION
10	H100089	SCREW PFH 8x1-3/4

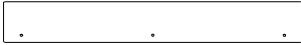

M02 UPRIGHT - W4L22167
(x2) 5/8"x3 3/8"x24 7/8" (16x86x633)



M03 UPRIGHT - W4L22168
(x2) 5/8"x3 3/8"x18" (16x86x457)

ALIGN PILOT HOLES

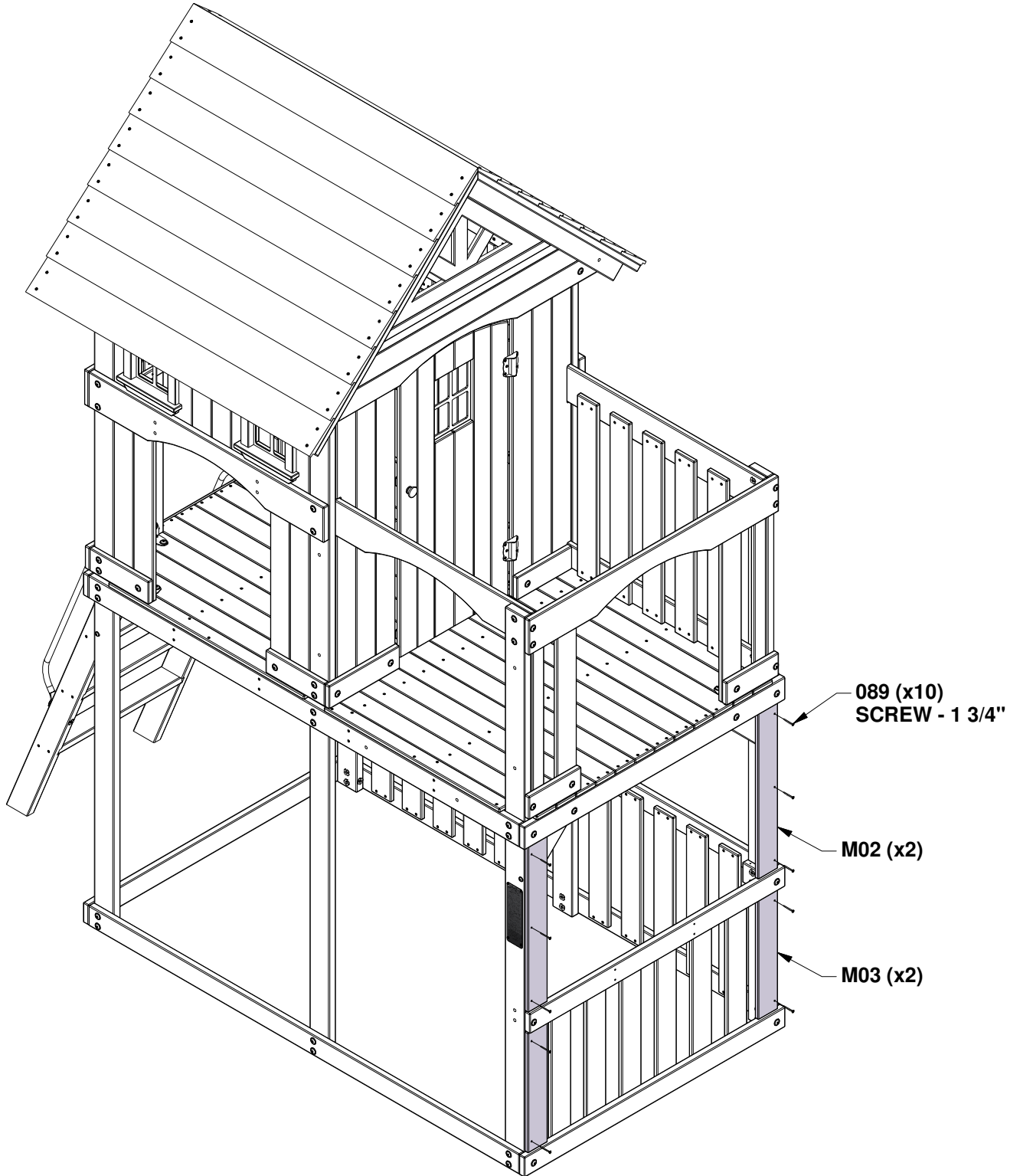

STEP 25 - FORT ASSEMBLY

QTY	PART NUMBER	DESCRIPTION
2	H100012	BOLT WH 5/16x2
2	H100030	WASHER LOCK EXT 8x19
2	H100074	T-NUT 5/16
4	H100091	SCREW PFH 8x2 1/4

**PILOT HOLES UPWARD
WHEN INSTALLED.**

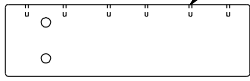

HB06 CLEAT - W4L22171
(x1) 1"x3"x10 1/4" (24x76x259)

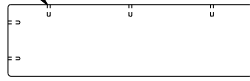

HB07 CLEAT - W4L22170
(x2) 1"x3"x10 1/4" (24x76x259)

**INSTALL T-NUTS IN WOOD FIRST.
ALIGN PILOT HOLES.**

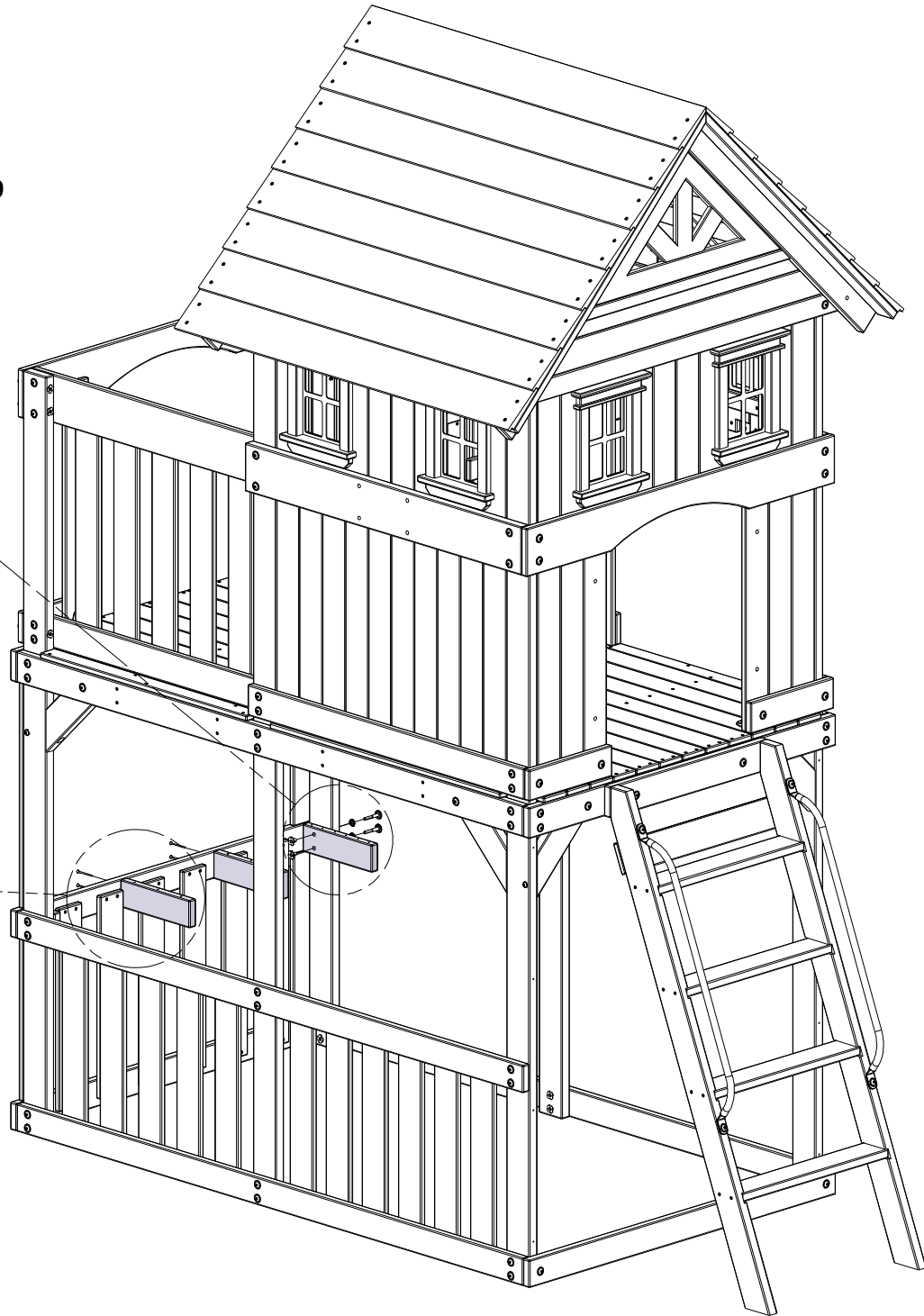
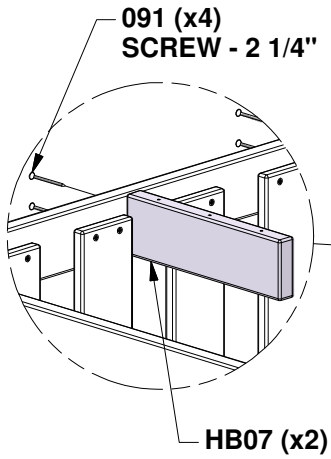
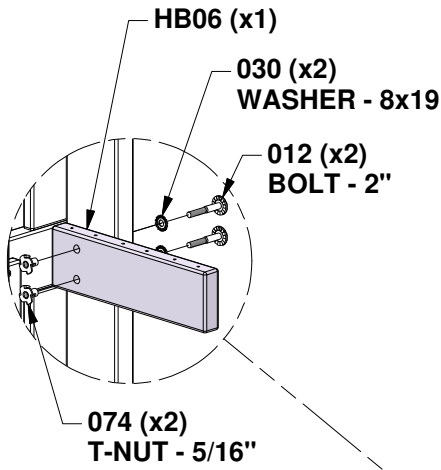

STEP 26 - FORT ASSEMBLY

QTY	PART NUMBER	DESCRIPTION
18	H100087	SCREW PFH 8x1-1/4



CT01 COUNTER TOP - W2A05008
(x1) 13/16"x11 1/8"x43 1/16" (21x283x1093)

ALIGN PILOT HOLES.

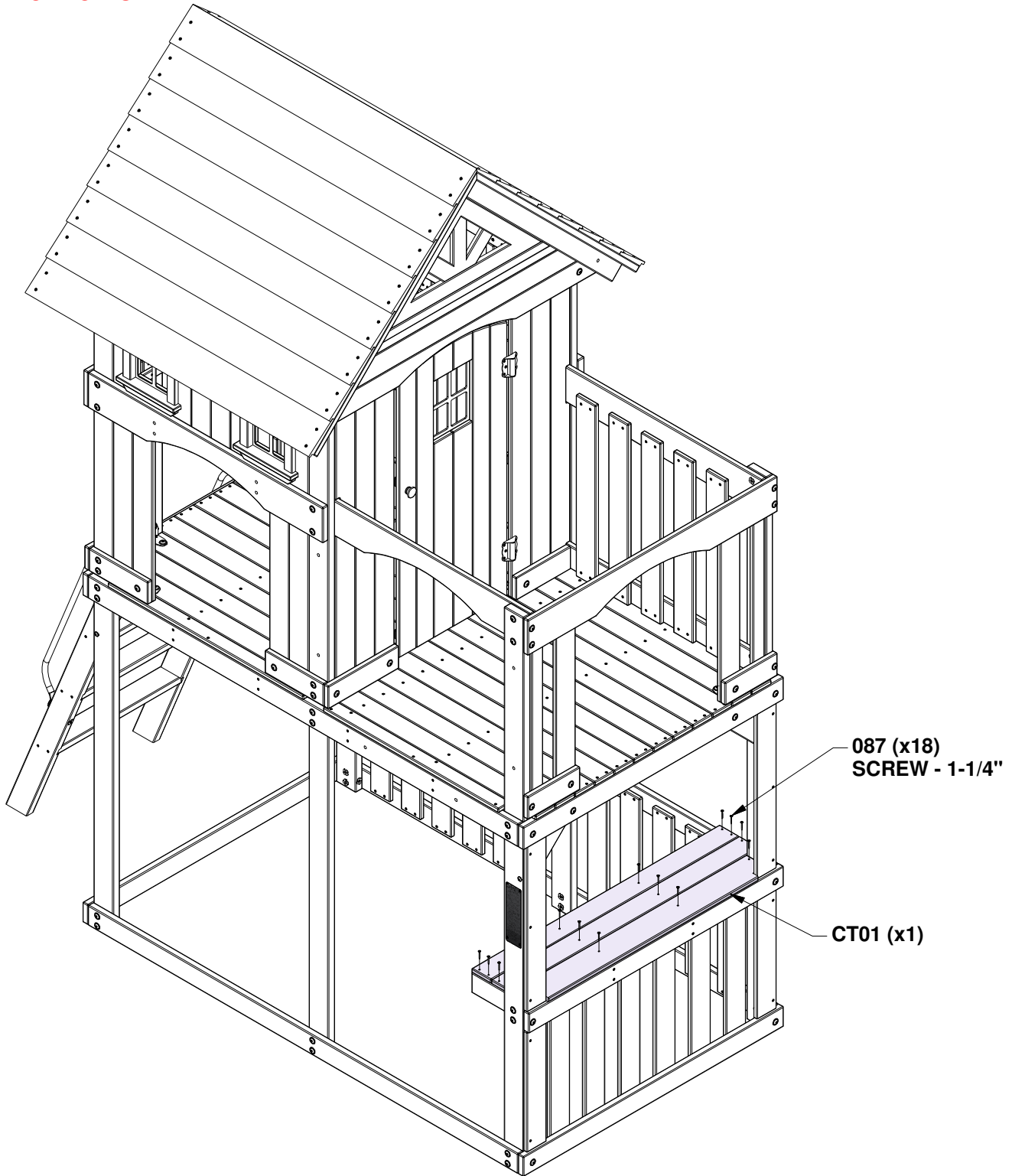

STEP 27 - FORT ASSEMBLY

QTY	PART NUMBER	DESCRIPTION
8	H100089	SCREW PFH 8x1-3/4



M01 UPRIGHT - W4L22141
(x2) 5/8"x3 3/8"x46" (16x86x1168)

ALIGN PILOT HOLES.

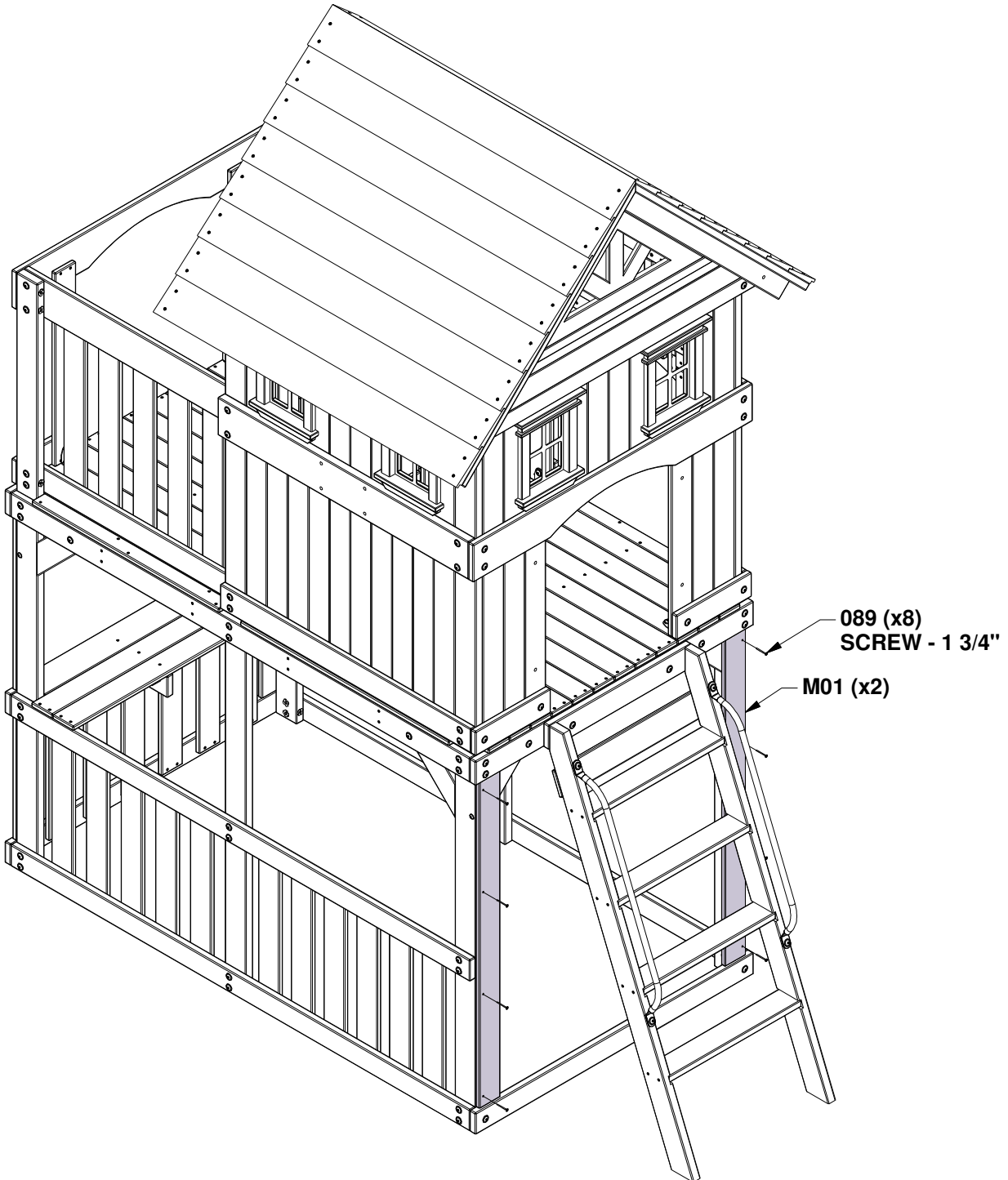

STEP 28 - FORT ASSEMBLY

QTY	PART NUMBER	DESCRIPTION
4	H100009	BOLT WH 5/16x1 1/4
8	H100074	T-NUT 5/16
4	H100115	BOLT WH 5/16x1/2

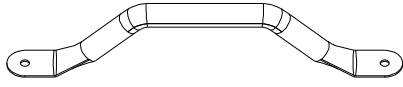

A100118 HAND GRIP METAL GREEN 381 c/c
(x4)

INSTALL T-NUTS IN WOOD FIRST

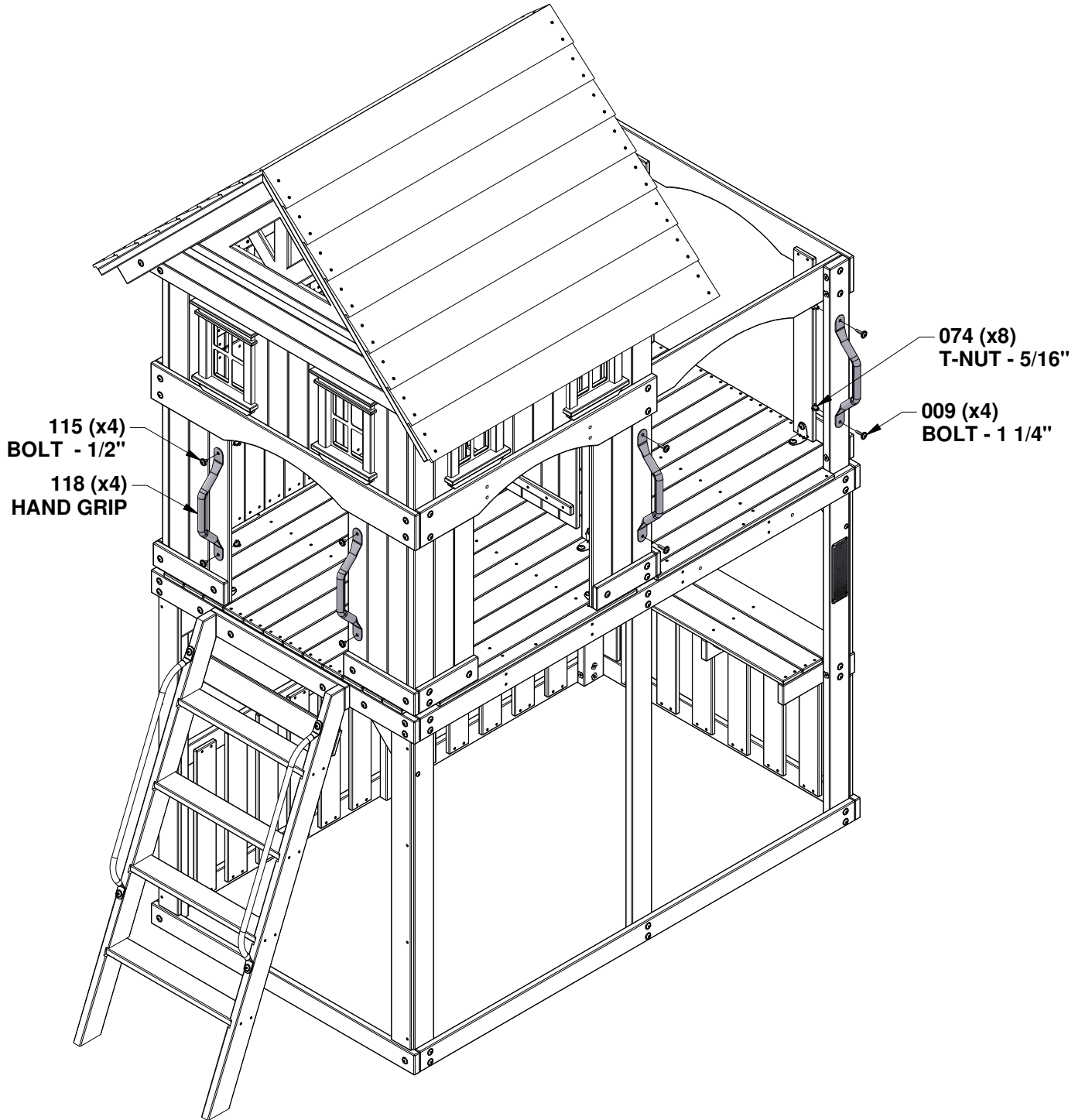

STEP 29 - FORT ASSEMBLY

QTY	PART NUMBER	DESCRIPTION
2	H100011	BOLT WH 5/16x1 3/4
2	H100030	WASHER LOCK EXT 8x19

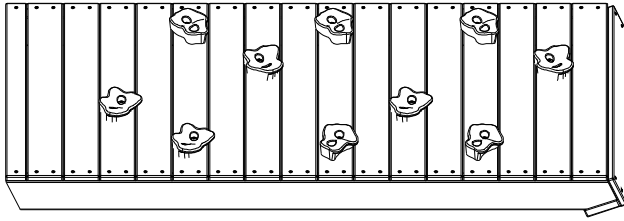

RW01 ROCK WALL
(x1)

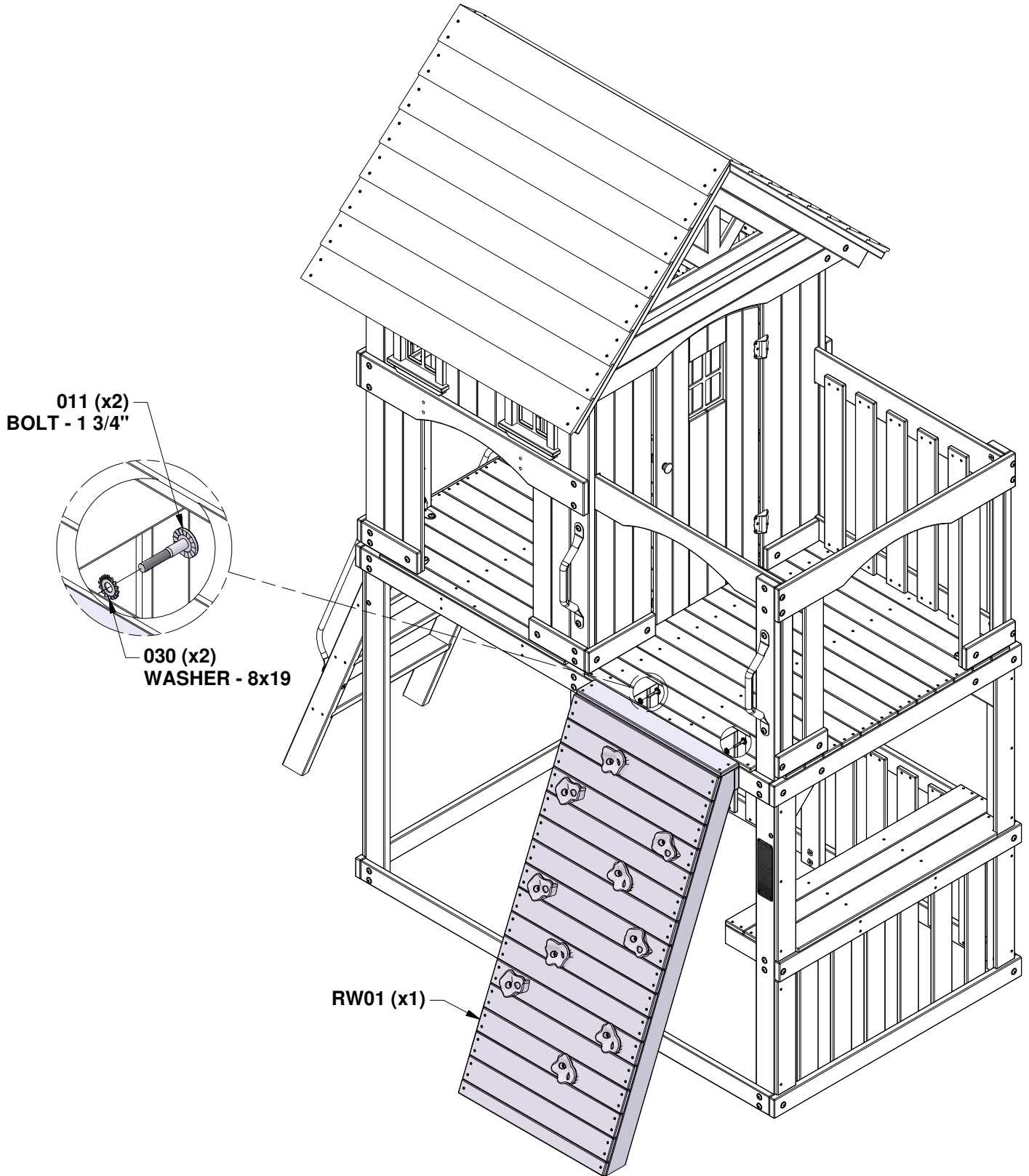

STEP 30 - FORT ASSEMBLY

QTY	PART NUMBER	DESCRIPTION
2	H100008	BOLT WH 5/16x1
2	H100074	T-NUT 5/16

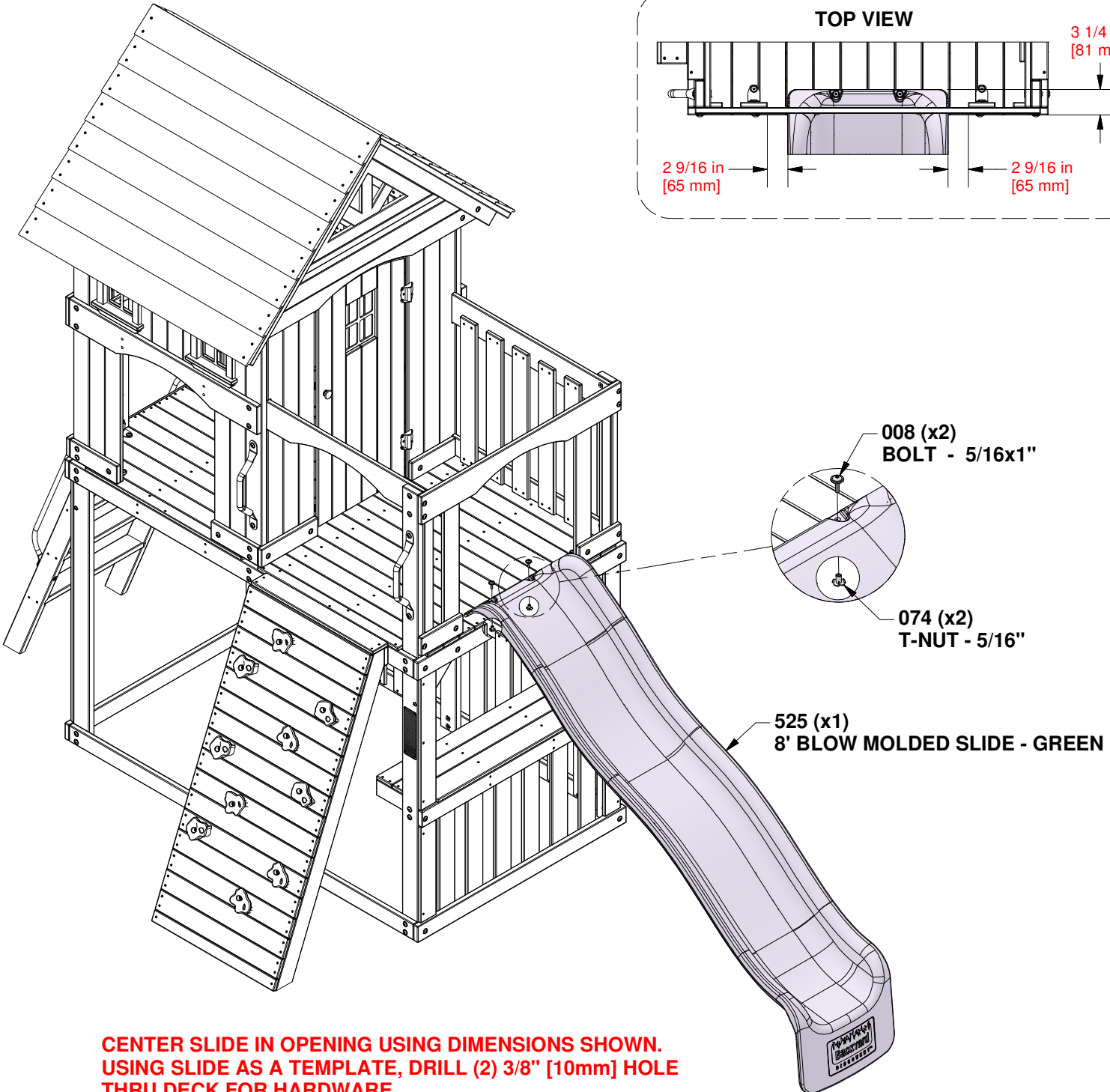
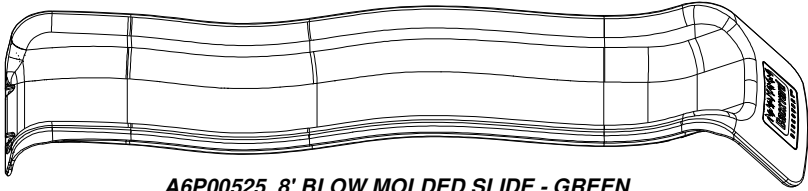

CENTER SLIDE IN OPENING USING DIMENSIONS SHOWN. USING SLIDE AS A TEMPLATE, DRILL (2) 3/8" [10mm] HOLE THRU DECK FOR HARDWARE.

STEP 31 - FORT ASSEMBLY

QTY	PART NUMBER	DESCRIPTION
4	H100008	BOLT WH 5/16x1
4	H100074	T-NUT 5/16

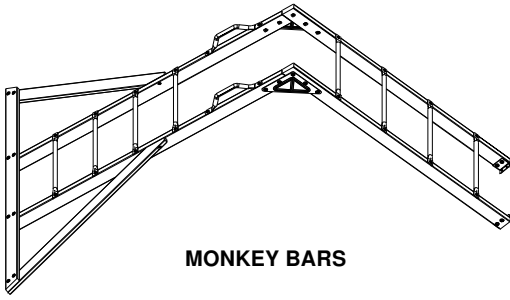

MONKEY BARS

INSTALL T-NUTS IN WOOD FIRST

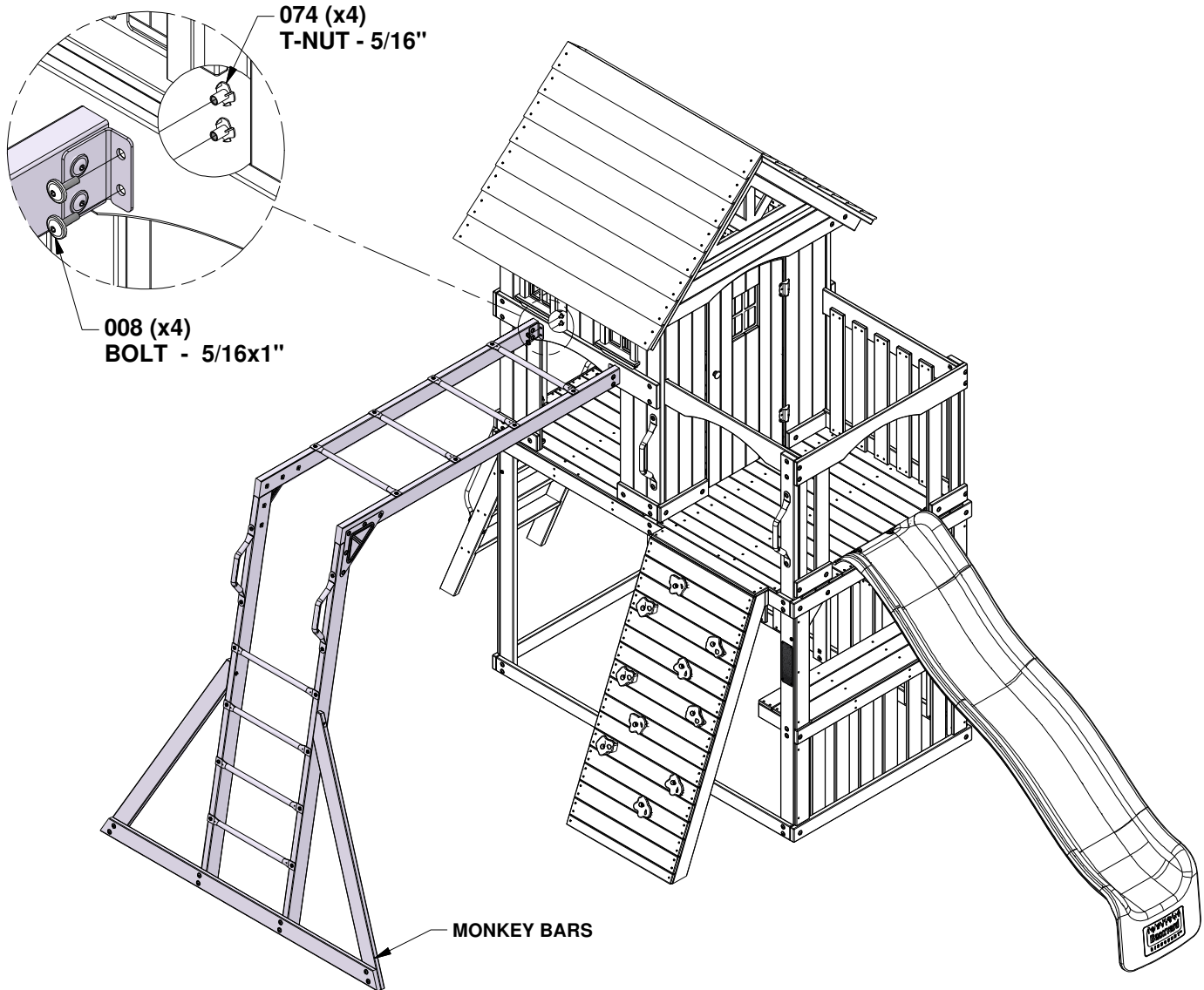

MONKEY BARS

STEP 32 - FORT ASSEMBLY

QTY	PART NUMBER	DESCRIPTION
4	H100042	BOLT HEX 5/16x1 1/4
4	H100074	T-NUT 5/16
4	H100095	WASHER SPLIT 5/16
4	H100105	WASHER FLAT 8x27

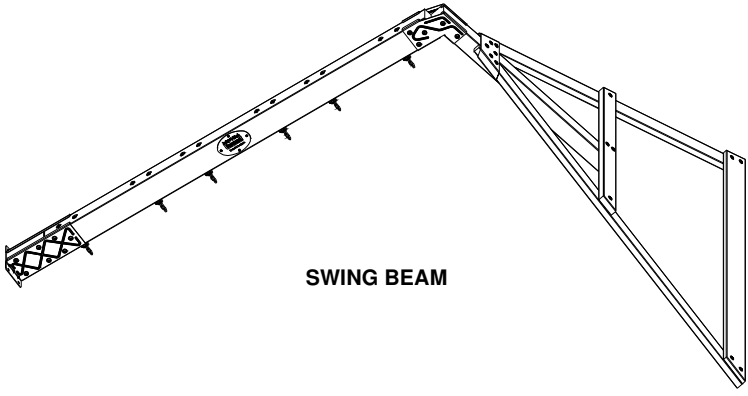

SWING BEAM

INSTALL T-NUTS IN WOOD FIRST

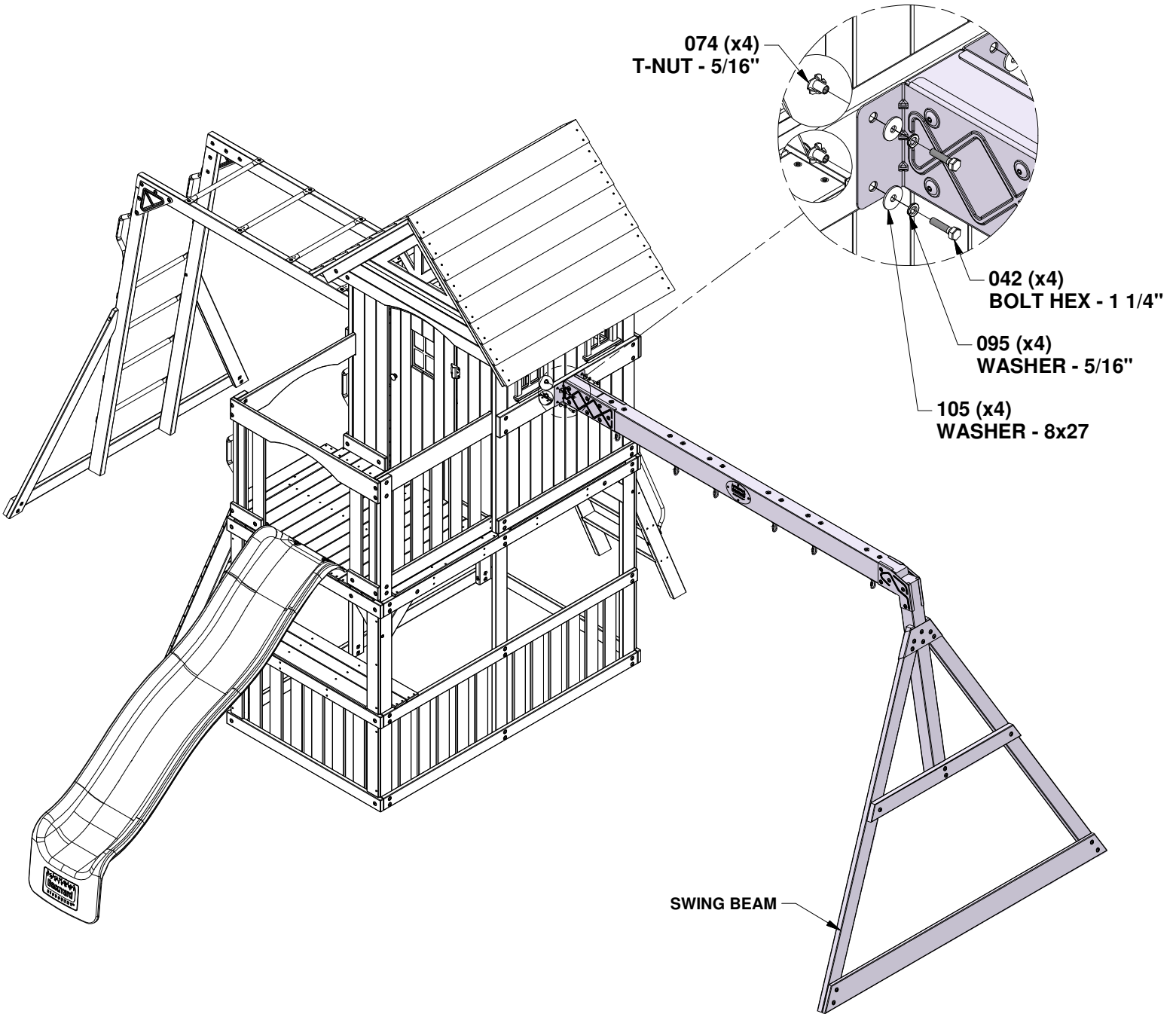

SWING BEAM

STEP 33 - FORT ASSEMBLY

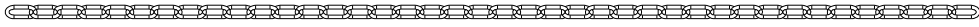

A100068 CHAIN GREEN 51.25"
(x4)



A6P00054 SWING SEAT GREEN 22"
(x2)



A100177 CHAIN GREEN 31"
(x2)

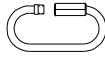

A100069 QUICK LINK
(x6)

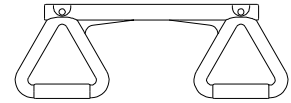

A6P00034 TRAPEZE YELLOW
(x1)

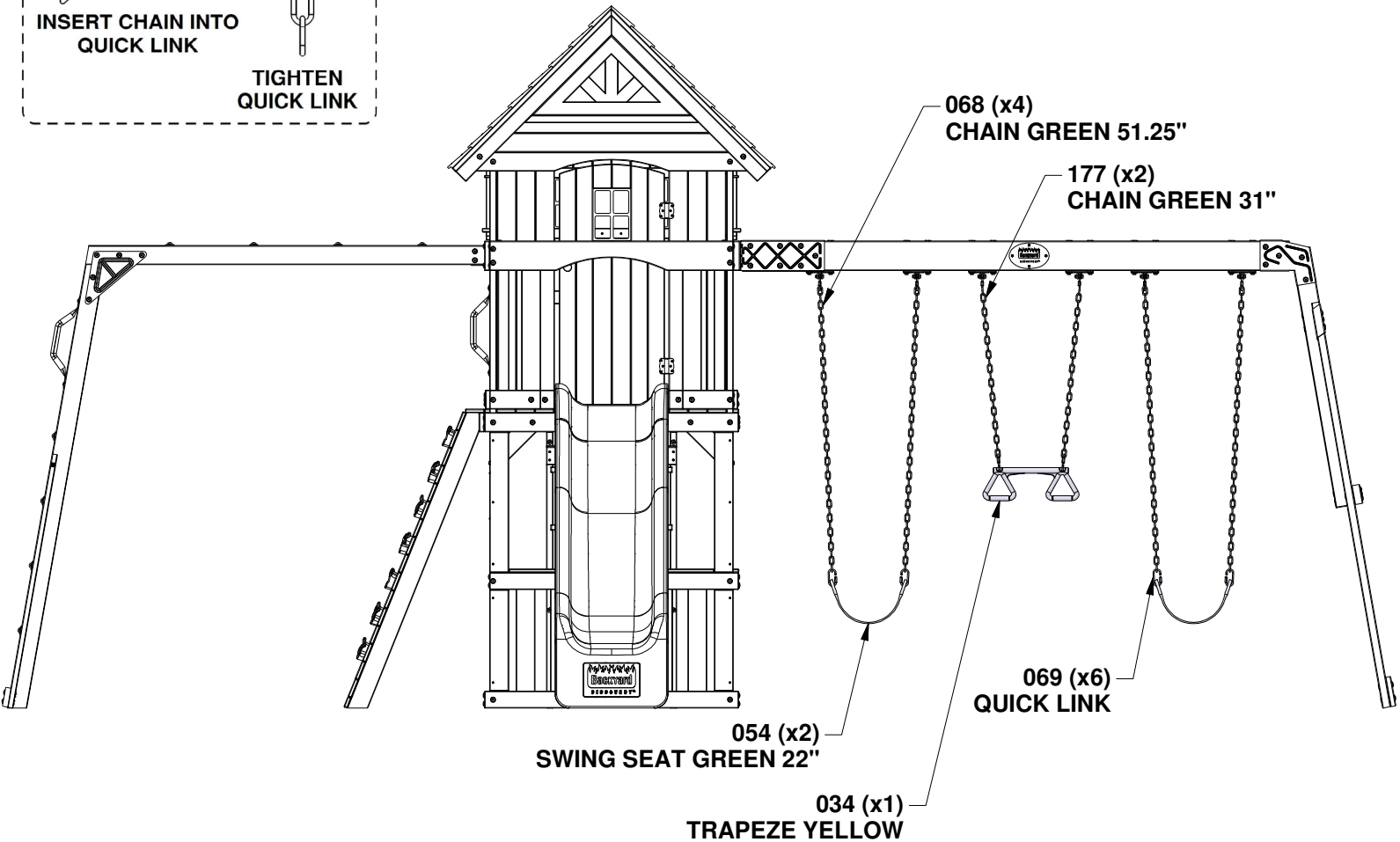
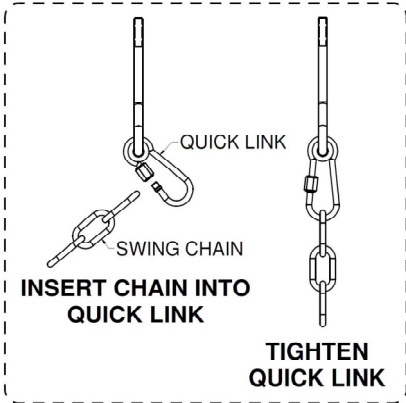

STEP 34 - FORT ASSEMBLY

QTY	PART NUMBER	DESCRIPTION
8	H100009	BOLT WH 5/16x1 1/4
8	H100074	T-NUT 5/16



A100178 AUGER GROUND STAKE
(x8)

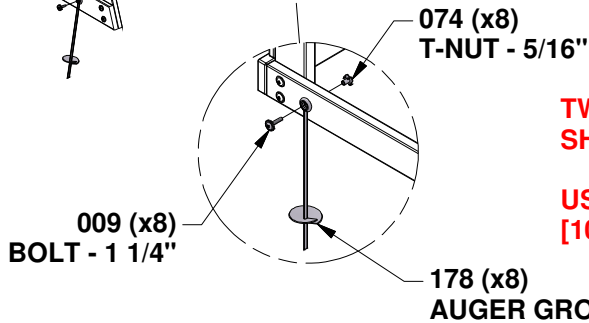
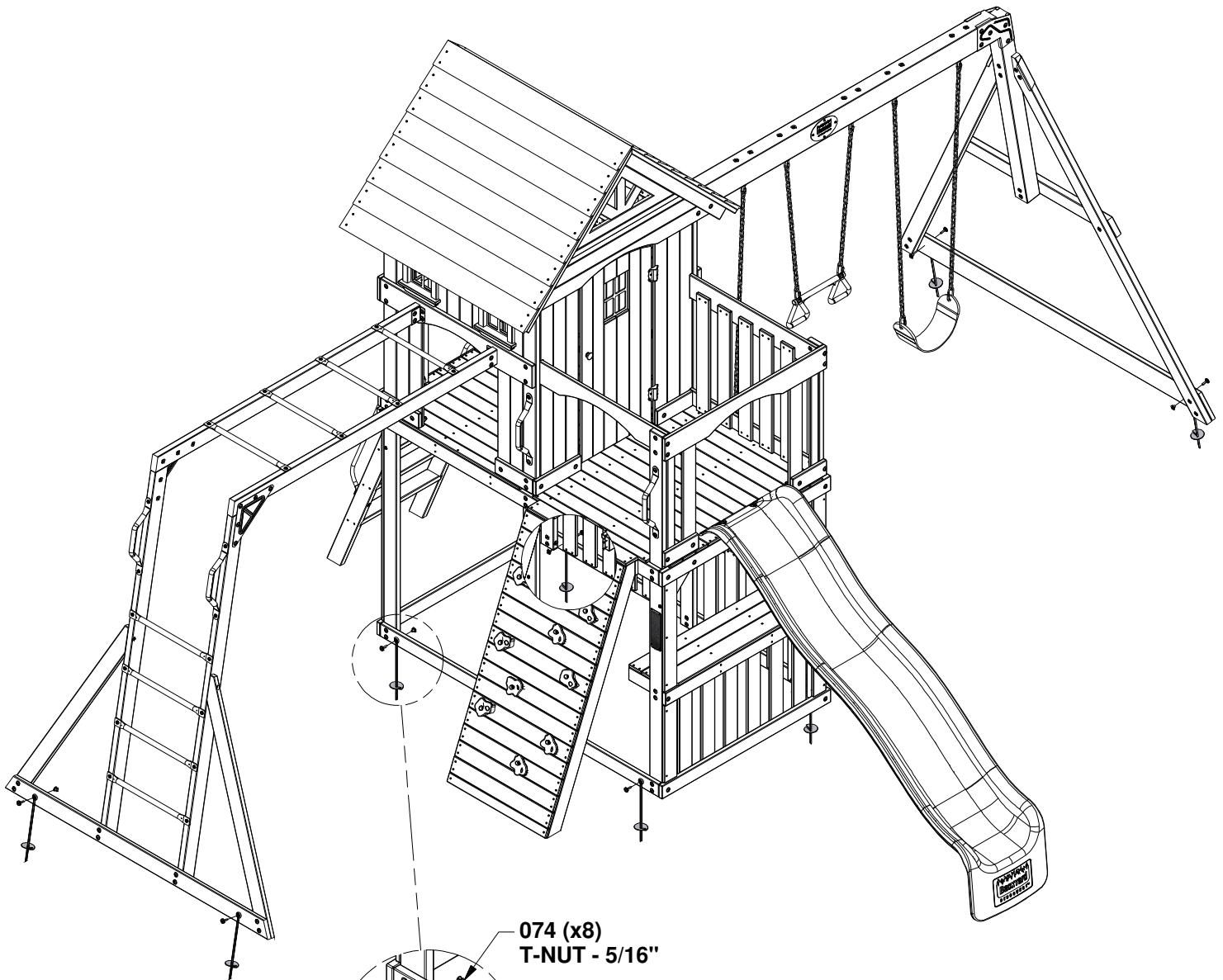

TWIST GROUND STAKES INTO GROUND WHERE SHOWN.

USING GROUND STAKE AS A GUIDE, DRILL (1) 3/8" [10 mm] HOLE FOR HARDWARE, EACH PLACE.