

BLACK DIAMOND®

Project Name: _____

Location: _____

Item #: _____

Qty: _____

Black Diamond Refrigerated Salad/Sandwich Prep Table, 2 Doors, 47", in Stainless Steel

GRSL-2D



Elevate your commercial kitchen with the Black Diamond Refrigerated Salad and Sandwich Prep Table, designed for efficiency and durability. Constructed with a stainless steel exterior and doors, this prep table offers a robust workspace. It features a 14 cubic feet capacity, maintaining temperatures between 33° and 40°F. The fully automatic controller ensures precise operation, while the R290 refrigerant supports eco-friendly cooling. Easy to clean and maintain, this unit is a reliable choice for any deli or cafe.

FEATURES AND CONSTRUCTION

- 14 Cu. Ft. capacity provides ample storage for ingredients
- Equipped with a 0.75 horsepower compressor for efficient cooling
- Constructed from high-quality stainless steel for durability
- Maintains a temperature range of 33° to 40°F for optimal food freshness
- Utilizes R290 refrigerant for eco-friendly operation
- Operates on 115V with a NEMA-5-15P plug for standard outlets
- Features adjustable shelving for customizable storage options
- Comes with four casters for easy mobility in any setting
- User-friendly design with a fully automatic temperature controller
- Includes a convenient cutting board for easy food preparation

ELECTRIC

115VV / 60Hz / 1Ph

Cord Length (Inches): 86.60

Plug Type: NEMA 5-15P

Cord set included

NEMA 5-15P



3RD PARTY APPROVALS



WARRANTY (USA / CANADA)

Two (2) Year Limited Warranty on Parts and Labor, Five (5) Year Warranty on Compressor and Evaporator

Contact us for details at 1.877.368.2797



STORAGE CAPACITY

- Cubic Feet: 14 Cu. Ft.

TEMPERATURE

- Holding Temperature (Fahrenheit): 33° - 40°

These models are designed to operate in an environment where temperature and humidity do not exceed 75°F (24°C) and 55% relative humidity



Black Diamond 2 Door Refrigerated Salad/Sandwich Prep Table - 47"

GRSL-2D

FRONT

SIDE

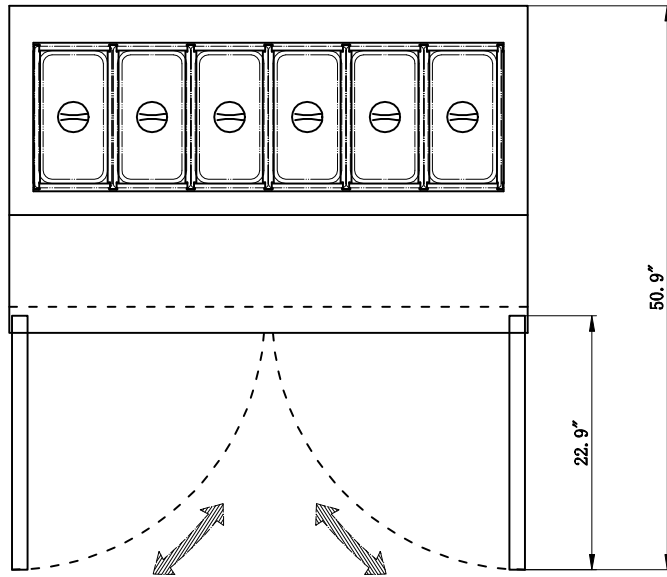
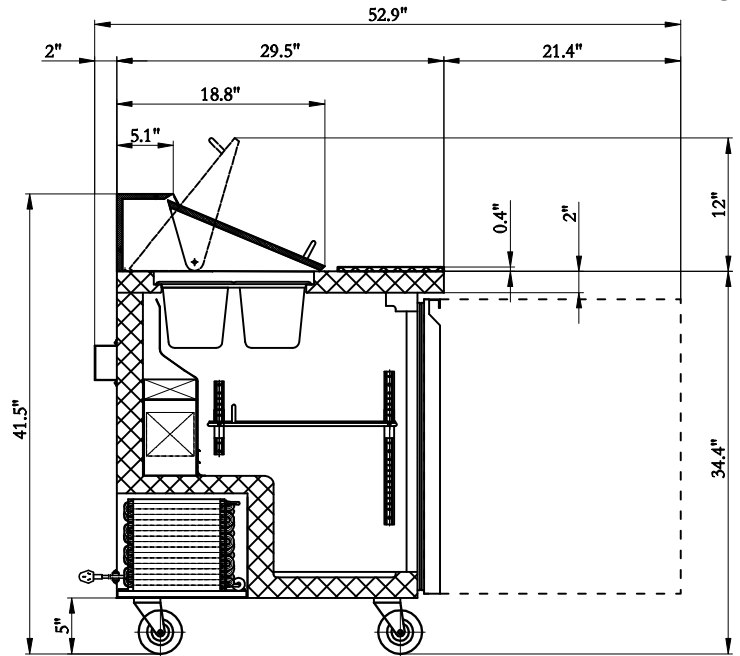
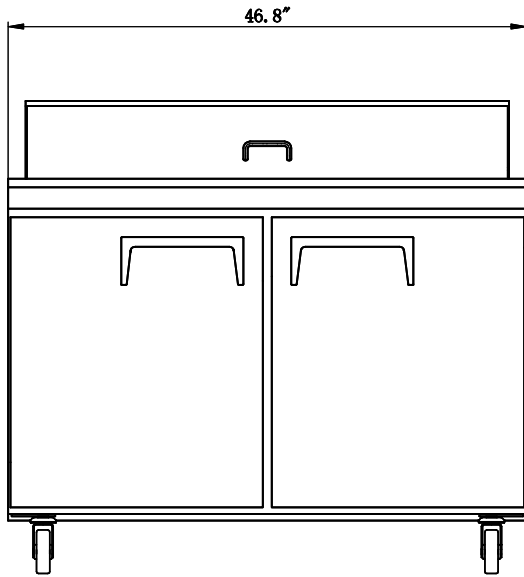

TOP

Prep Table

Doors	Shelves	Amps	HP	Refrigerant	Capacity	Assembled Dimensions (in)	Item Weight (lbs)	Shipping Weight (lbs)
2	2	4.9A	1/4	R290 3.883	14 Cu. Ft.	46.70" x 29.50" x 42.30"	253.0	304.0

Due to periodic changes in designs, methods, procedures, policies and regulations, the specifications contained in this document are subject to change without notice. While we exercise good faith efforts to provide information that is accurate, we are not responsible for errors or omissions in information provided or conclusions reached as a result of using the specifications. By using the information provided, the user assumes all risks in connection with such use.