

Item: LEEBD-T

Assembly Instructions



Please visit our website for the most current instructions, assembly tips, to report damage or request parts. www.walkeredison.com

Revised 05/2024-V2

General assembly guidelines

- I. Ensure that all parts and hardware are available before beginning assembly.
- II. Follow each step carefully to ensure the proper assembly of this product.
- III. Two people are recommended for ease in the assembly of this product.
- IV. The three main types of hardware used to assemble this product are wood dowels, screws and bolts.
- V. A phillips head screwdriver, hammer and tape measure is required for the assembly of this product.

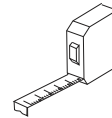
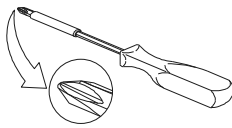
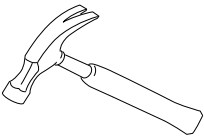

- VI. Power tools should not be used to assemble this product.

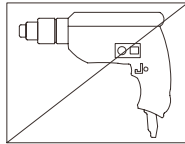

VII. Maintenance Guide

To maintain long term performance and easy gliding of your solid wood drawers, we recommend applying wax to the wooden guide rails.

1. Bee's wax is recommended or Paraffin wax from a standard candle can be used.
2. Apply the wax by rubbing it on the wooden guide rails where there is wood-on-wood contact when opening and closing the drawer. (Wax should be room temperature, do not melt the wax onto the wood)
3. Wax should be applied every few months for the first year and then only when needed after that to keep the drawers sliding smoothly.

Parts List

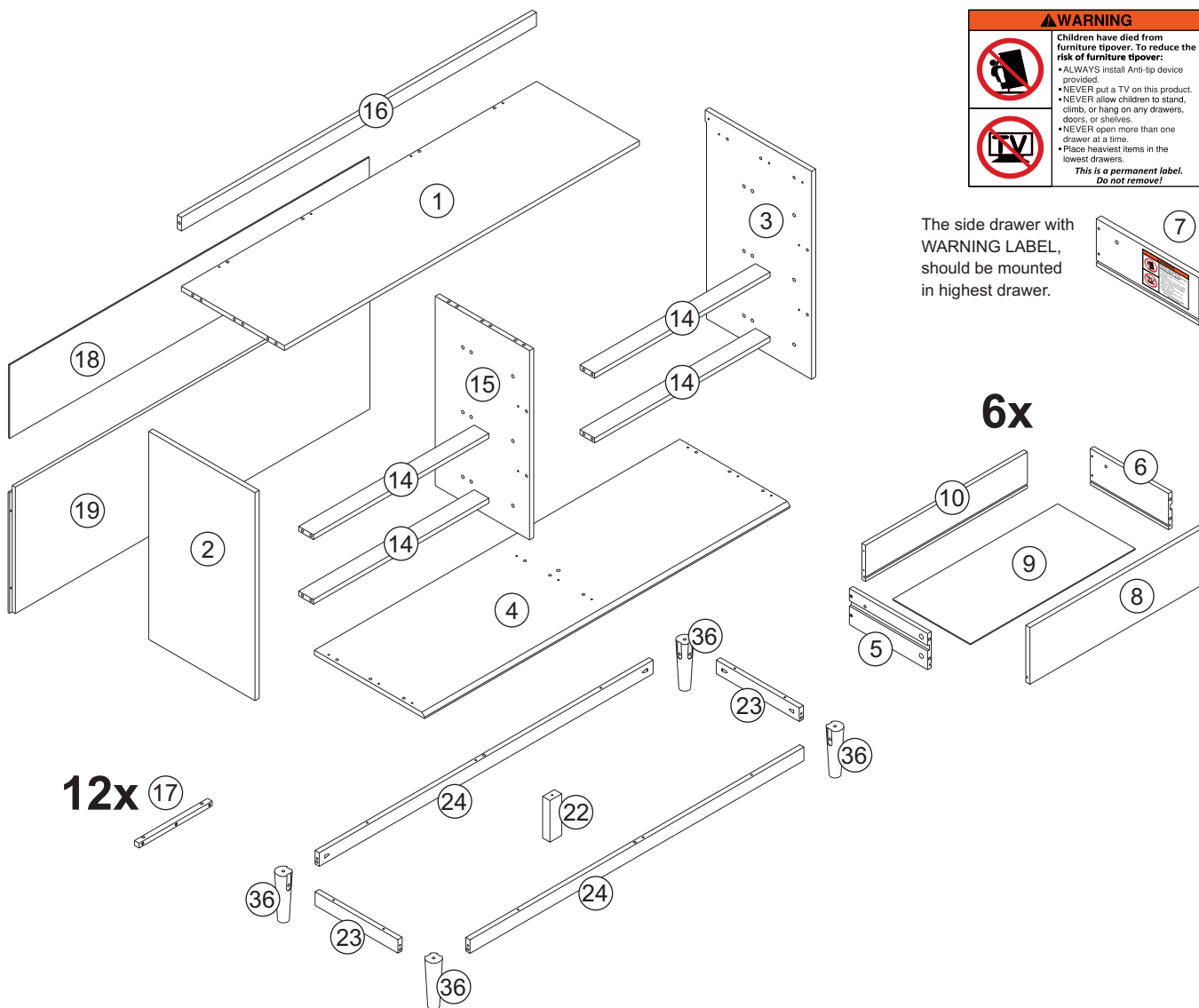

WARNING

Children have died from furniture tipover. To reduce the risk of furniture tipover:

- ALWAYS install Anti-tip device provided.
- NEVER put a TV on this product.
- NEVER allow children to stand, climb, or hang on any drawers, doors, or shelves.
- NEVER open more than one drawer at a time.
- Place heaviest items in the lowest drawers.











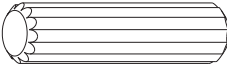
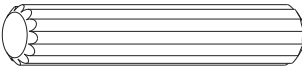
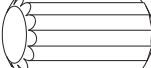

This is a permanent label. Do not remove!

The side drawer with WARNING LABEL, should be mounted in highest drawer.

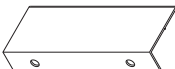
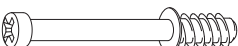
Part #	Description	Qty
1	Top panel	01 pc
2	Left side panel	01 pc
3	Right side panel	01 pc
4	Base	01 pc
5	Left drawer side	06 pcs
6	Right drawer side	05 pcs
7	Right drawer side (warning)	01 pc
8	Drawer front	06 pcs
9	Drawer bottom	06 pcs
10	Drawer back	06 pcs

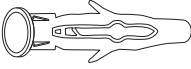
Part #	Description	Qty
14	Front rail	04 pcs
15	Division	01 pc
16	Top rail	01 pc
17	Wood slider	12pcs
18	Back Panel	01 pc
19	Bottom back panel	01 pc
22	Central foot	01 pc
23	Bottom side rail	02 pcs
24	Bottom front rail	02 pcs
36	Foot	04 pcs

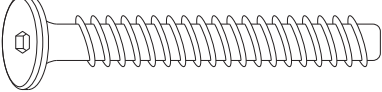
Hardware List

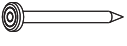
A		Ø8*30mm	Wood dowel	57 pcs
B		Ø8*40mm	Wood dowel	12 pcs
C		Ø10*20mm	Wood dowel	36 pcs
D		Ø3,0*12mm	Screw	24 pcs
E		Ø3,5*20mm	Screw	05 pcs
F		Ø4,0*25mm	Screw	36 pcs
G		Ø4,0*30mm	Screw	29 pcs
H		Ø4,0*40mm	Screw	27 pcs
J		-	Handle	12 pcs
K		Ø8,0*31mm	Cam bolt	43 pcs
L		Ø15*11mm	Cam lock	43 pcs
M		-	Ø6mm	01 pc
N		-	Washer	02 pcs
O		-	Wall anchor	01 pc
P		Ø7,0*50mm	Screw	01 pc
Q		-	Hex Key	01 pc
R		Ø8,0*8mm	Nail	20 pcs

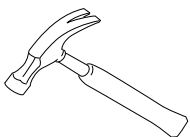

Hammer recommended for assembly (not included)

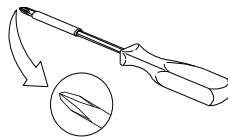

Phillips head screwdriver required for assembly (not included)

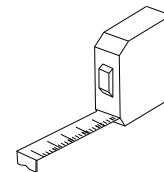

Tape measure required for assembly (not included)

The hardware quantities listed above are required for proper assembly. Some extra hardware may also have been included.

Step 1

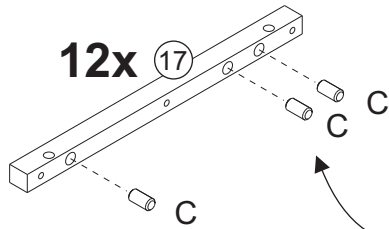

Attention to the
dowel size:
Ø10*20mm

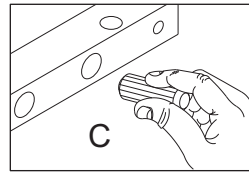
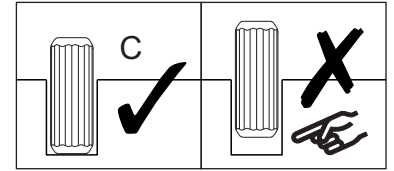

Insert wood dowel (C) into part 17.

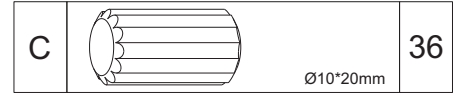

Step 2

Please assemble on
a clean soft surface
to avoid damage.

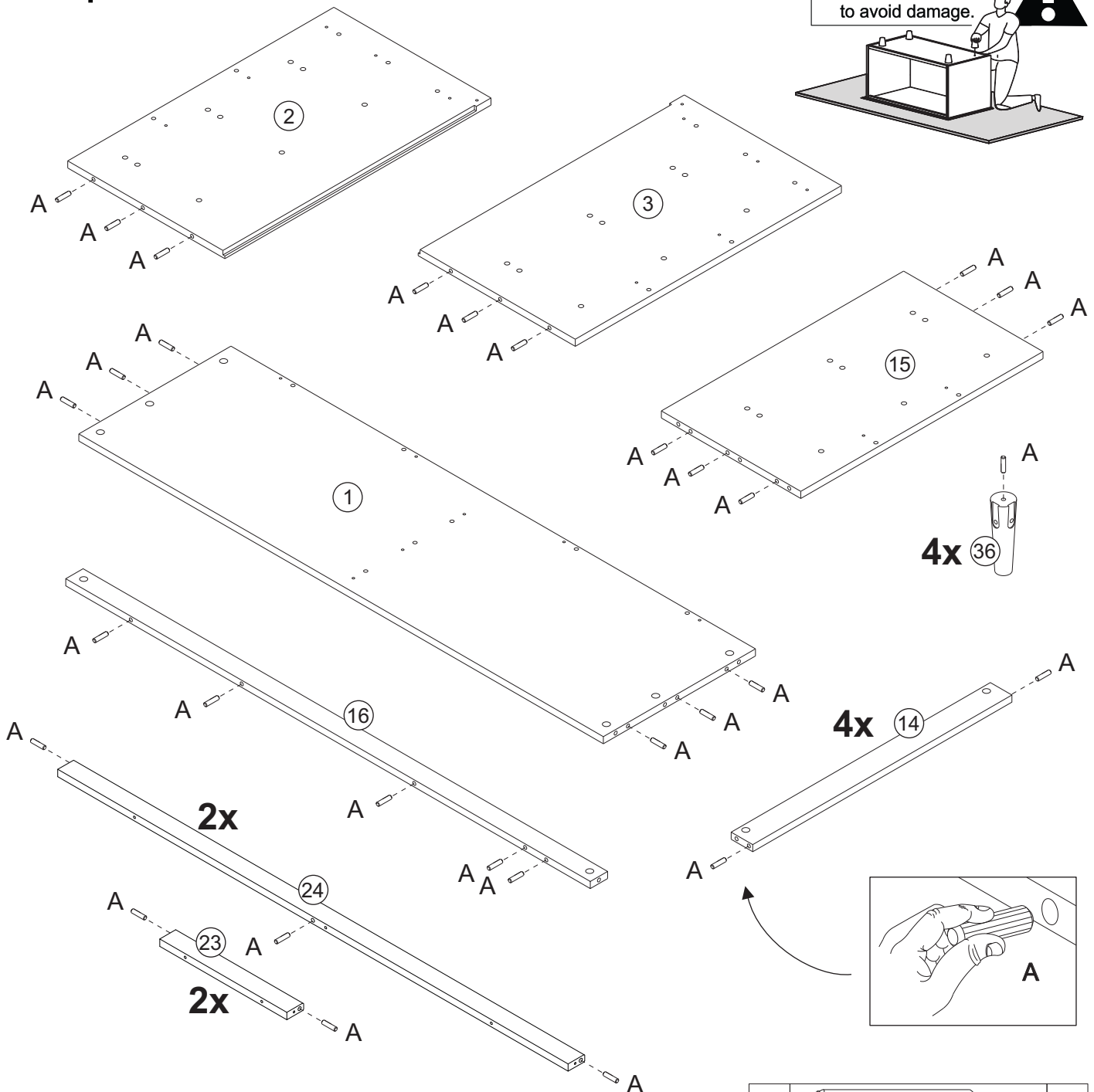

Insert wood dowel (A) into parts 1, 2, 3, 14, 15, 16, 23, 24 and 36.

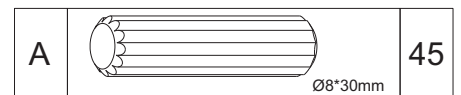

Step 3

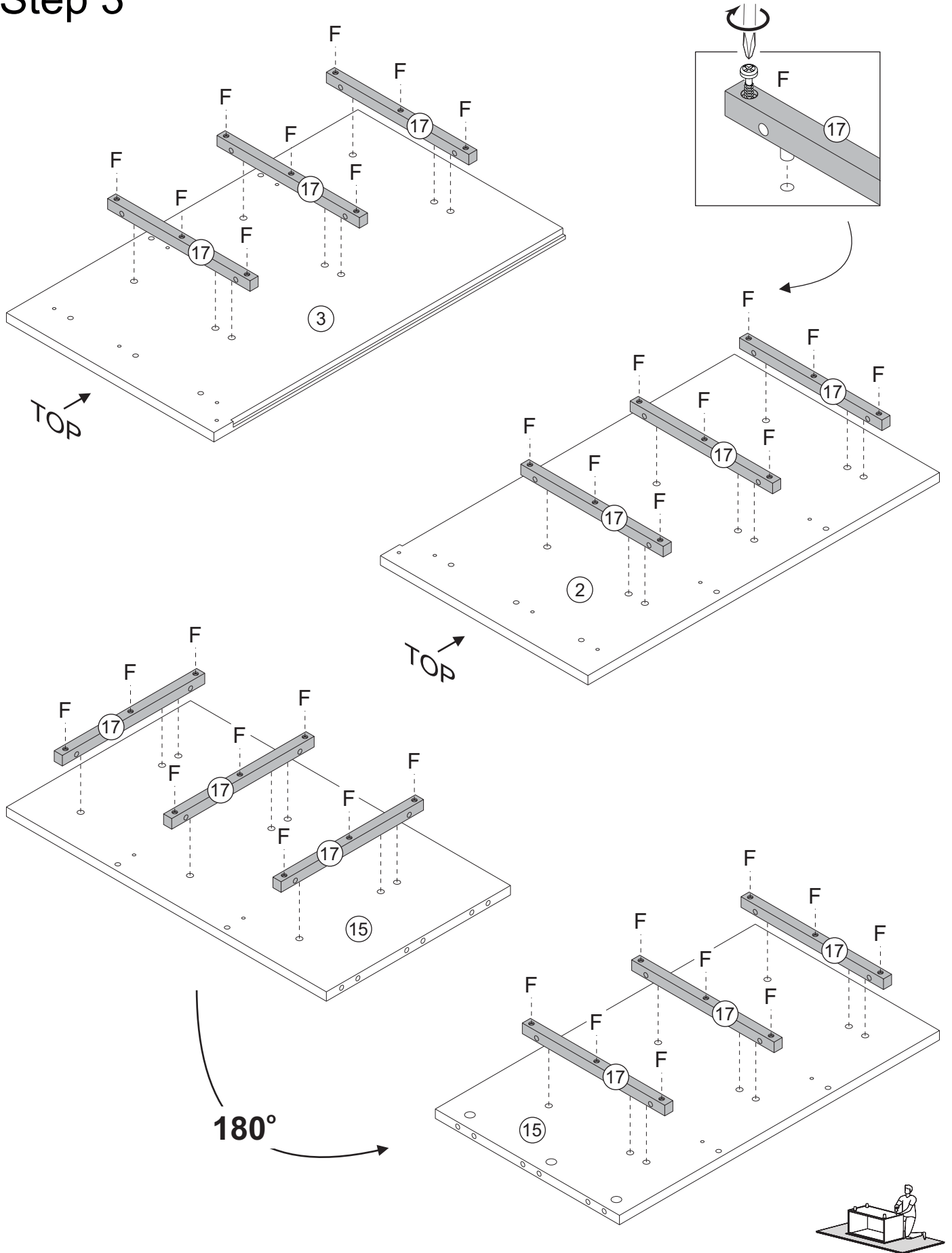

Secure parts 17 to part 2, 3 and 15 with screw (F) and phillips head screwdriver.

F		36
		Ø4,0*25mm

Step 4

1 - Ensure cam bolt is installed straight and not at an angle.
 2 - Tighten cam bolt until shoulder on cam bolt is flush. Do not over-tighten.

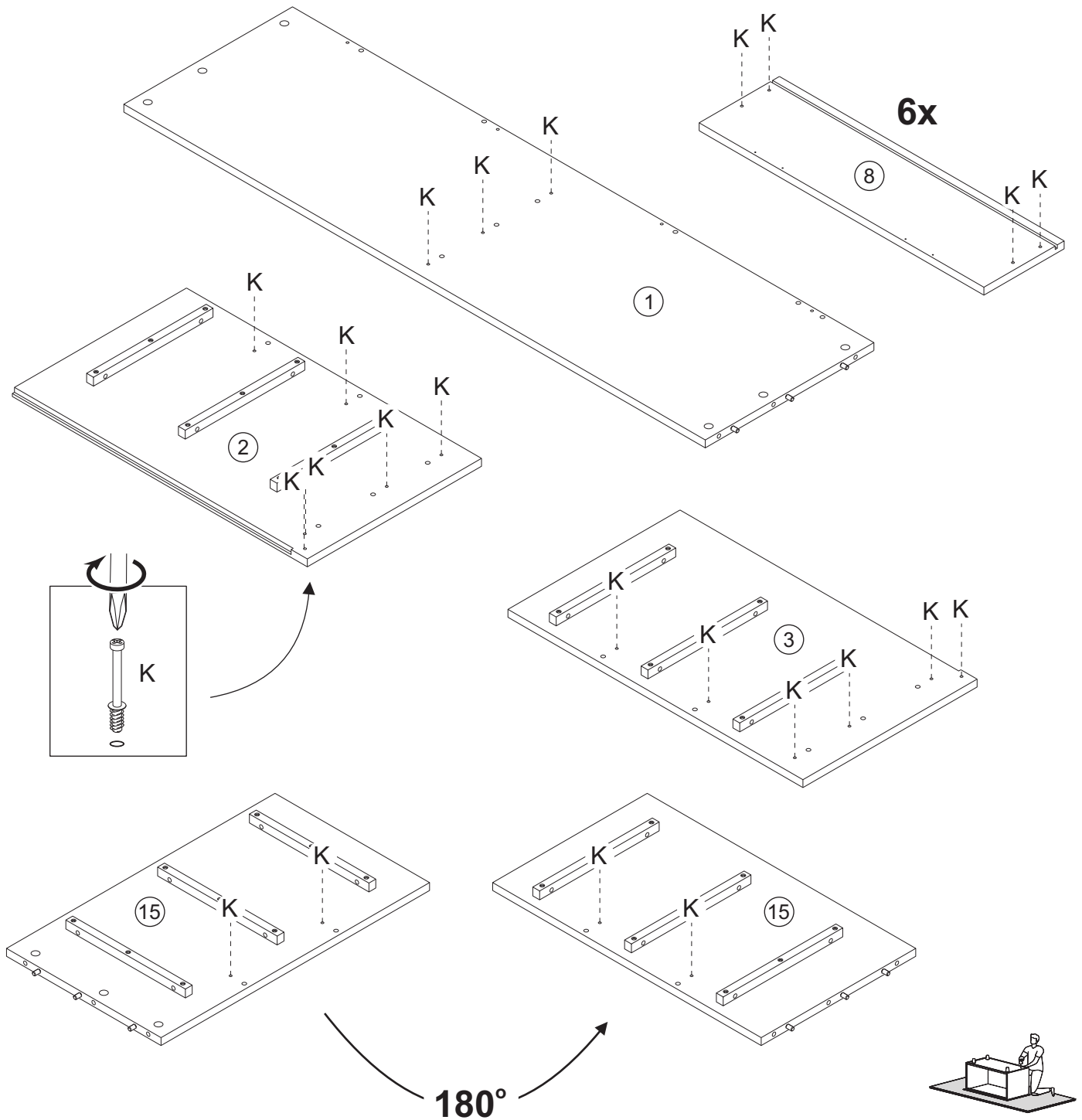
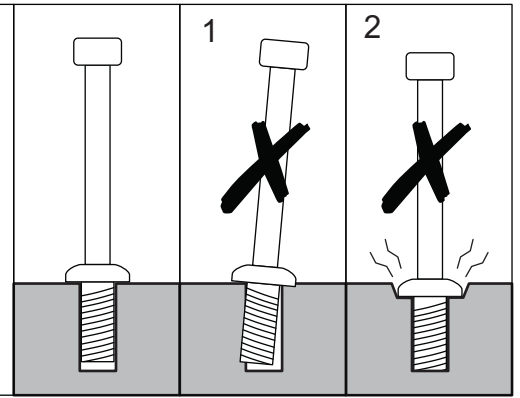

Screw cam bolts (K) into parts 1, 2, 3, 8 and 15 with a phillips head screwdriver.

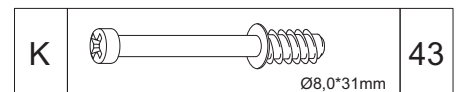

Step 5

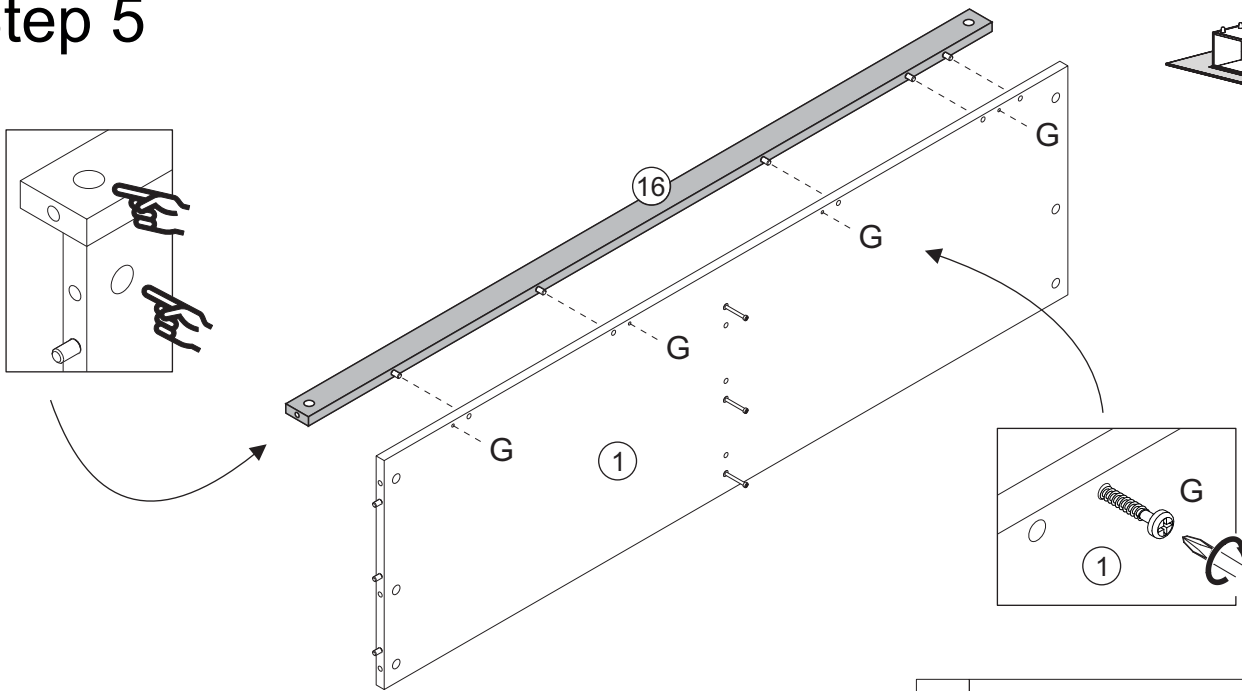

Secure part 16 to part 1 with screw (G) and phillips head screwdriver.

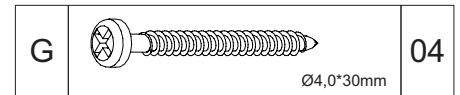

Step 6

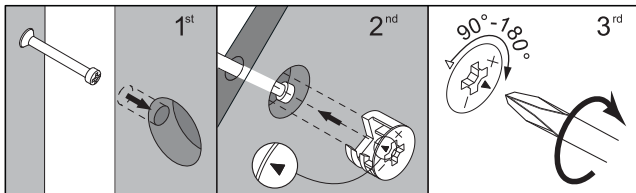

Align the opening in cam lock to the cam bolt and press into opening. Using a screwdriver, rotate the cam lock until it engages with the cam bolt and locks in place (anywhere between 90-180 degrees). Do not over-tighten the cam lock. Doing so may result in damaged or broken parts.

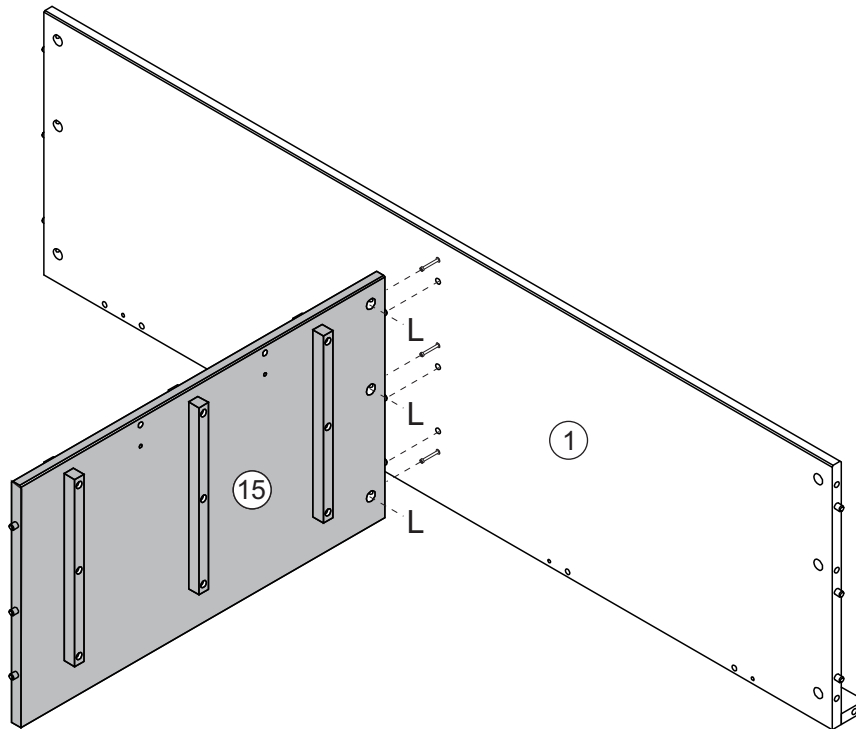

Secure part 15 to part 1. Insert cam locks (L) into part 15, and tighten with a phillips head screwdriver.



Step 7

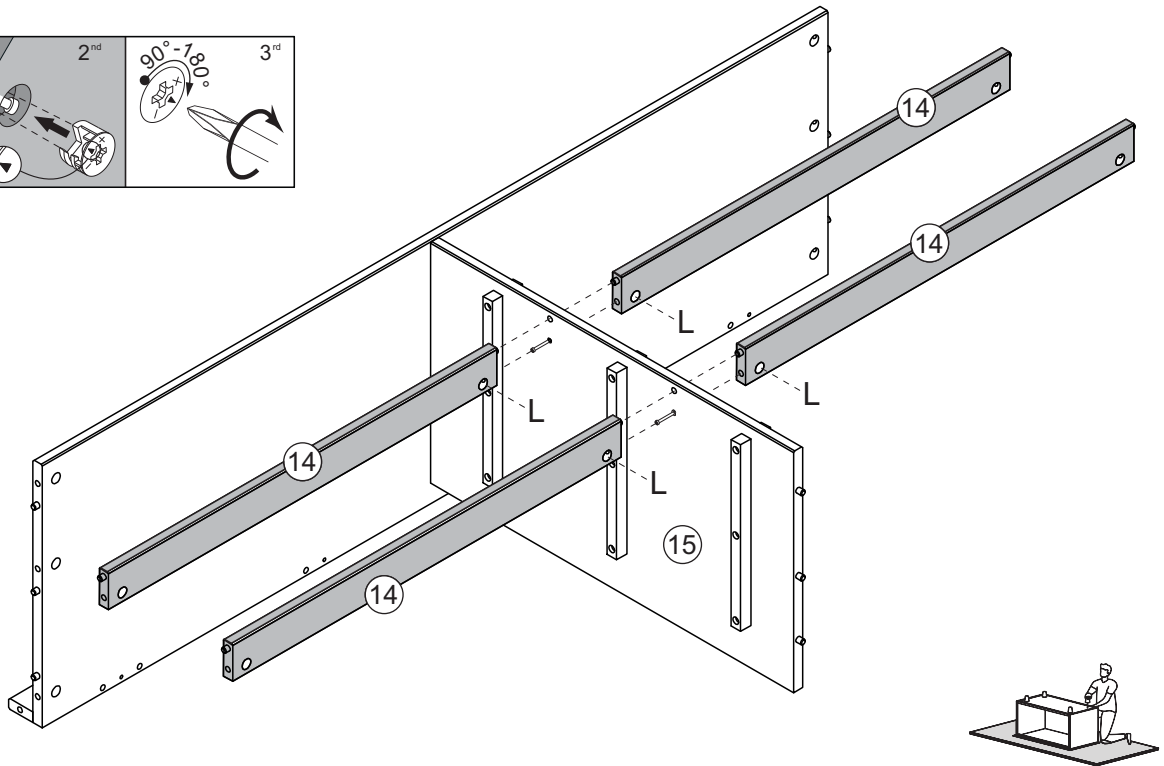
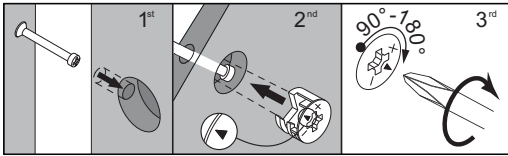

Secure part 14 to part 15. Insert cam locks (L) into part 14, and tighten with a phillips head screwdriver.



Step 8

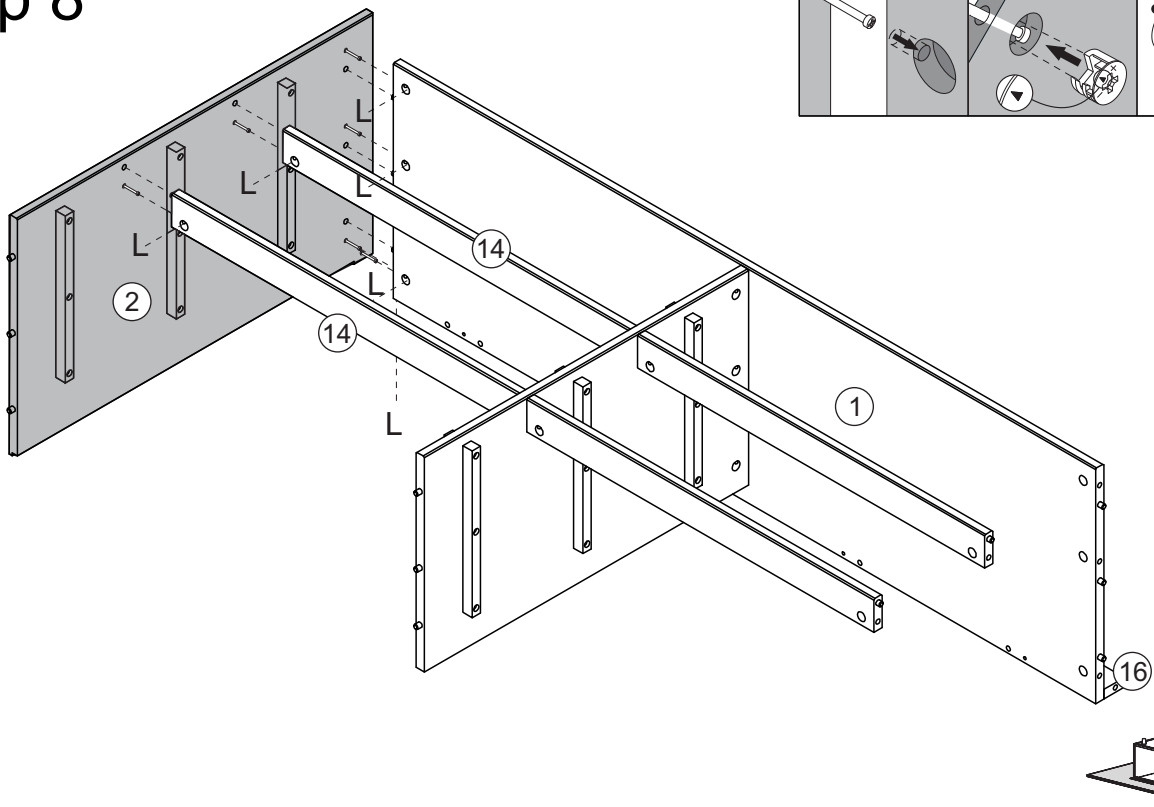
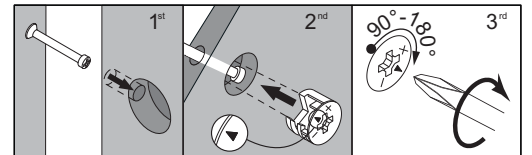

Secure parts 1, 14 and 16 to part 2. Insert cam locks (L) into parts 1, 14, 16, and tighten with a phillips head screwdriver.



Step 9

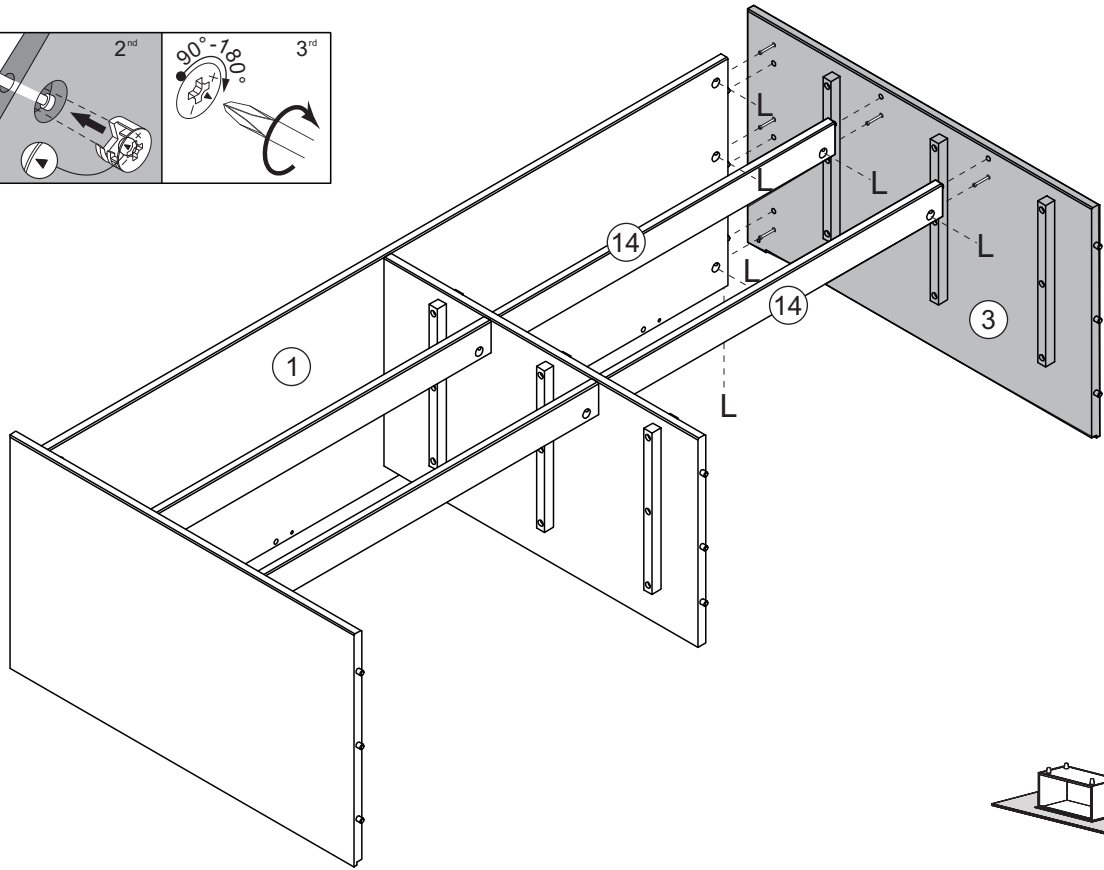
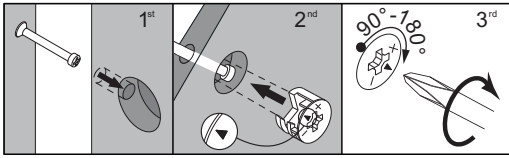

Secure parts 1 and 14 to part 3. Insert cam locks (L) into parts 1, 14, 16, and tighten with a phillips head screwdriver.

L		Ø15*11mm	06
---	--	----------	----

Step 10

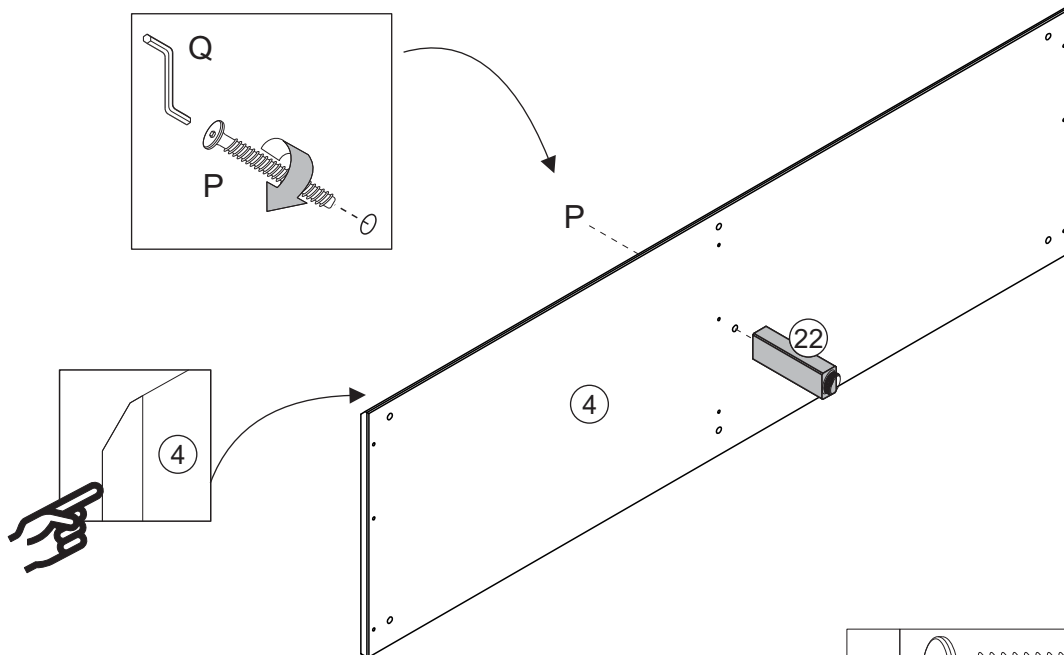

Attach part 22 to part 4 with screw (P) and hex key (Q).

P		Ø7,0*50mm	01
Q			01

Step 11

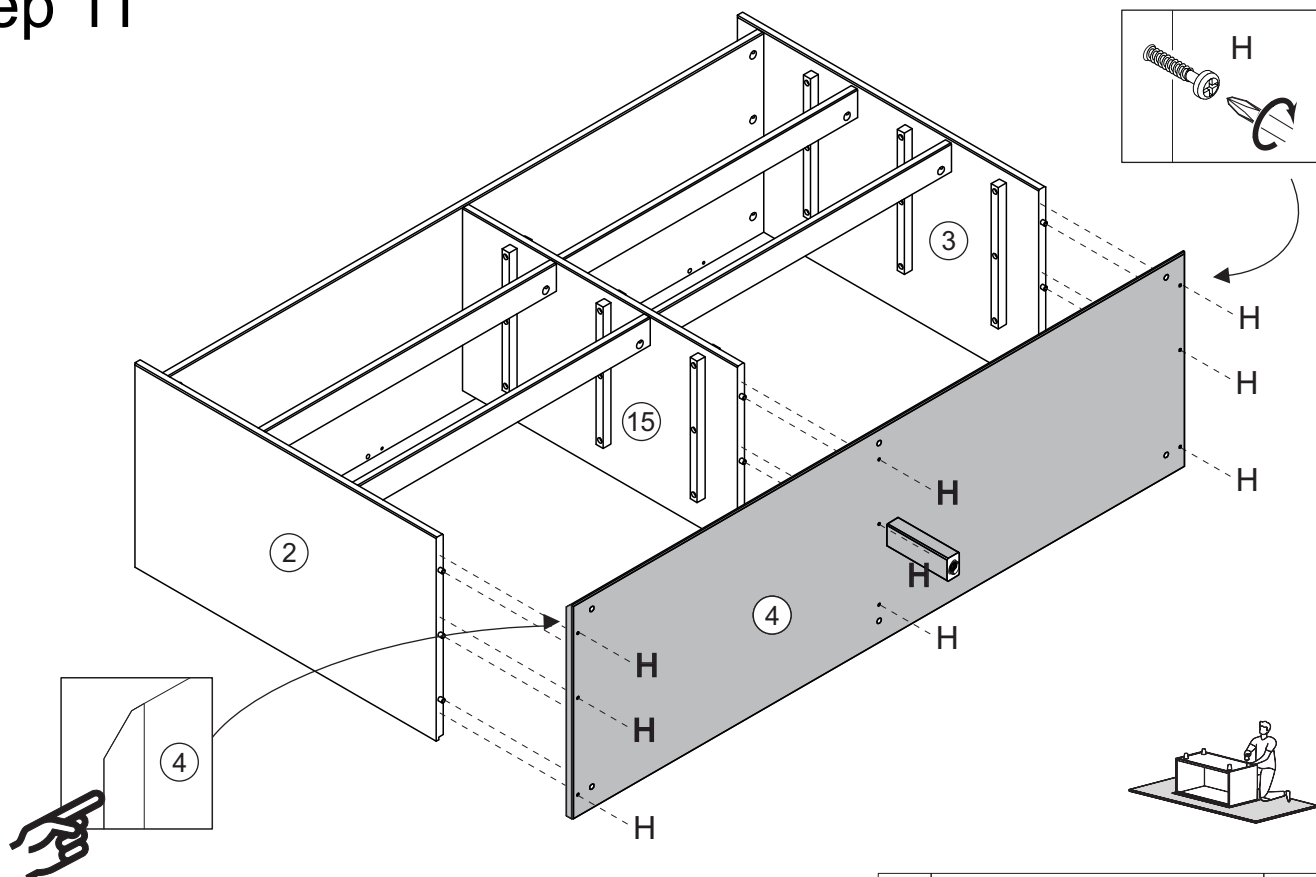

Secure part 4 to parts 2, 3 and 15 with screw (H) and phillips head screwdriver.

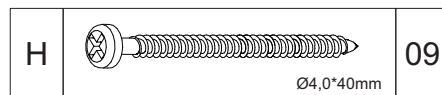

Step 12

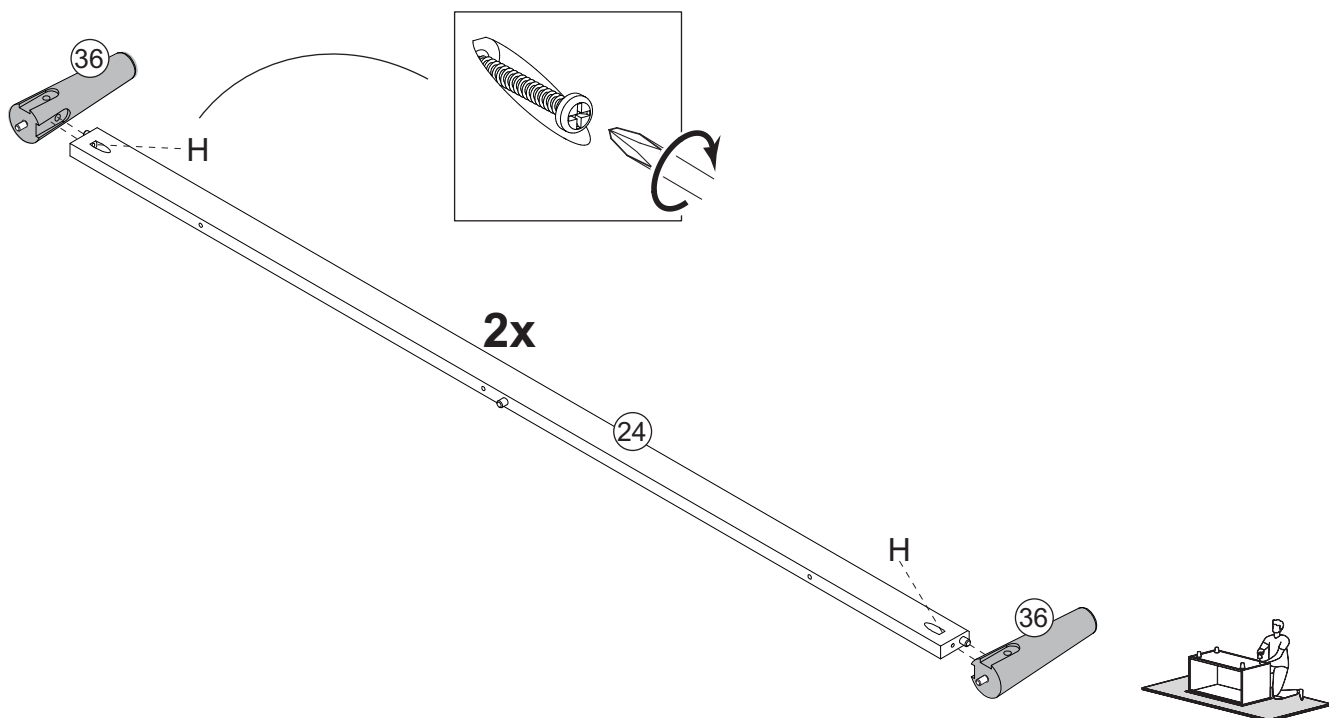

Secure part 24 to parts 36, with screw (H) and phillips head screwdriver.

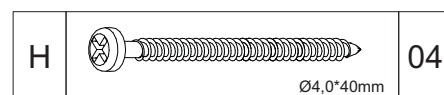

Step 13

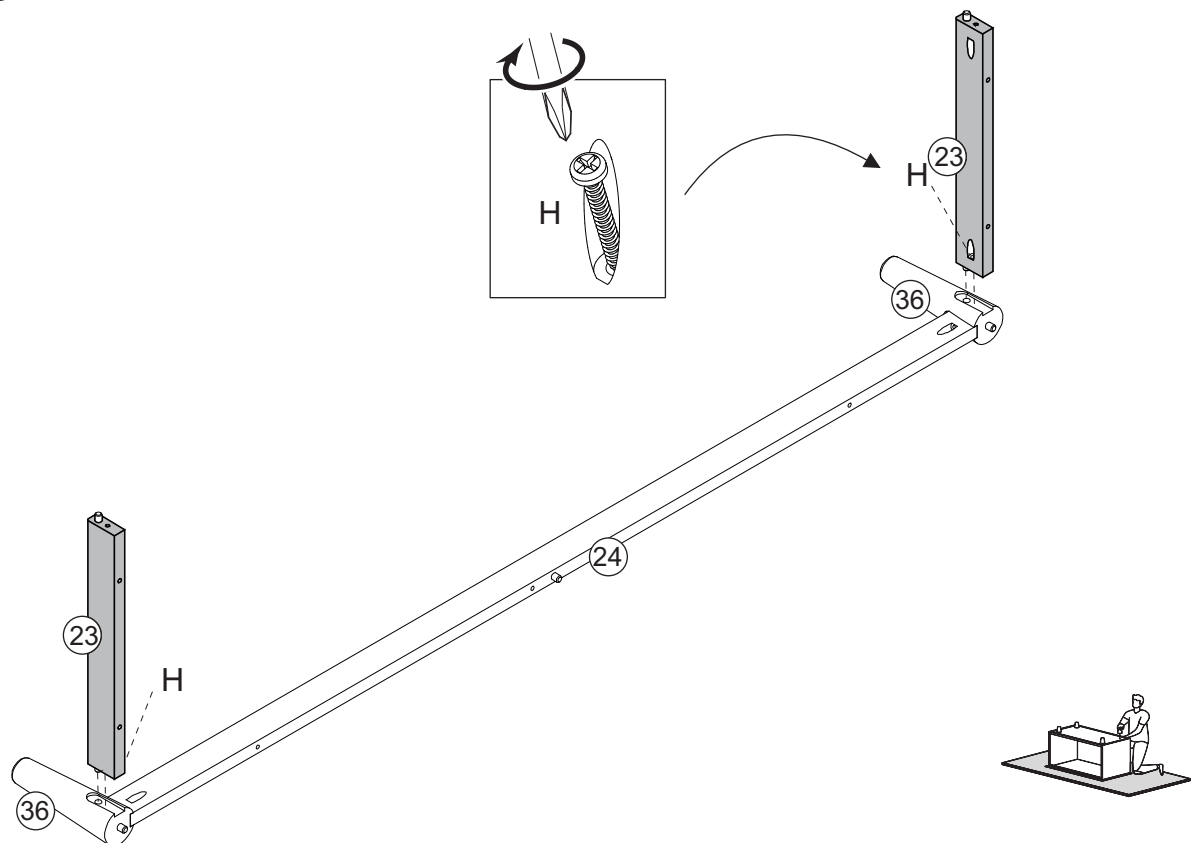

Secure parts 23 to parts 36, with screw (H) and phillips head screwdriver.

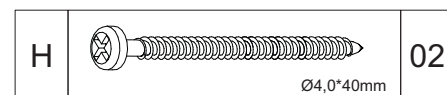

Step 14

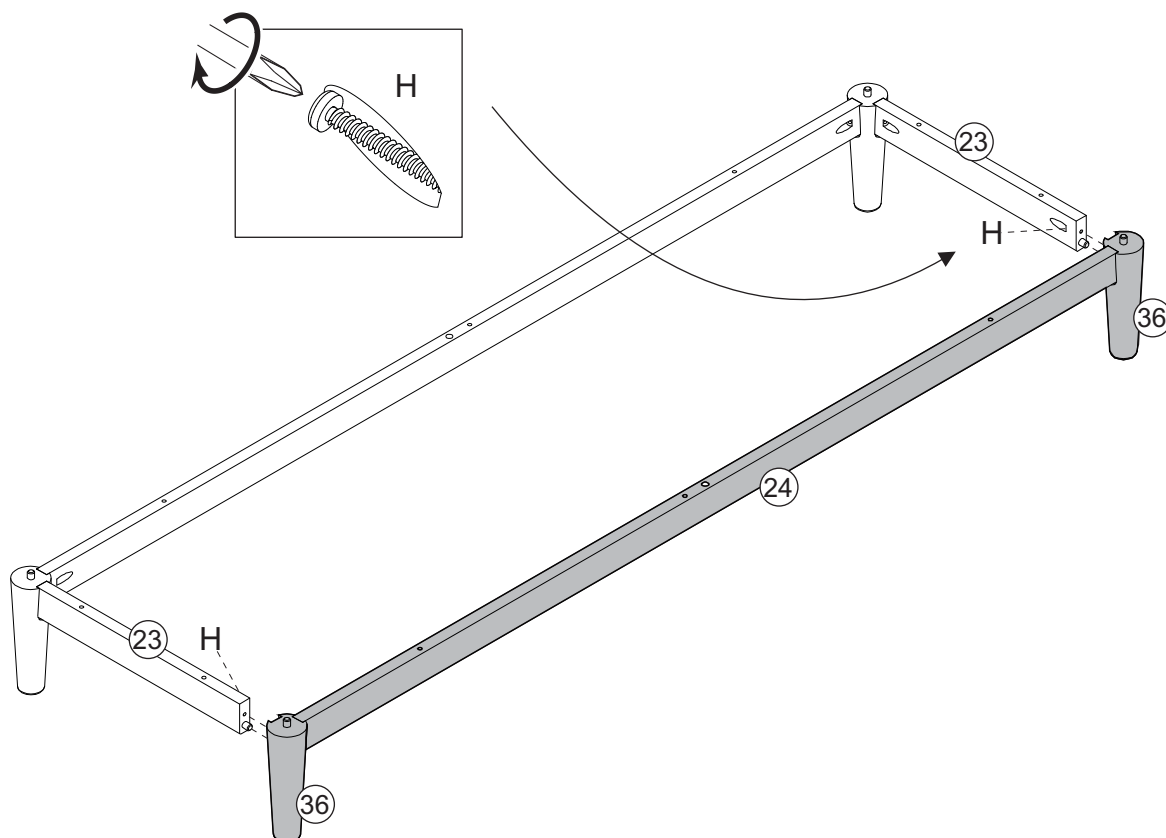

Secure part 23 to parts 36, with screw (H) and phillips head screwdriver.

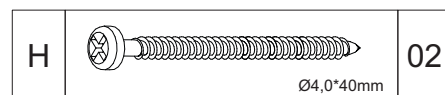

Step 15

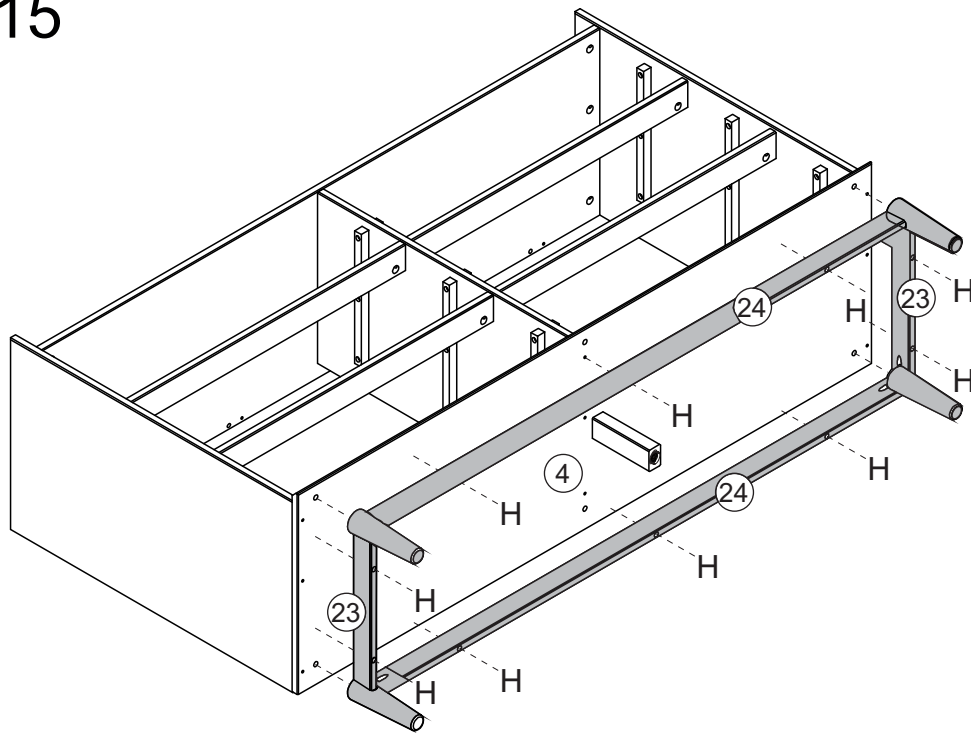

Secure parts 23 and 24 to part 4 with screw (H) and phillips head screwdriver.

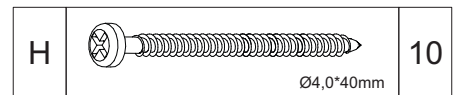

Step 16

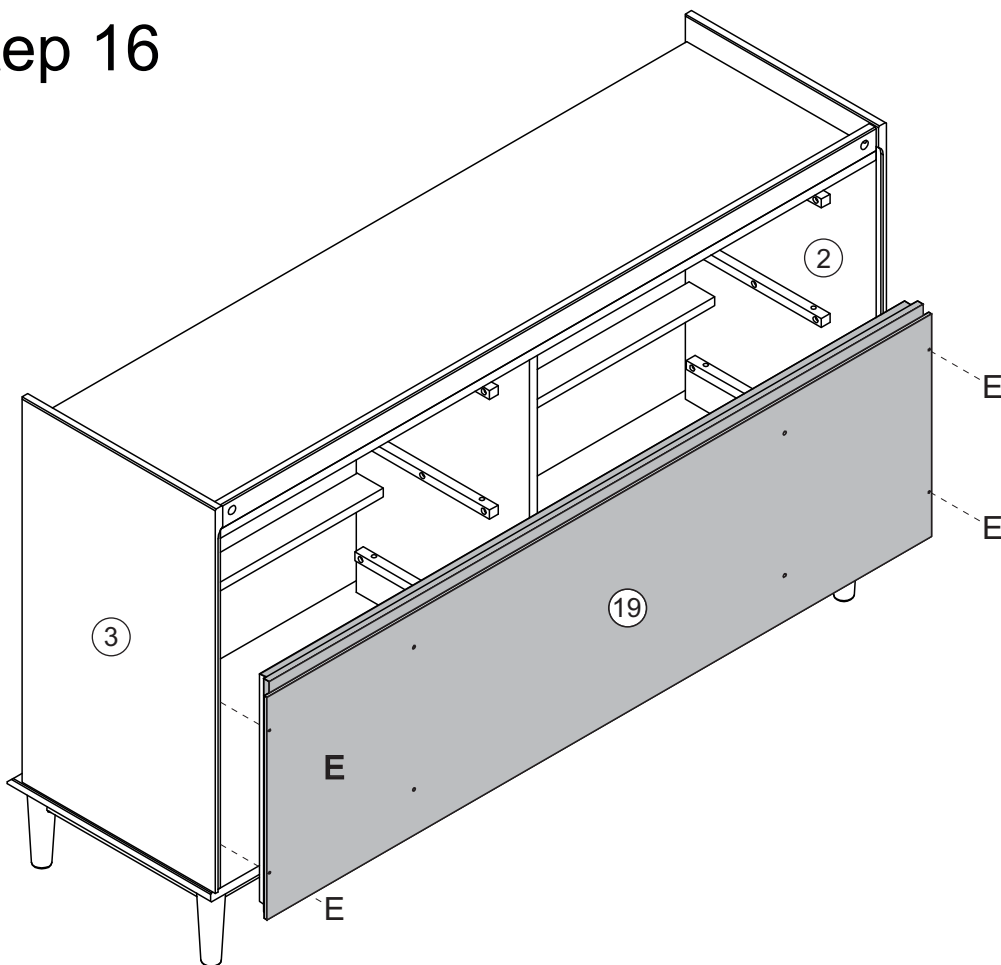

Secure back panel 19 to parts 2 and 3 as shown above with screw (E) and phillips head screwdriver.

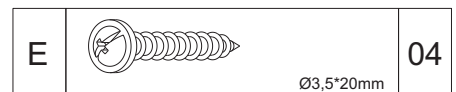

Step 17

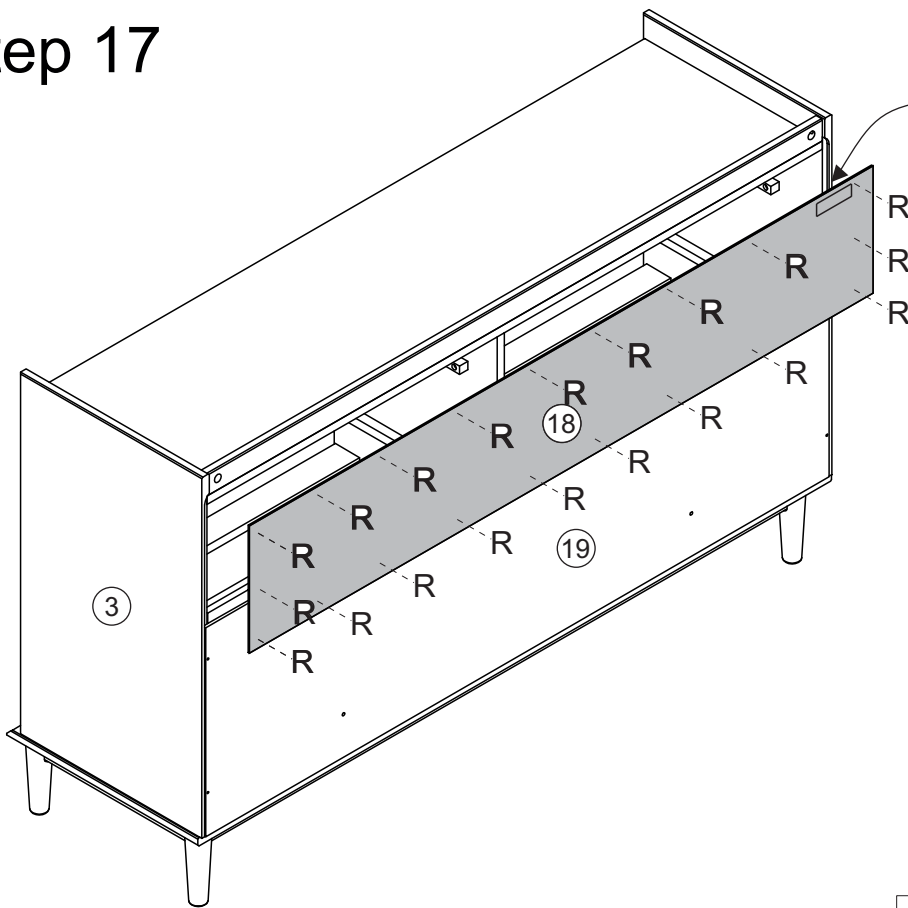

Name and address of the supplier and date of production.

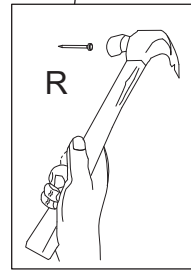

Secure back panel up 18 to parts 1,2,3 and 19 as shown above with nails (R) and hammer.

R		20
Ø8,0*8mm		

Step 18

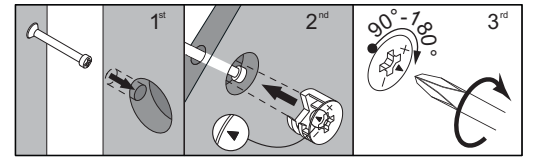

WARNING
 Children have died from furniture tipover. To reduce the risk of furniture tipover:
 • ALWAYS install Anti-tip device provided.
 • NEVER put a TV on this product.
 • NEVER allow children to stand, climb, or hang on any drawers, doors, or shelves.
 • NEVER open more than one drawer at a time.
 • Place heaviest items in the lowest drawers.
 *This is a permanent label. Do not remove!

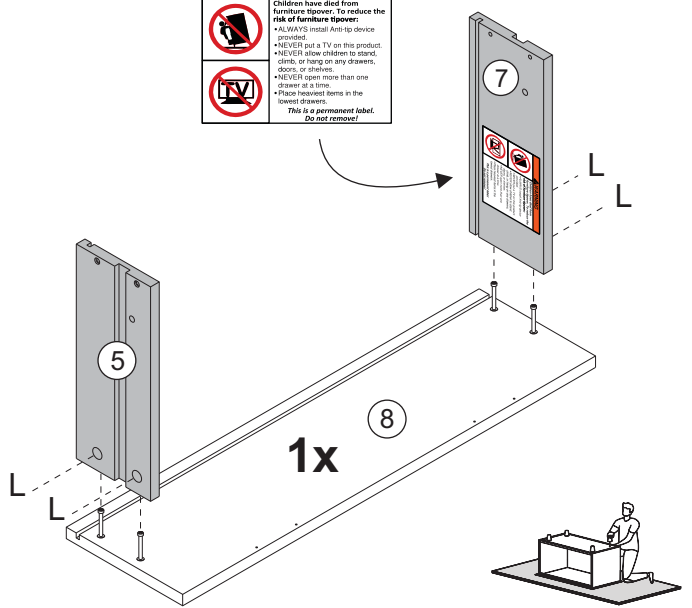
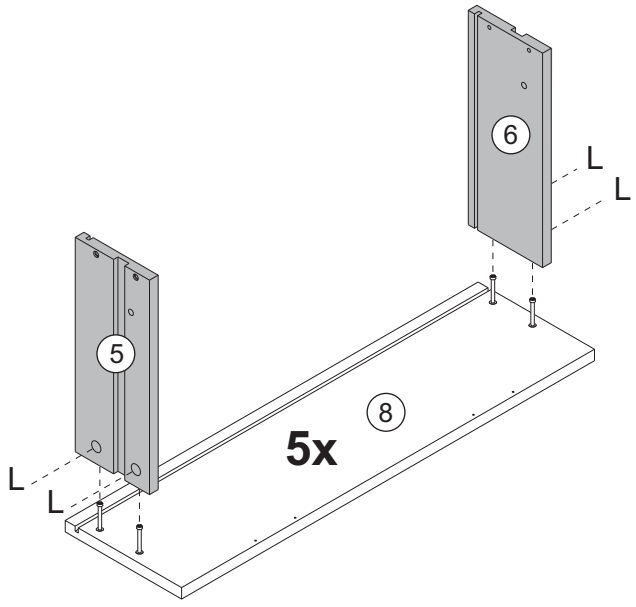

Secure part 5 and 6 to part 8.
 Secure part 5 and 7 to part 8.
 Insert cam locks (L) into parts 5, 6, 7, and tighten with a phillips head screwdriver.

L		24
Ø15*11mm		

Step 19

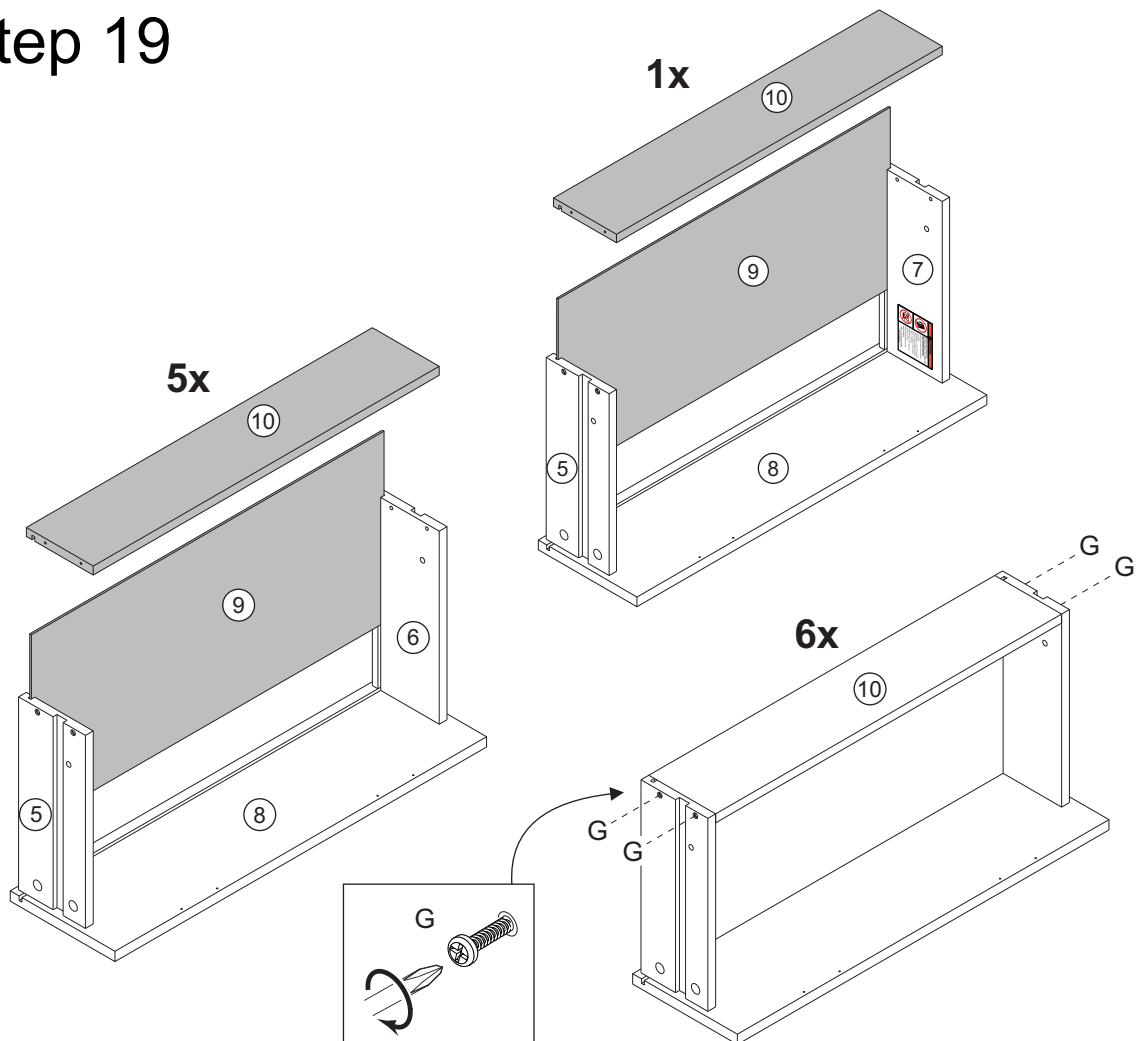

Insert part 9 between the grooves of parts 5, 6 and 7.
Secure part 10 to part 5, 6 and 7 with screw (G) and phillips head screwdriver.

G		24
<small>Ø4,0*30mm</small>		

Step 20

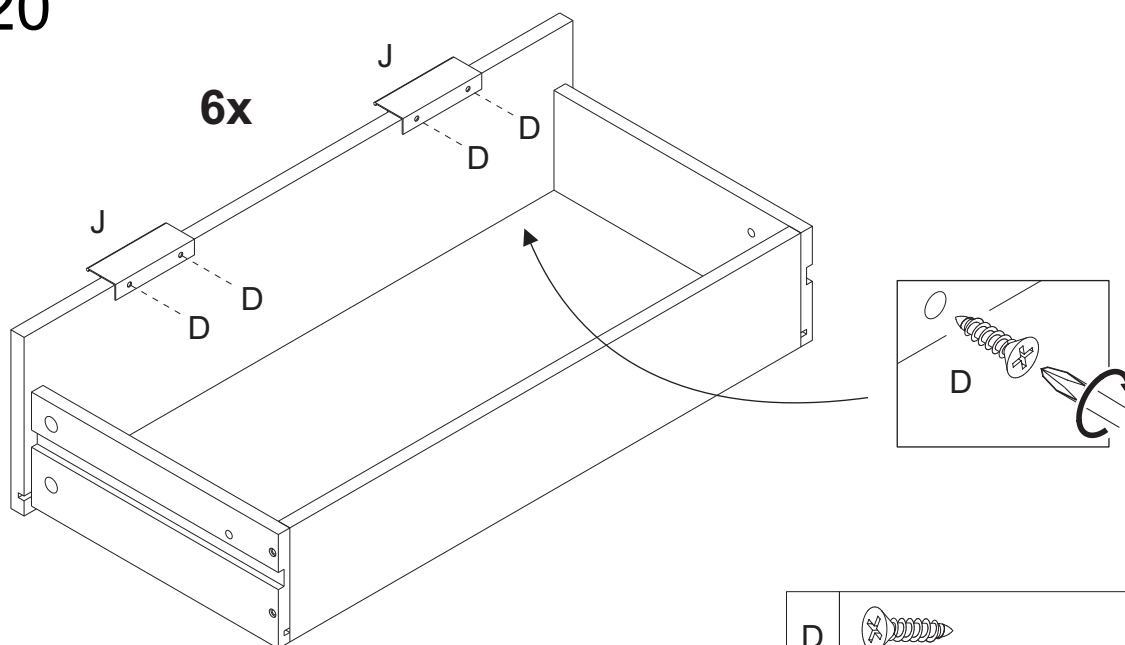

Secure handle (J) with screw (D) and phillips head screwdriver, in the pre-drilled holes on the drawer front.

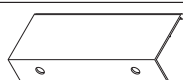
D		24
<small>Ø3,0*12mm</small>		
J		12

Step 21

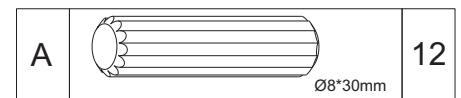
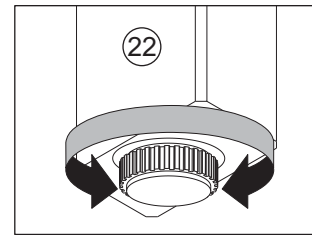
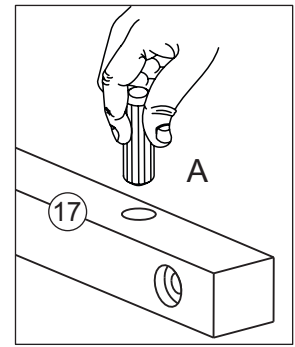
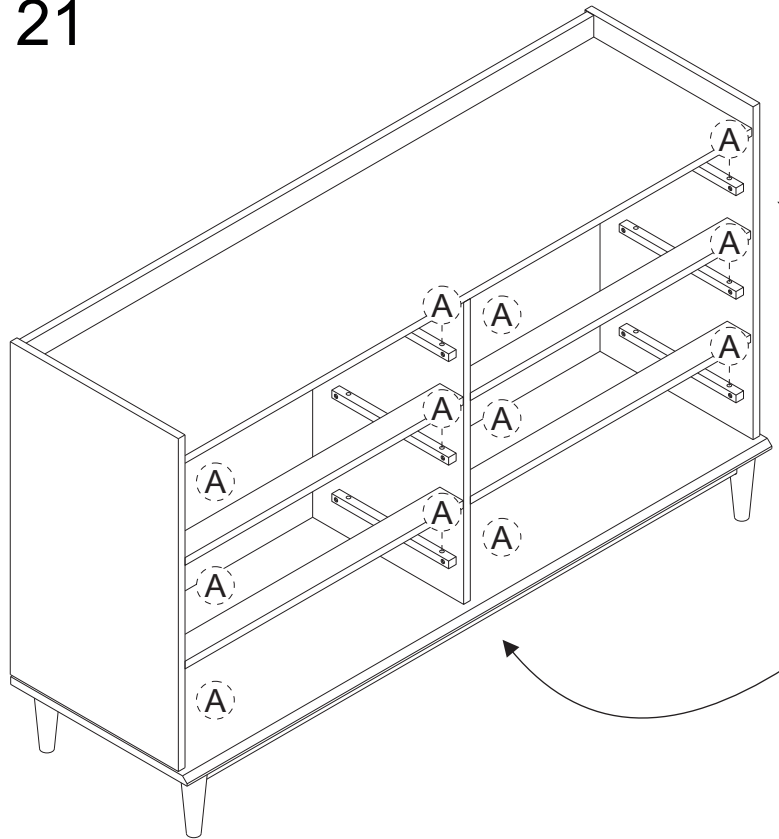

Insert wood dowel (A) into part 17 to be the stop of the drawer.

Step 22

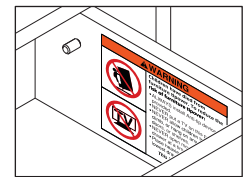
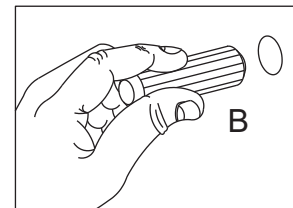
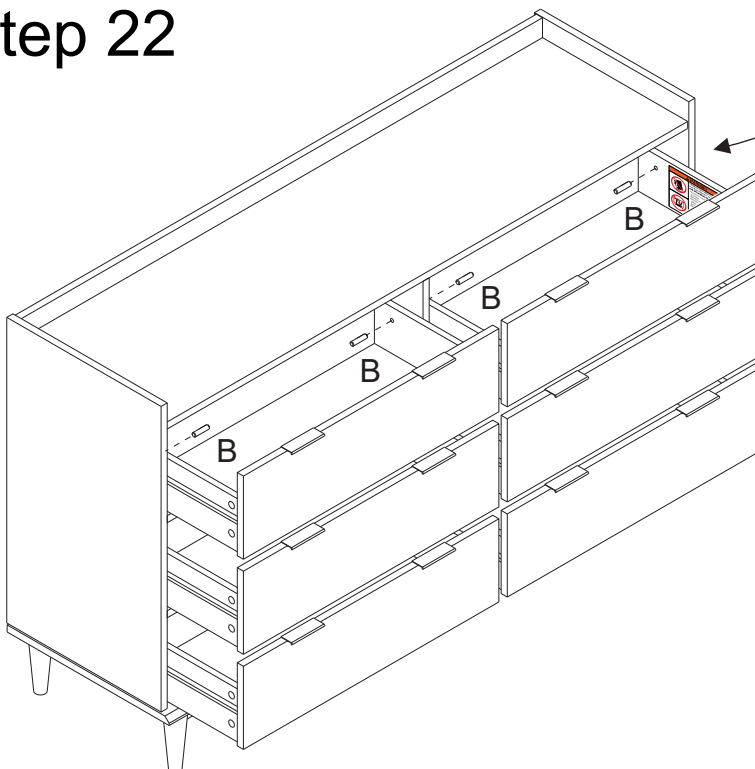

The assembled drawer with this warning must be placed on top of the unit.

Insert wood dowel (B) on the inside of all drawers, with the drawer inside the unit, after having passed the wood dowel that is in the drawer slide.

The dowel is not flush with the panel, it is a little inside the drawer to help when you need to remove the lock dowel to remove the drawer.

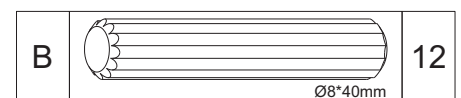

Step 23

WARNING

Serious or fatal injuries can occur from furniture tipping over. To prevent the furniture from tipping over we recommend that it is permanently fixed to the wall.

Wall anchor and hardware are included with this product. Please make sure hardware is suitable for your walls before installing, as different wall materials may require different types of anchors.

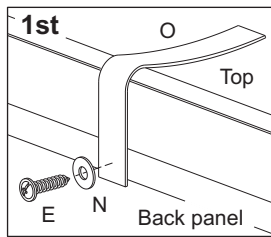

1st

Attach part (O) with Screw (E) and Washer (N), in the frame of top panel unit.

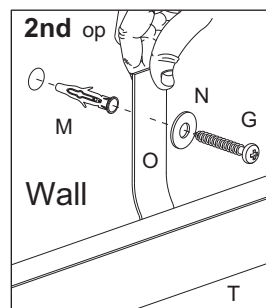
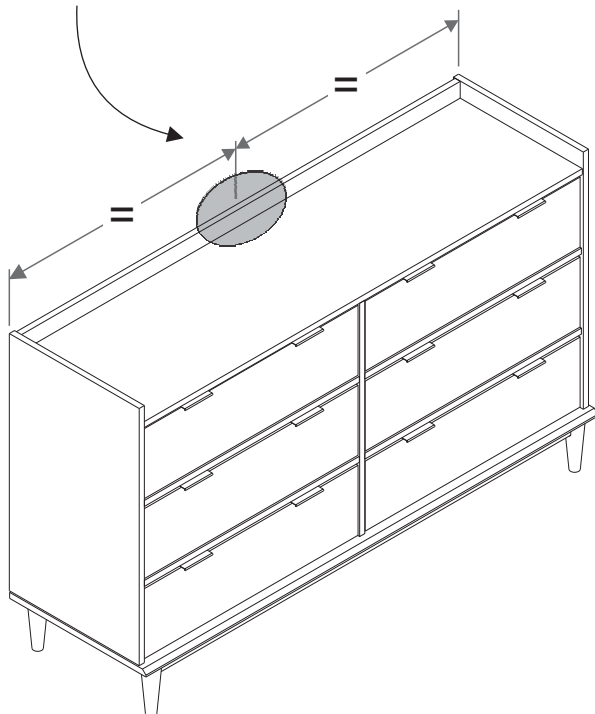
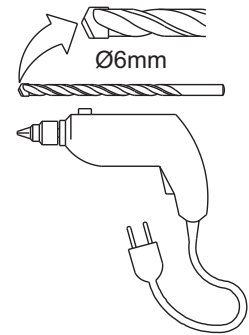



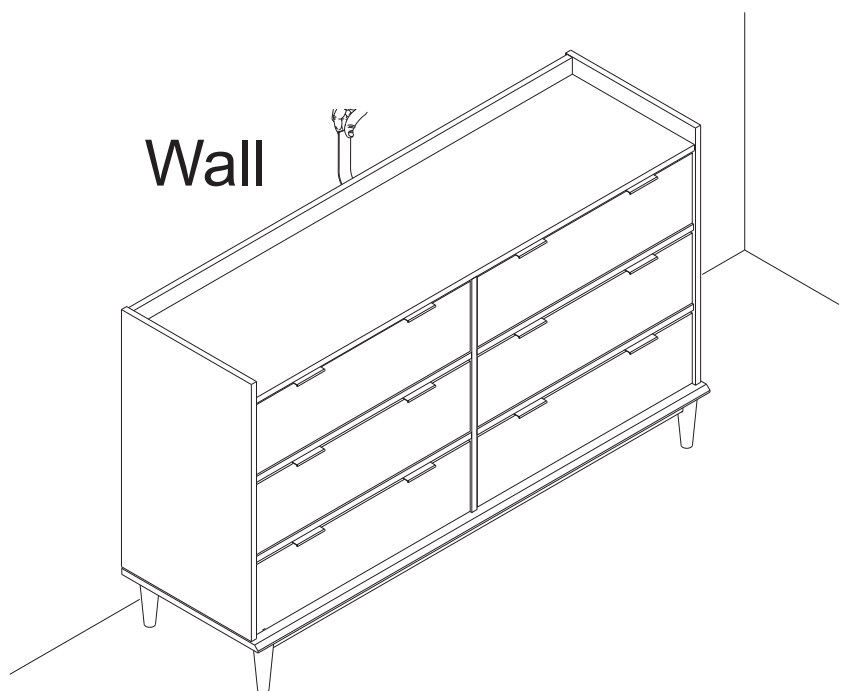

2nd

With drilling machine make one hole in the wall, Insert part (M) in the hole. Secure part (O) with Screw (G), and Washer (N), in the wall.

Wall

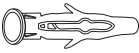

E		01
	Ø3,5*20mm	
G		01
	Ø4,0*30mm	
M		01
N		02
O		01

Name and address information for the manufacturer responsible for the anti-tip hardware and date of production can be found on the label on the back of the furniture.

Step 24

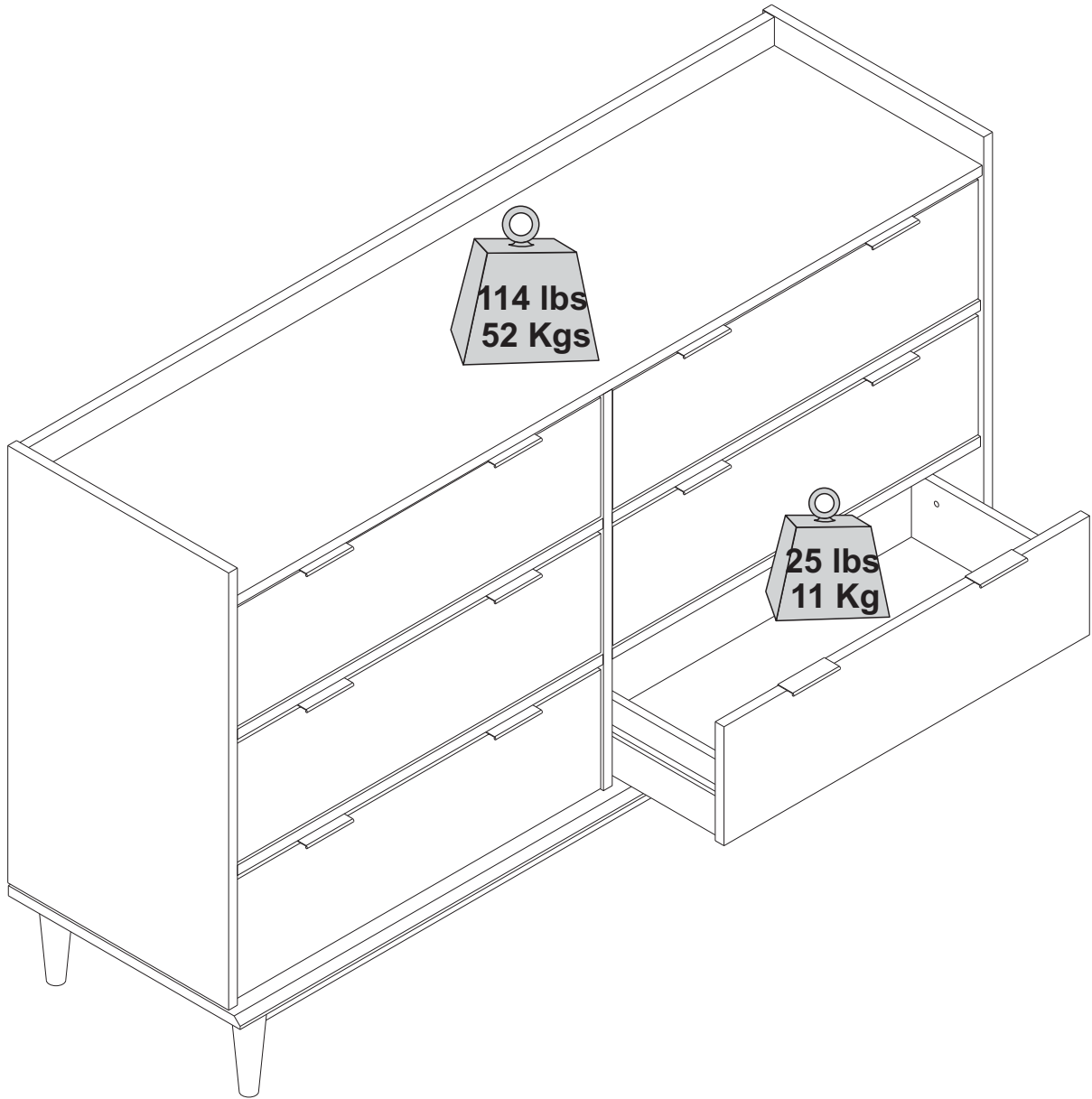

Assembly Complete!

