

WALKER EDISON

TM

30" Atticus 5 Drawer Solid Wood Mid-Century Modern Chest

SKU# BR5DATTDR-T

LOT: AAYYWW-XXX

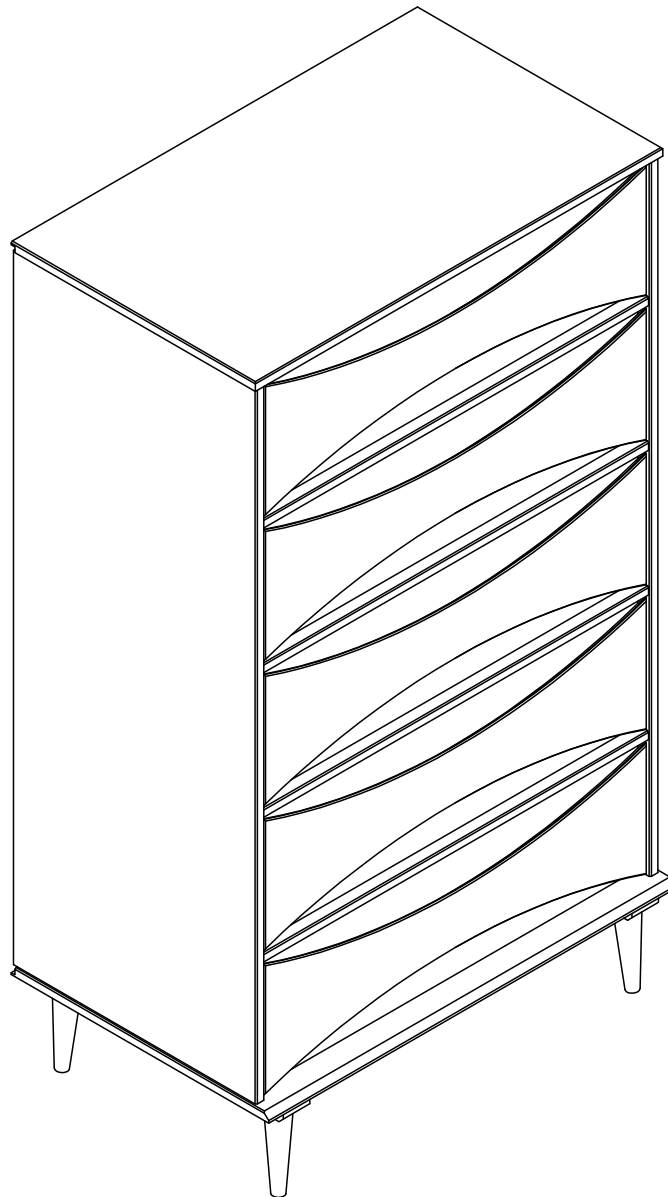

For Residential Use Only

Please visit our website for the most current instructions, assembly tips, report damage, or request parts. www.walker-edison.com

WE Time to get started

Set up a clean and soft workplace to avoid damage during assembly. You can use the box and internal protections as cover. It also helps to double-check if you've got all the pieces and parts before diving in assembly.

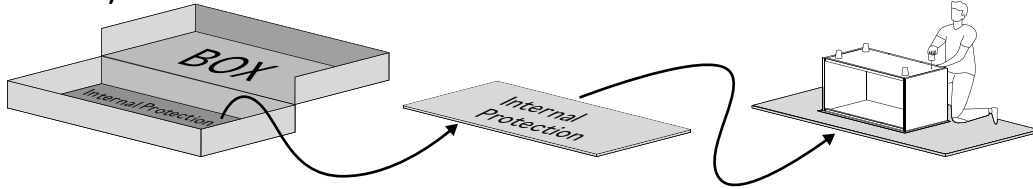

Estimated time for assembly

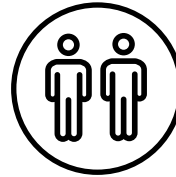

2 People Build

People recommended for assembly

Make it a team effort!
Grab a friend for quicker, easier assembly.

Tools Needed

Grab a Phillips head screwdriver to conquer this assembly. We will also need a hammer to help.

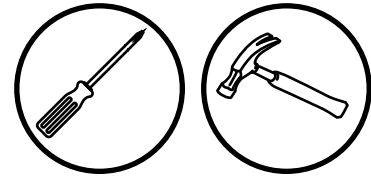

Use power tools with caution

This furniture is made of Solid Wood and Composite Wood, soft materials. If you choose to use power tools, set it to the slower setting. Be careful! Power tools can cause cracking or damage to the furniture, they can also damage the hardware if misused.

Power tool damages are not covered by the Walker Edison warranty.

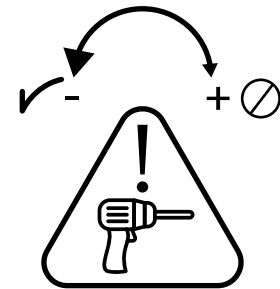

Slide care

Your furniture has highly durable wooden sliders. From time to time we recommend applying paraffin or standard candle wax to improve gliding of the sliders.

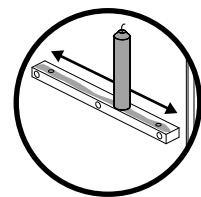

Scan to get assembly tips and help!



Parts List

Part Number	Description	Quantity
1	Top Panel	1
2	Left Side Panel	1
3	Right Side Panel	1
4	Base	1
5	Front Rail	4
6	Large Wood Slider	10
7	Foot	2
8	Back Panel	2
9	Drawer Front	5



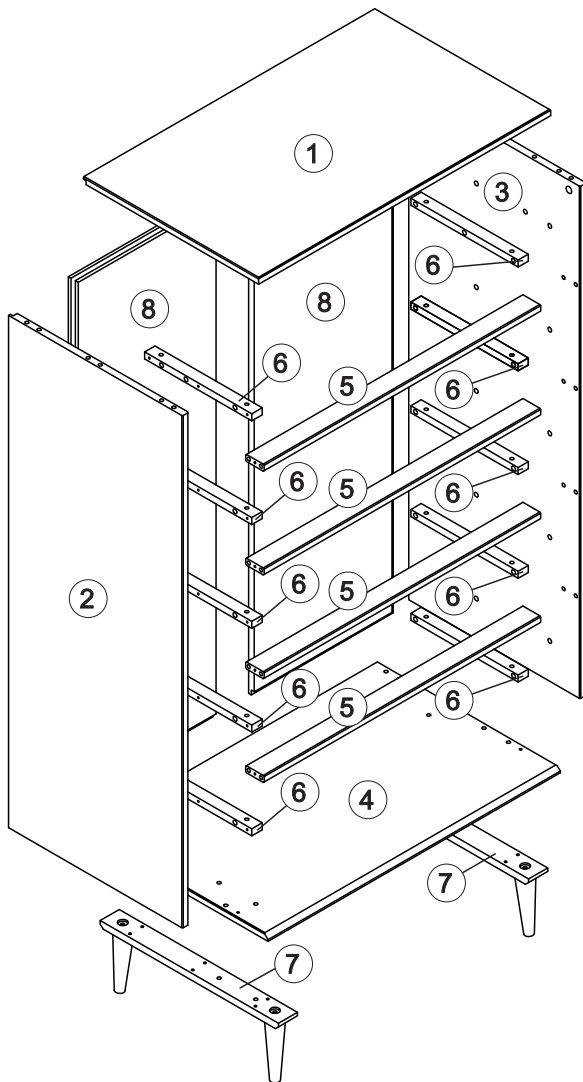



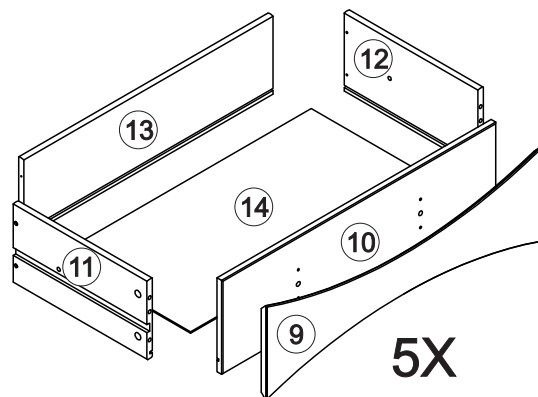
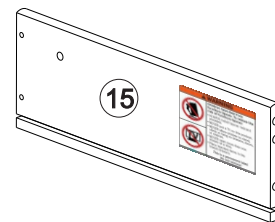

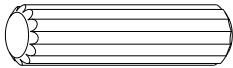
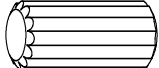

Part Number	Description	Quantity
10	Drawer Front	5
11	Left Drawer Side	5
12	Right Drawer Side	4
13	Drawer Back	5
14	Drawer Bottom	5
15	Right Drawer Side with Warnig	1

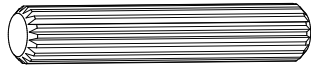
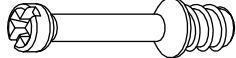

The side drawer with WARNING LABEL, should be mounted in highest drawer.



WE Hardware List

Part	Size	Name	Quantity
A	 Ø8*30mm	Wooden dowel	54
B	 Ø10*20mm	Wooden dowel	40
C	 Ø4,0*25mm	Screw	62
D	 Ø3,5*30mm	Screw	28
E	 Ø4,0*40mm	Screw	06
F	 Ø10*10mm	Nail	36
I	 Ø8*40mm	Wooden dowel	10
J	 ø15*30mm	Cam bolt	26
K	 ø15*10mm	Cam lock	26
L		Wall anchor	01
M		Washer	02
N	 Ø6*35mm		01
O	 Ø4*16mm	Screw	01
P	 Ø4,0*40mm	Screw	01

The hardware quantities listed above are required for proper assembly.

Extra hardware pieces may be included.

Step 1

Let's start! Insert Wooden dowels (B) into Large wood sliders (6) and Drawer Front (9).

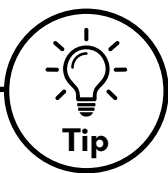
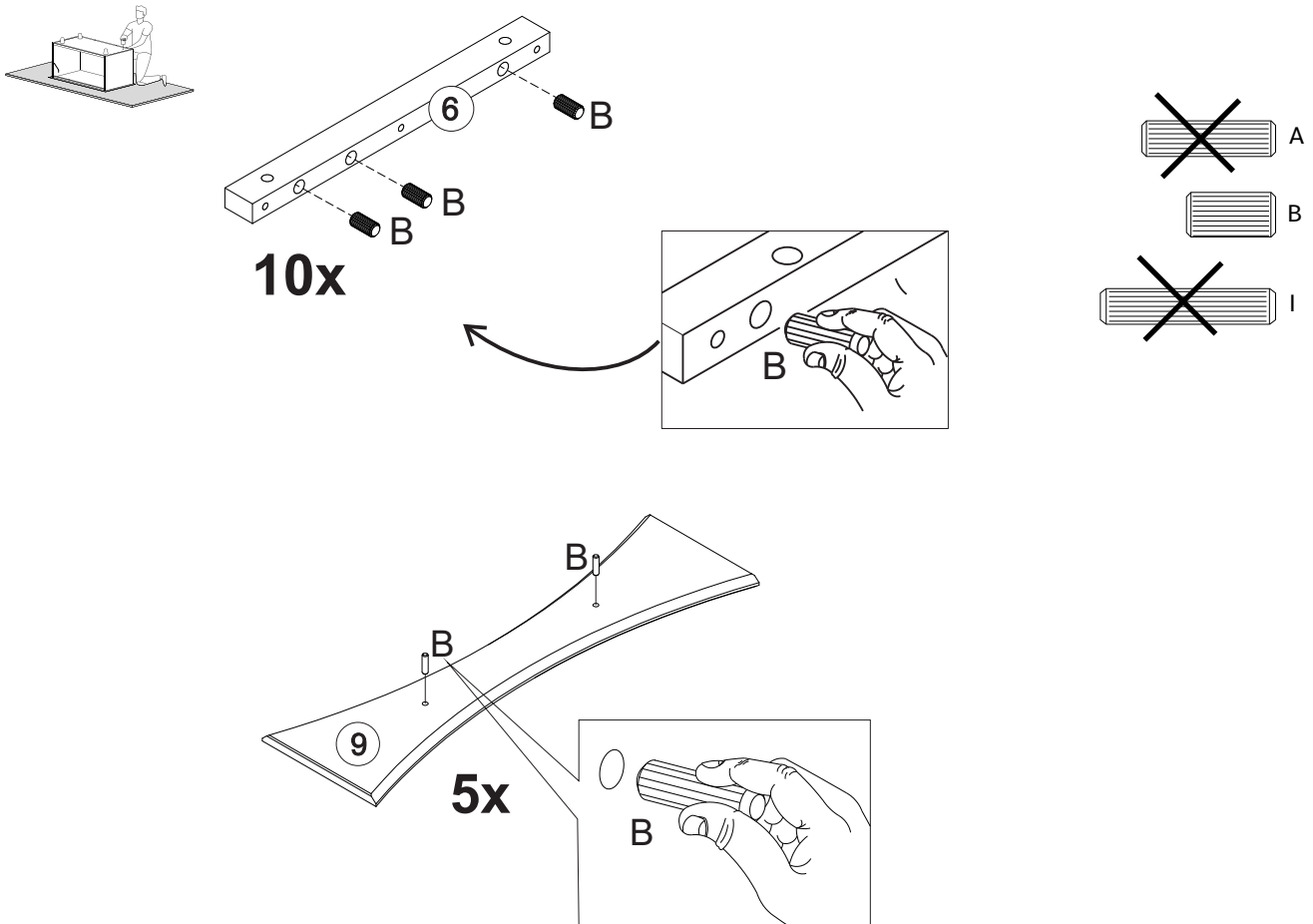

Wood Dowels

Dowels are essential in furniture assembly to create strong, precise connections. They ensure structural integrity, prevent shifting, and simplify alignment, resulting in sturdier, longer-lasting furniture.

Follow these steps:

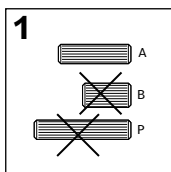

1: Select the appropriate size dowel according with step.

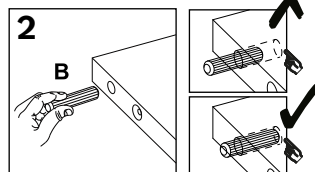

2: Insert into drilled hole and press firmly to ensure placement is set.

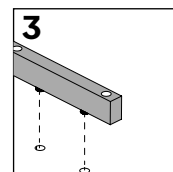

3: Align the dowel with corresponding piece and press together until secure.

Step 2

Also insert Wooden dowel (A) into parts Left Side Panel (2), Right Side Panel (3), Front Rail (5), Foot (7), Left Drawer Side (11), Right Drawer Side (12) and Right Drawer Side with warning (15).

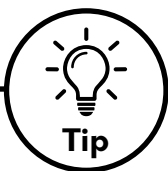
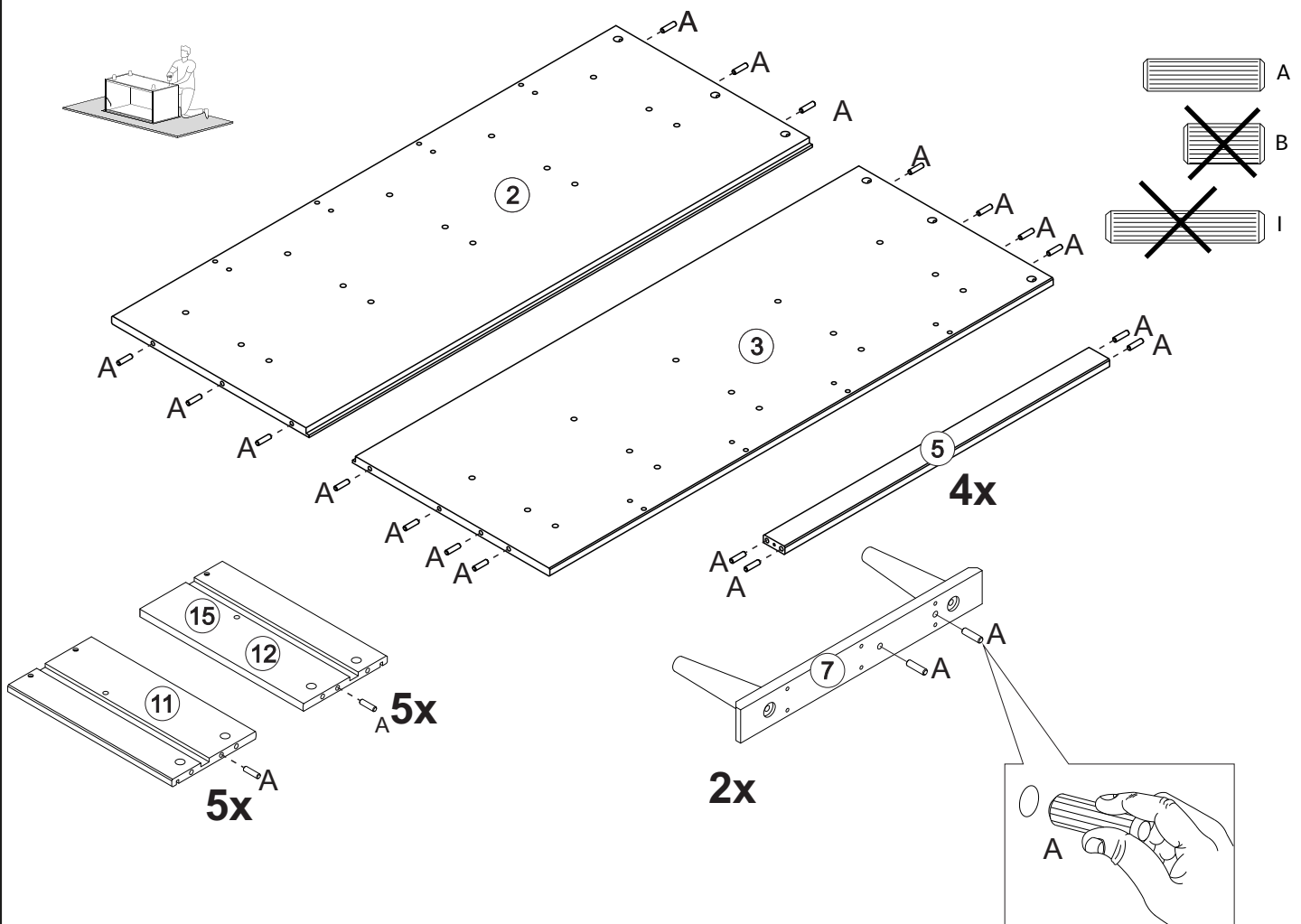

Tip

To keep your product looking its best and scratch-free, try assembling it on a soft surface like carpet or a blanket. This helps prevent any accidental scratches and keeps your furniture in top shape!

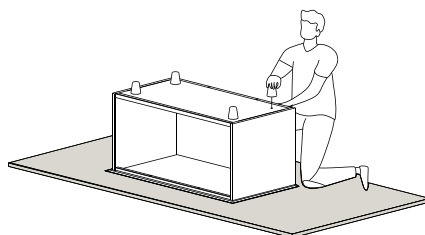

Step 3

Attach Cam bolts (J) into Top panel (01) and Drawer front (10) using a Philips head screwdriver.

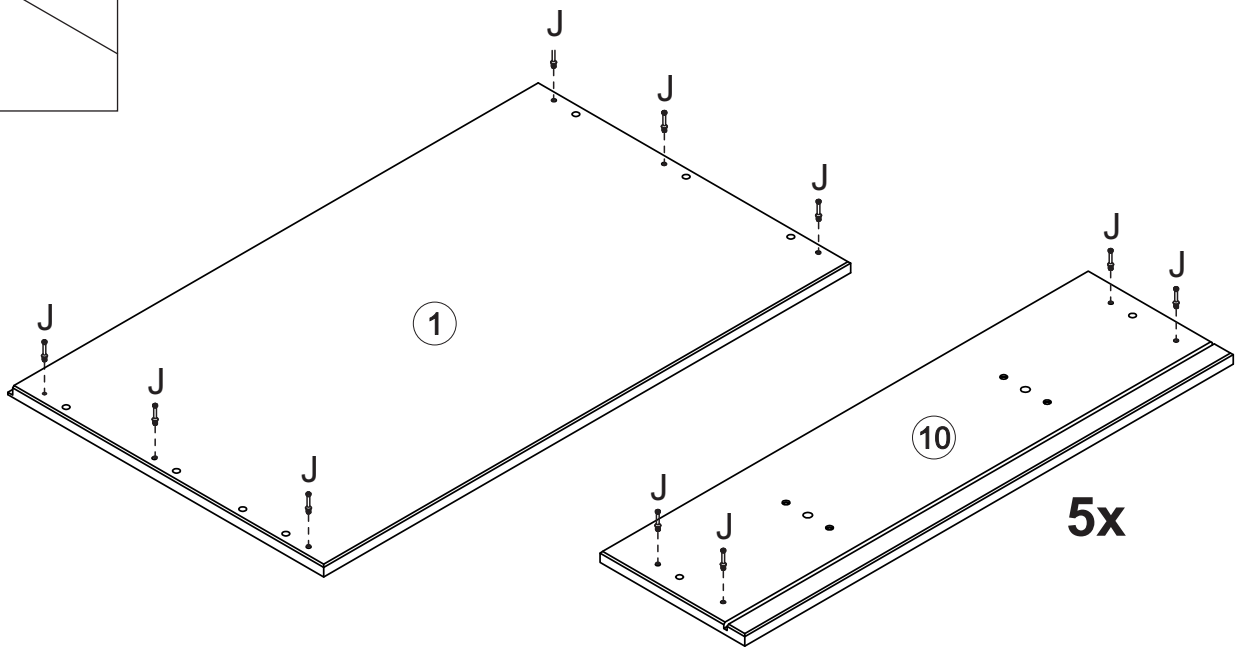
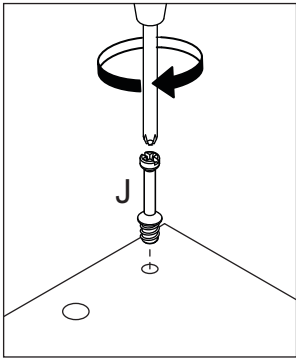
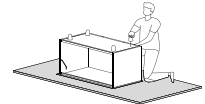

Step 4

Secure Large wood sliders (6) to Left side panel (2) and Right side panel (3) using Screw (C) and a phillips head screwdriver.

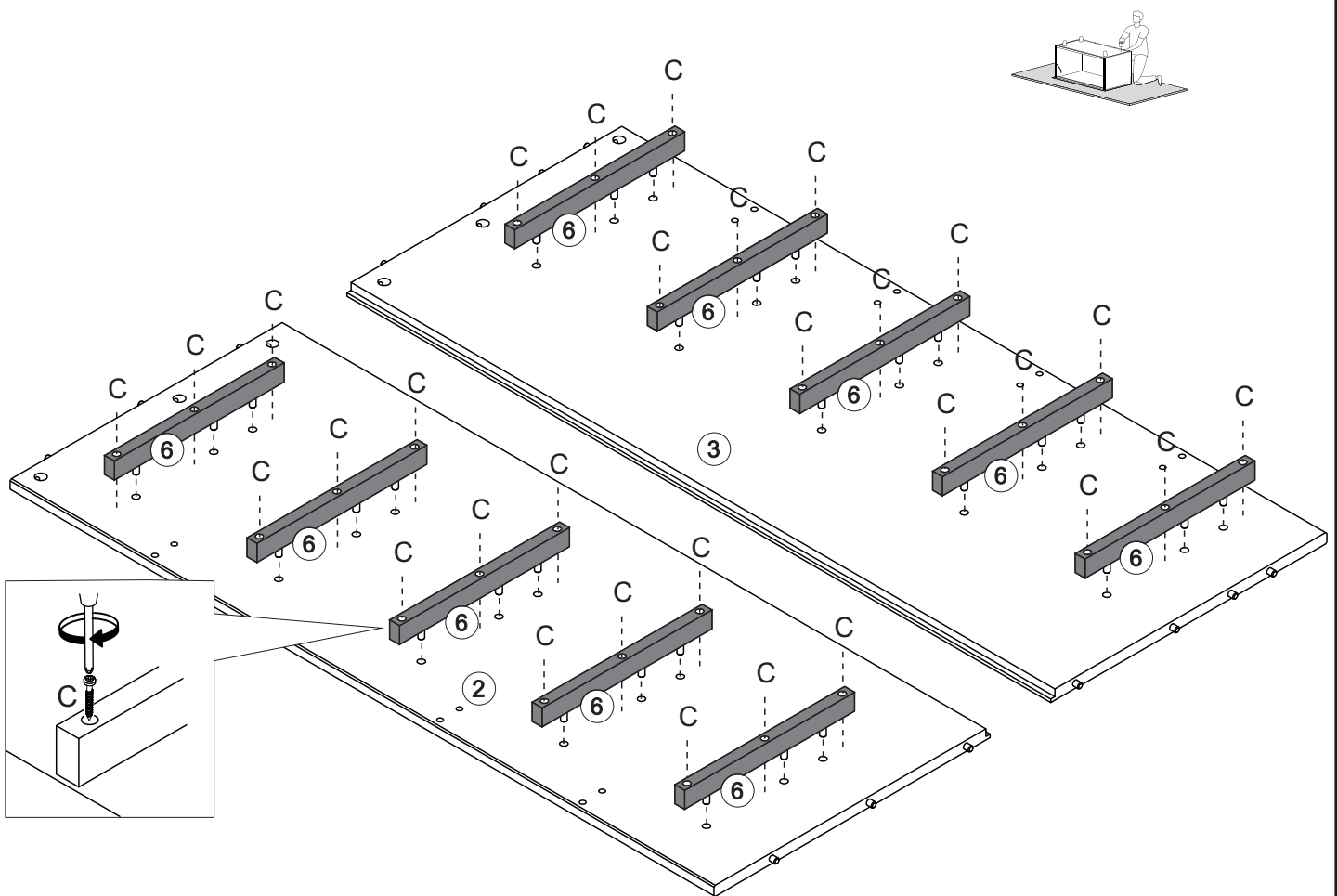

Step 5

Join Front rails (05) to Left side panel (2) and Right side panel (03) using Screws (D) and a philips head screwdriver.

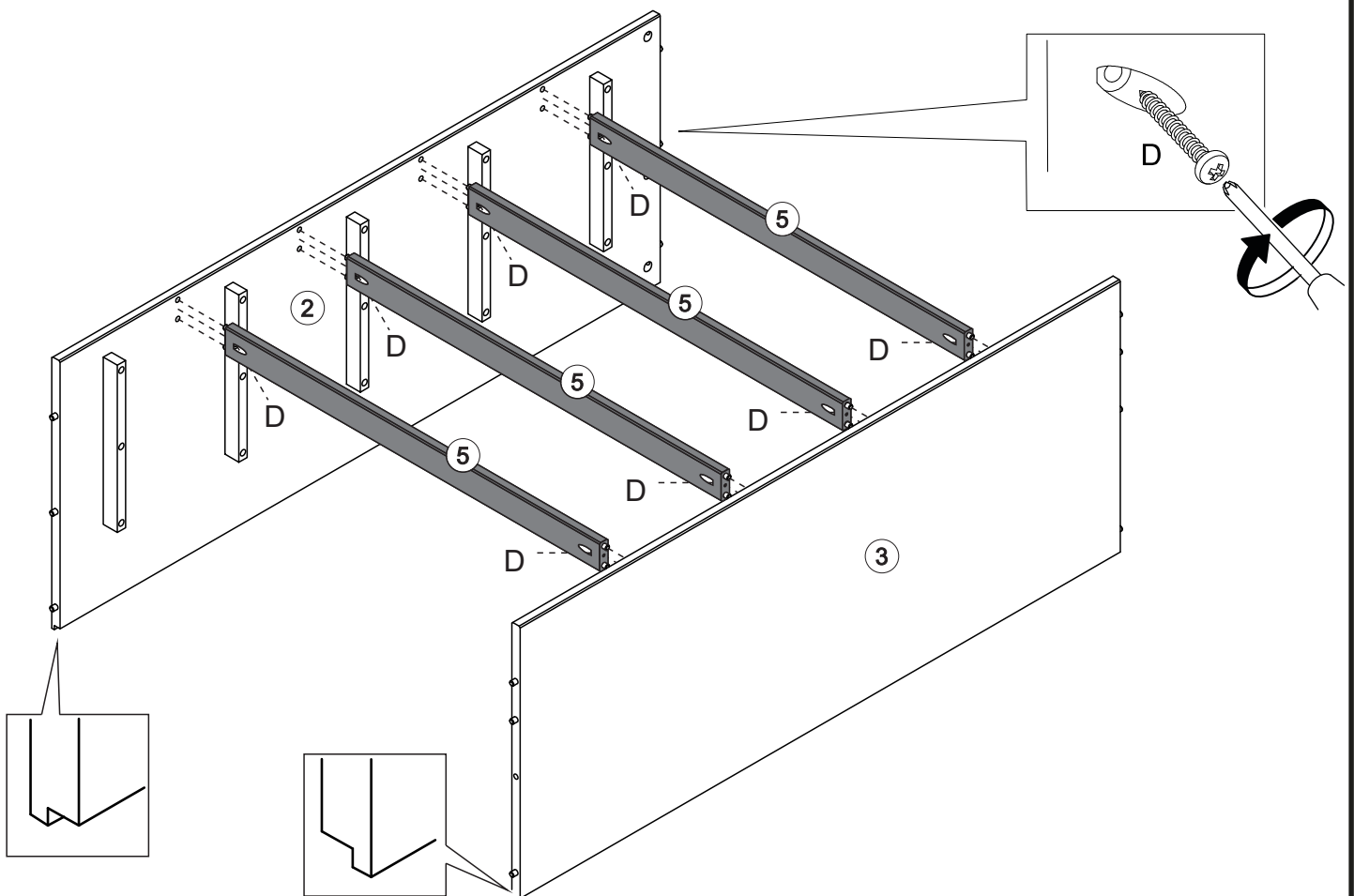
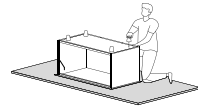

Step 6

Attach Base (04) to Left side Panel (02) and Right side panel (03) using screw (E) and a philips head screwdriver.

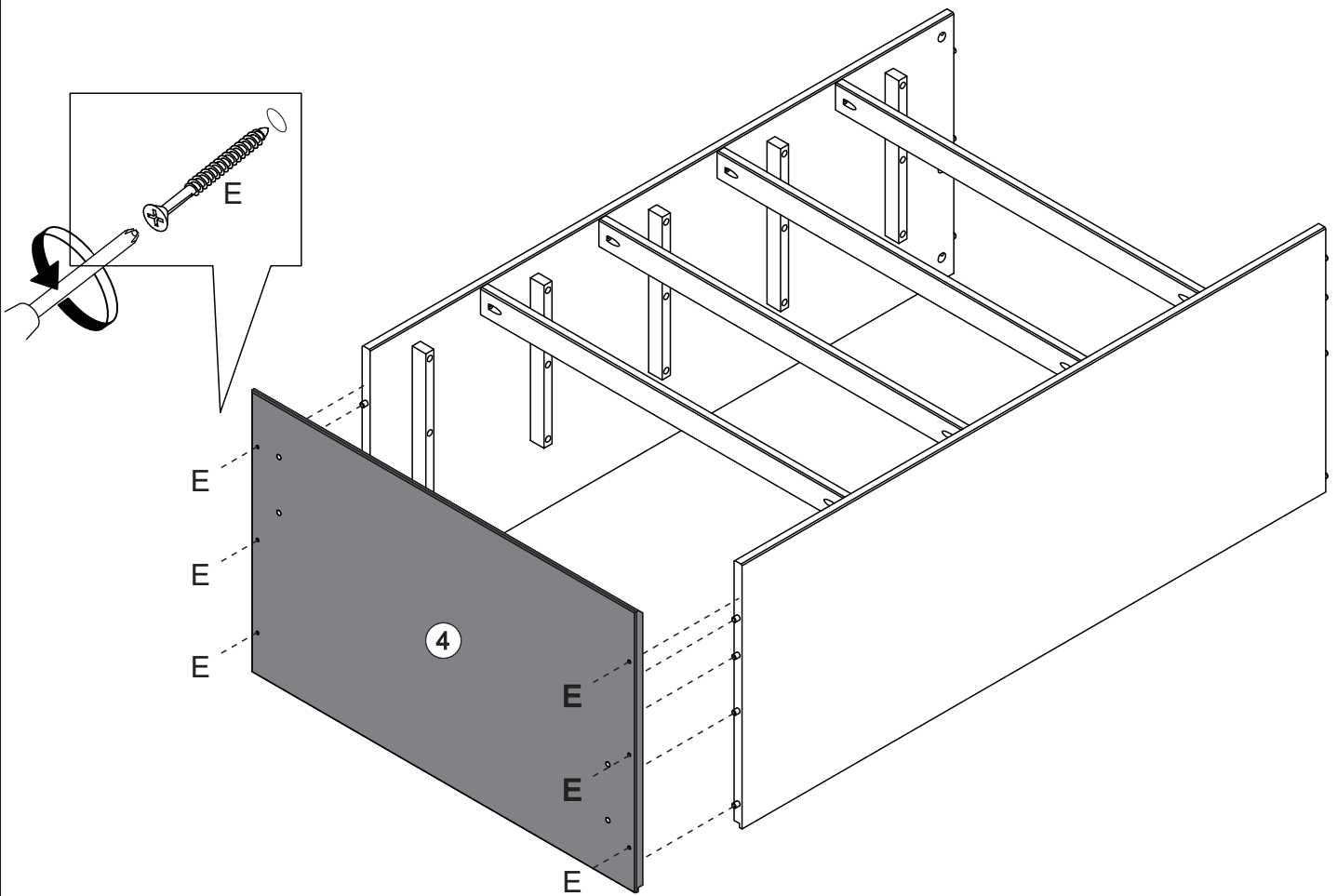
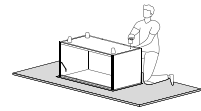

Step 7

Secure Foot (07) to Base (04) using Screw (C) and a philips head screwdriver.

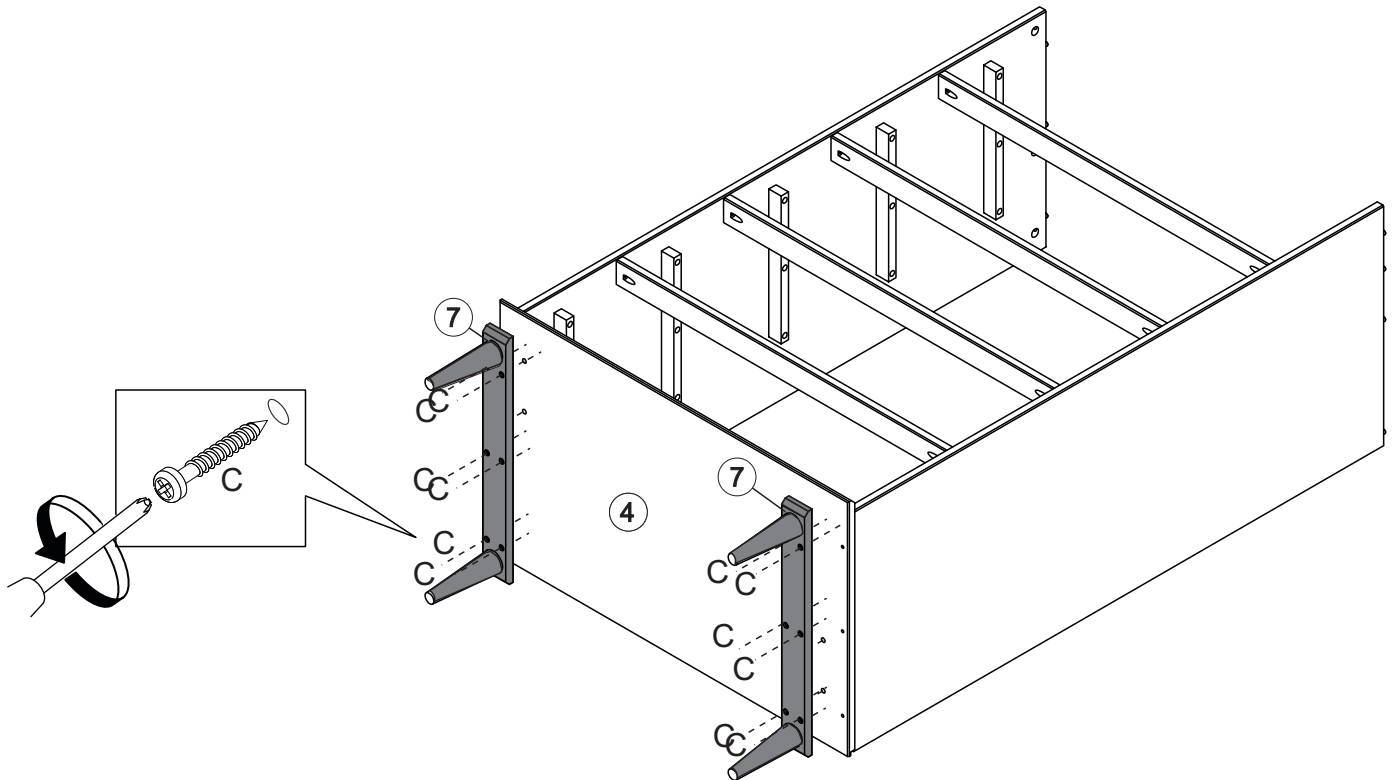
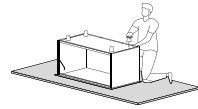

Step 8

Attach Top panel (01) to Left side panel (02) and Right side panel (03) using Cam lock (K) and a phillips head screwdriver.

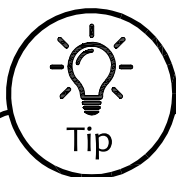
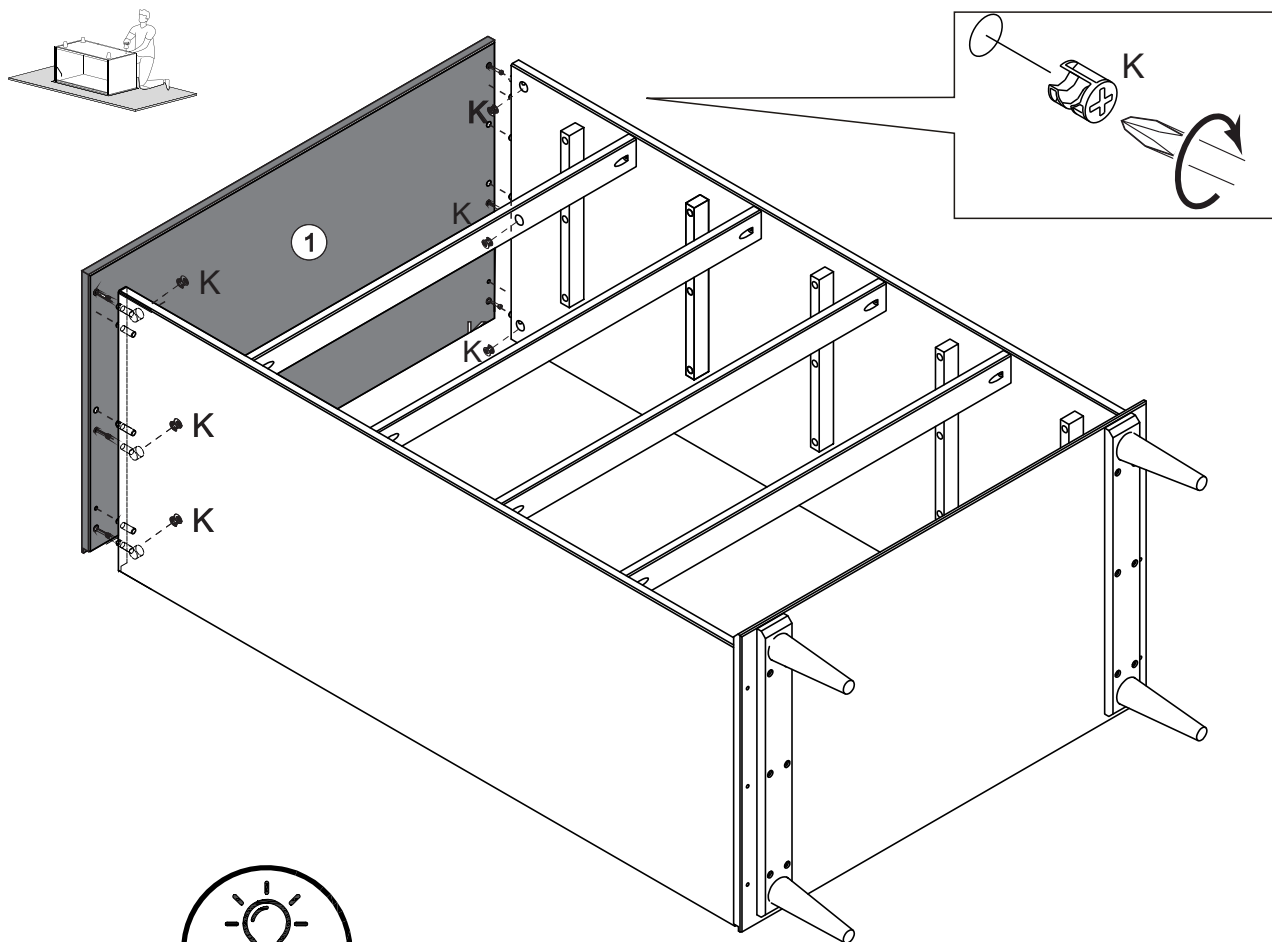

Cam Locks

Cam Locks help securely join two pieces together.
Follow these easy steps.

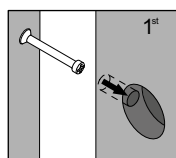

1: Insert Cam Bolt into bolt holes on the flat side. Don't over tighten!

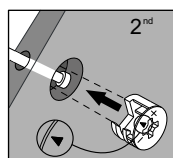

2: Assemble both parts together. The cam bolts goes in the drilled holes that have a circular hole on the side, you should be able to see the cam bolt through it. After fitting parts together insert the cam lock on the side holes.

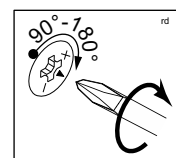

3: On the back of the Cam Lock will be a "C" shape. Insert the Cam Lock so the opening of the "C" fits over the Cam Bolt. Tighten with the screwdriver.

Step 9

Insert Wooden dowels (A) into Large wood sliders (06).

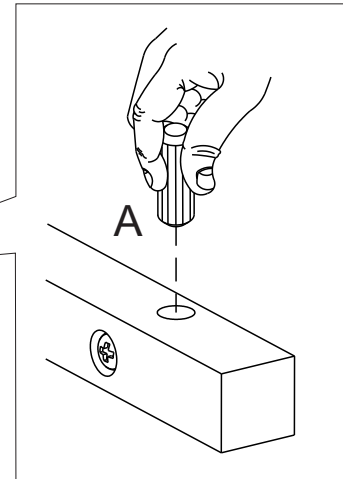
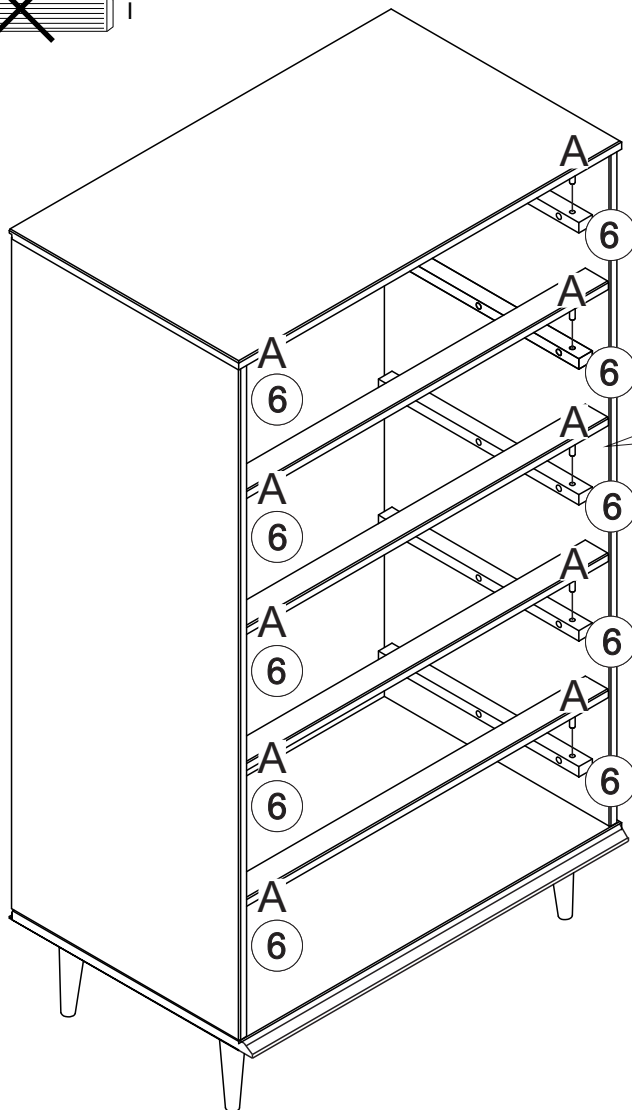
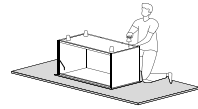
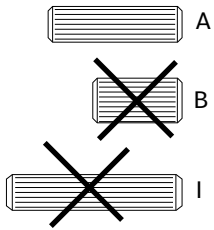

Step 10

Secure Back panel (08) using Nails (F) and a hammer.



Name and address of the supplier and date of production.

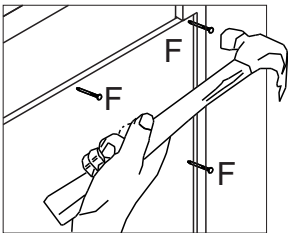
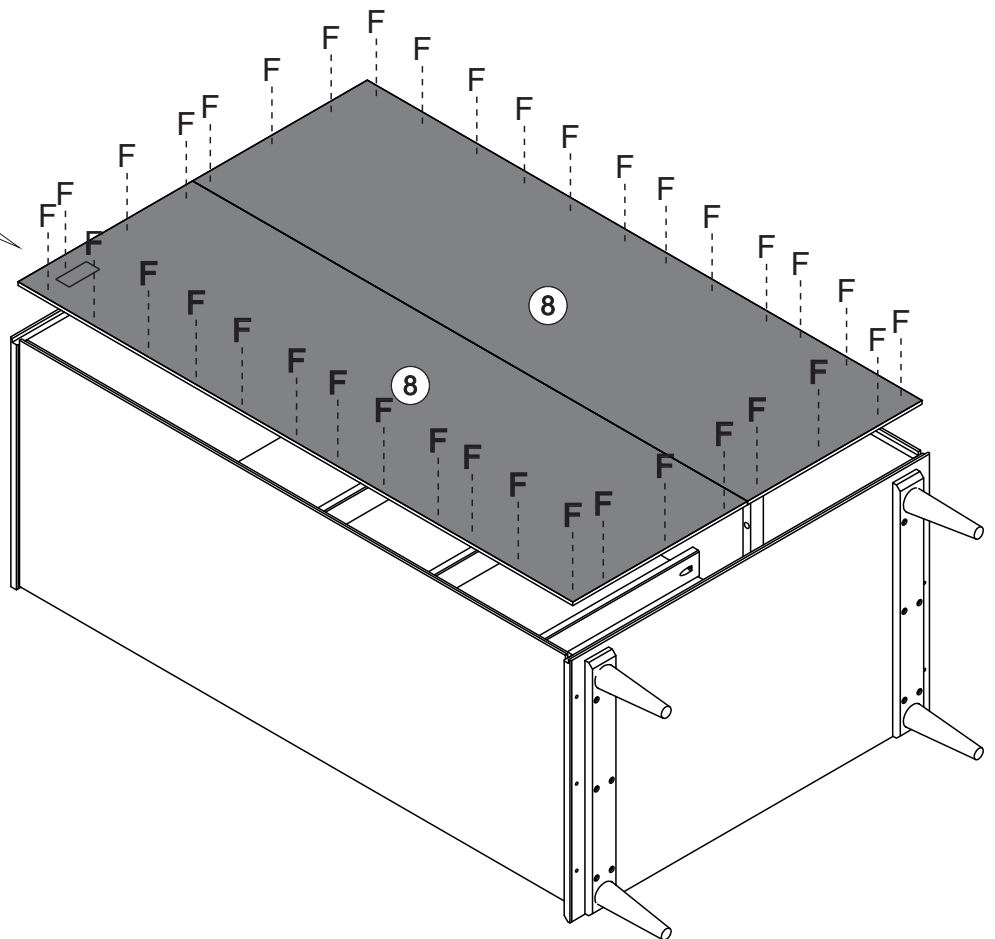

Step 11

Assemble the drawer front by joining Drawer front (09) to Drawer front (10), using Screws (C) and a philips head screwdriver.

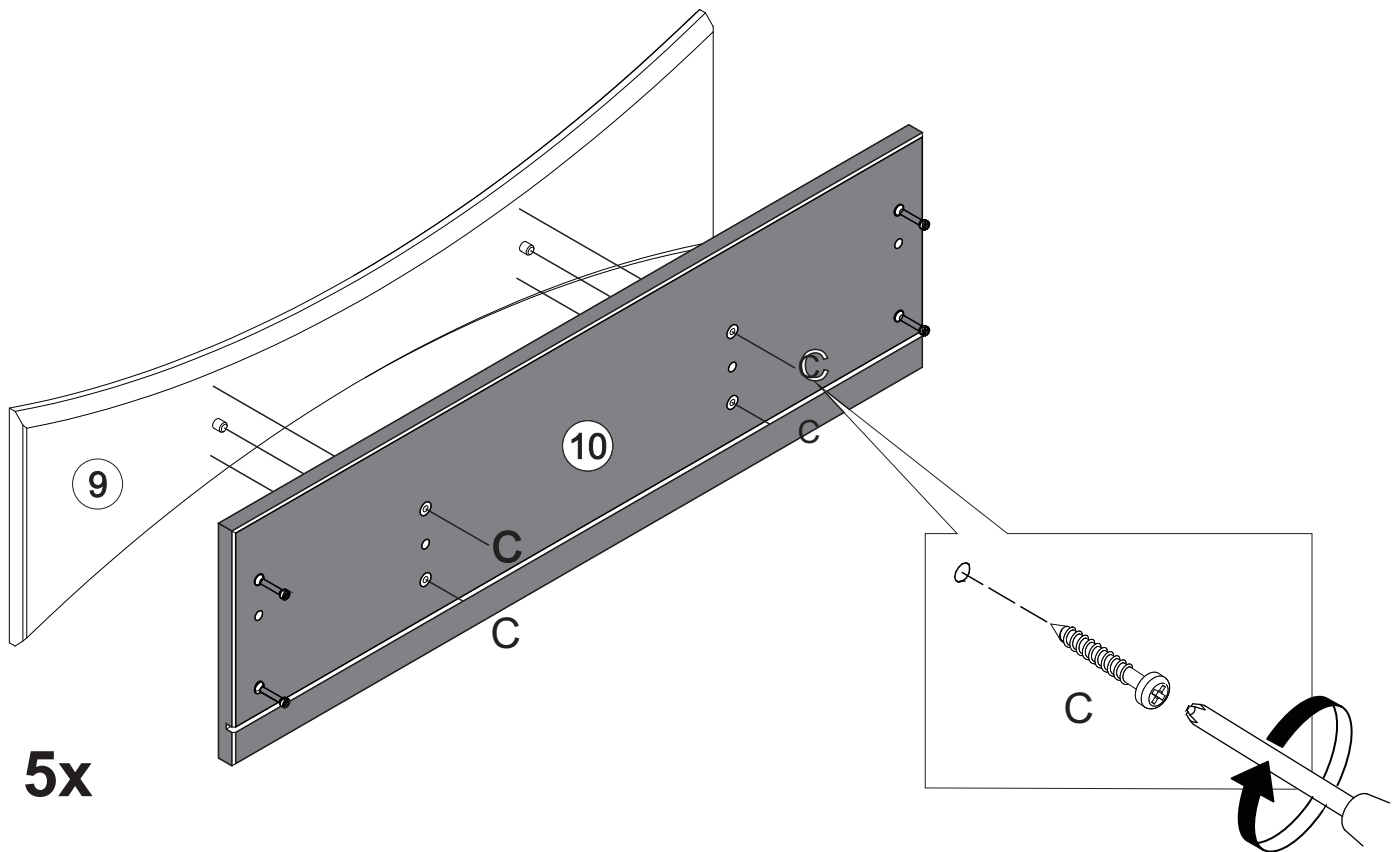
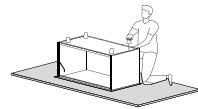

Step 12

Fit the Cam bolts (J) on Drawer front (10) to Left drawer side (11), Right drawer side (12) and Right drawer side with warning (15) and attach with Cam lock (K) and a philips head screwdriver.

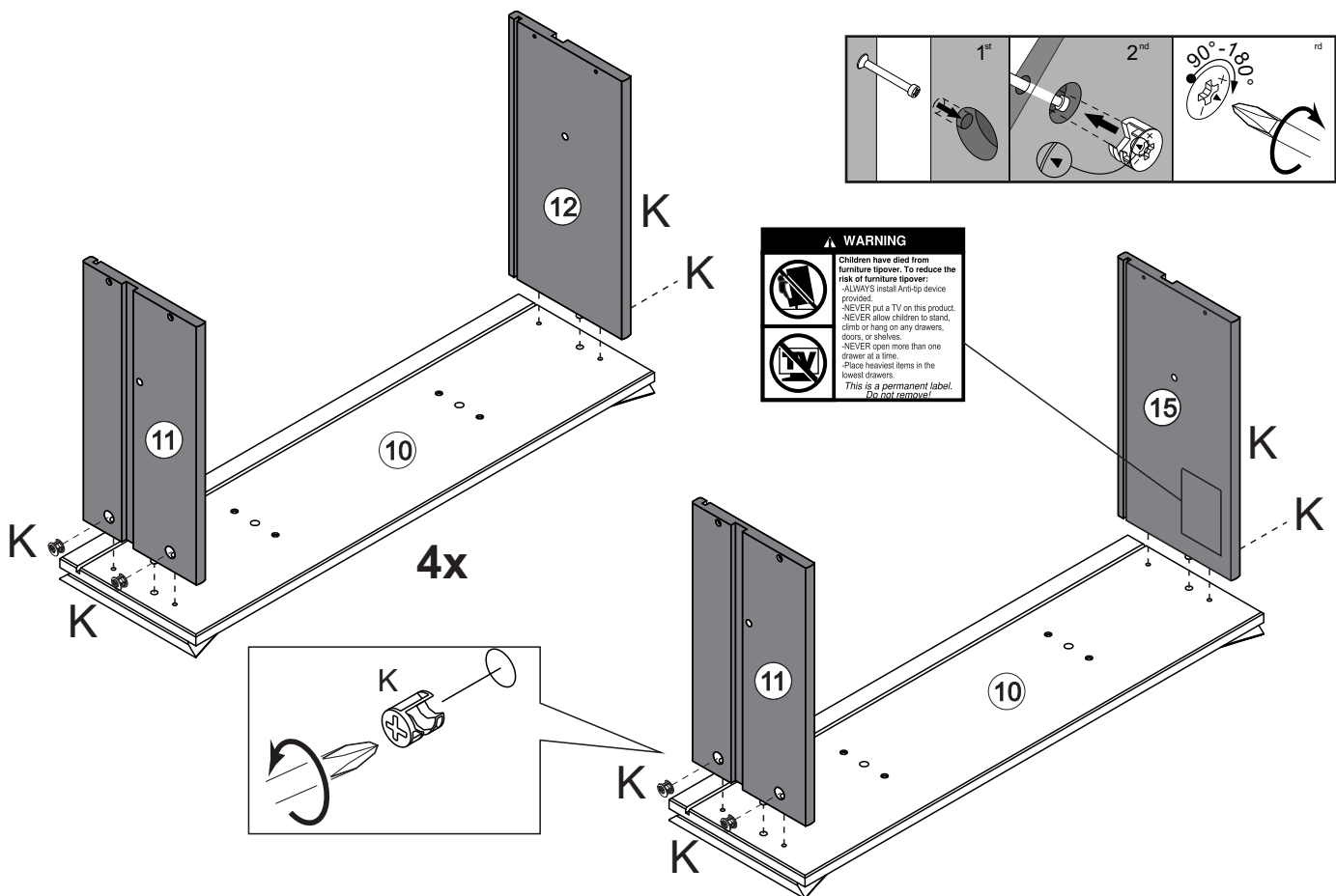
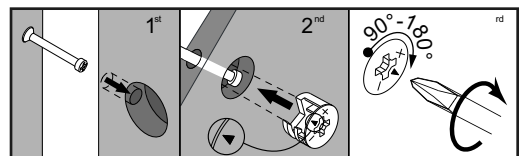
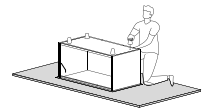

Step 13

Slide Drawer bottom (14) on the grooves on Right and Left drawer sides (11,12) fitting on Drawer front (10). Attach Drawer back (13) to Right and Left drawer side (11,12) using Screws (D), and a phillips head screwdriver.

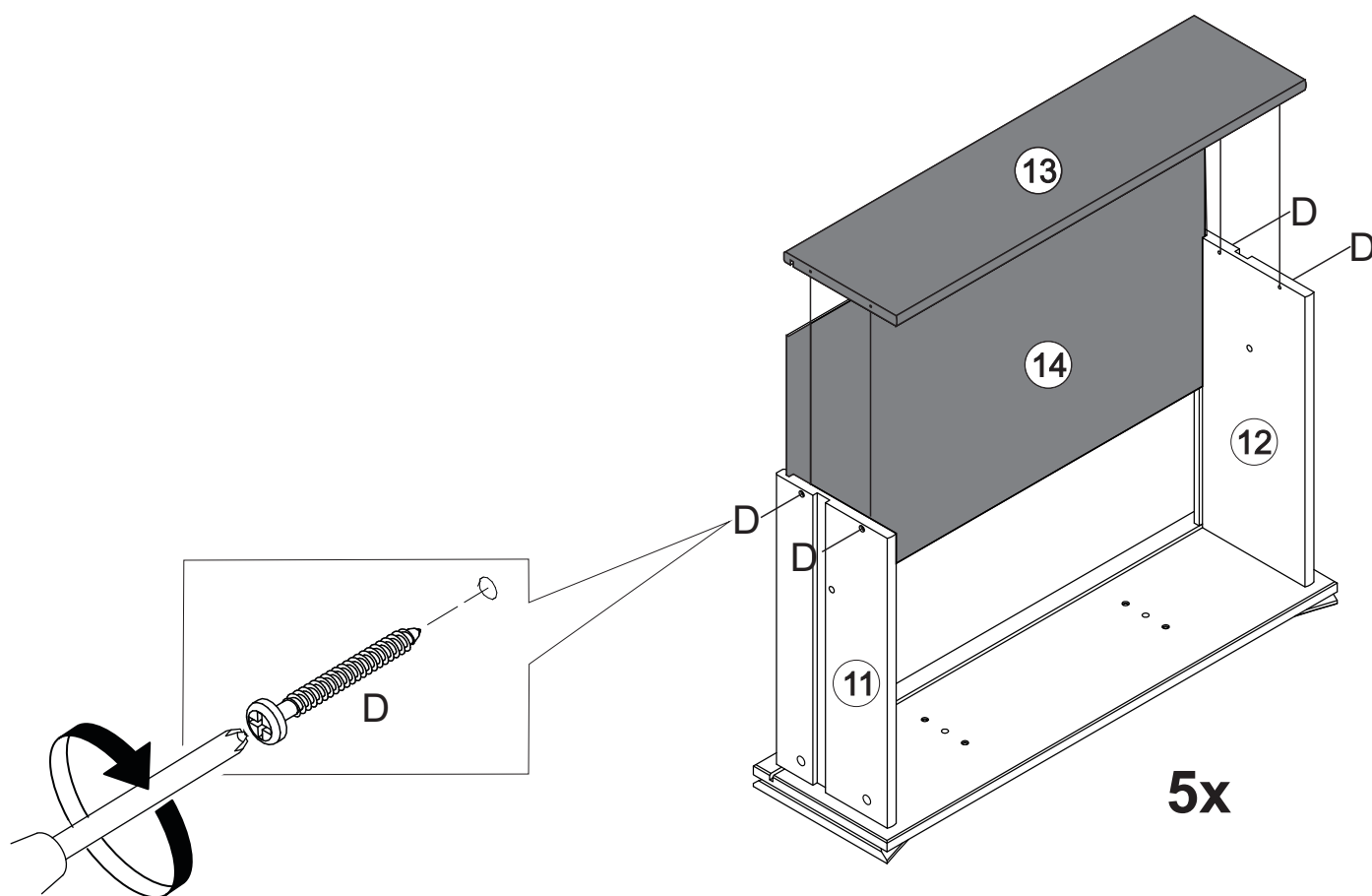

Step 14

Insert Wooden dowel (I) on the inside of all drawers, with the drawer inside the unit after having passed the wood dowel that is in the drawer slide. The dowel is not flush with the panel, it is a little inside the drawer to help when you need to remove the lock dowel to remove the drawer.

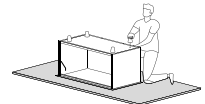
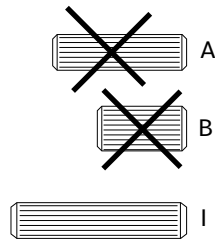

The assembled drawer with this warning must be placed on top of the unit.

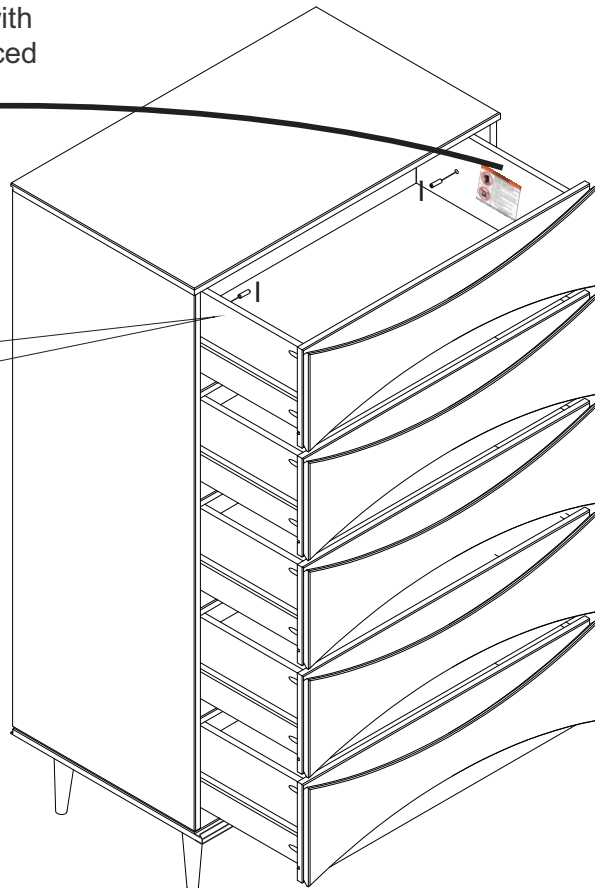
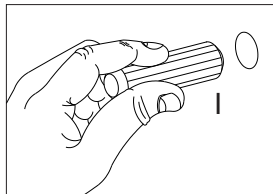

Step 15

To finish this up, let's secure your dresser to the wall!
Attach the Wall Anchor (L) to your dresser with a Washer (M)
and a Screw (O) using a Phillips Head Screwdriver.

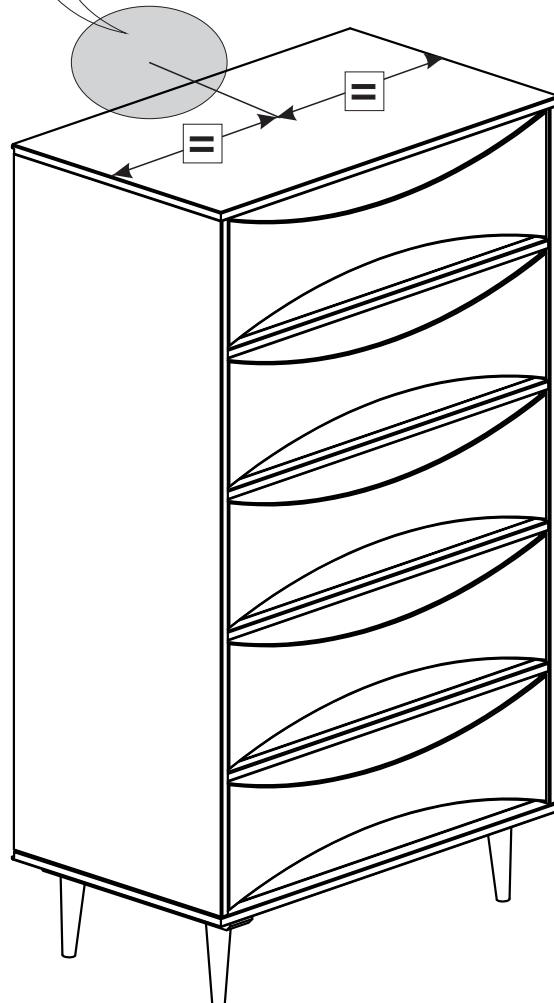
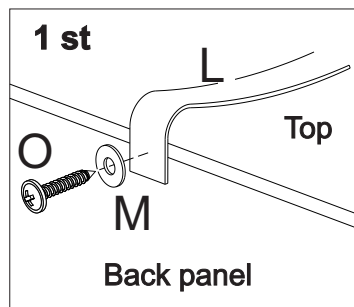

Step 16

Insert the Plastic bush (N) into the wall. Then, secure the Wall Anchor (L) to the wall using a Washer (M) and Screw (P).

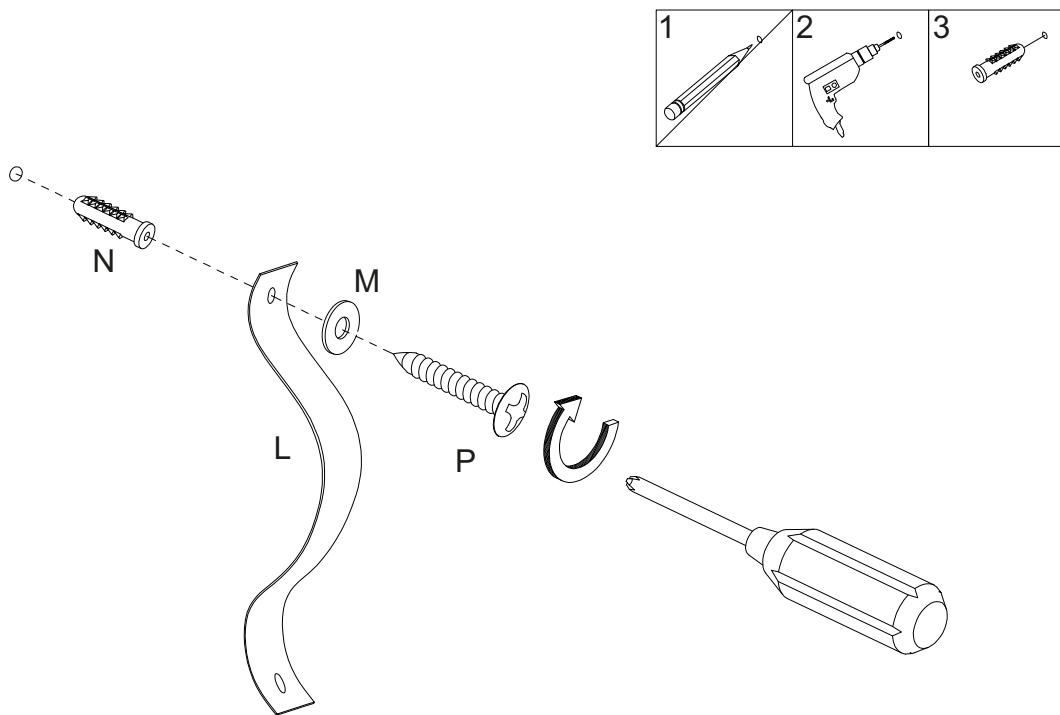

Warning

Serious or fatal injuries can occur from furniture tipping over. To prevent the furniture from tipping over we recommend that it is permanently fixed to the wall. Wall anchor and hardware are included with this product. Please make sure hardware is suitable for your walls before installing, as different wall materials may require different types of anchors.

Name and address information for the manufacturer responsible for the anti-tip hardware and date of production can be found on the label on the back of the furniture.

You did it! Enjoy your new Chest!

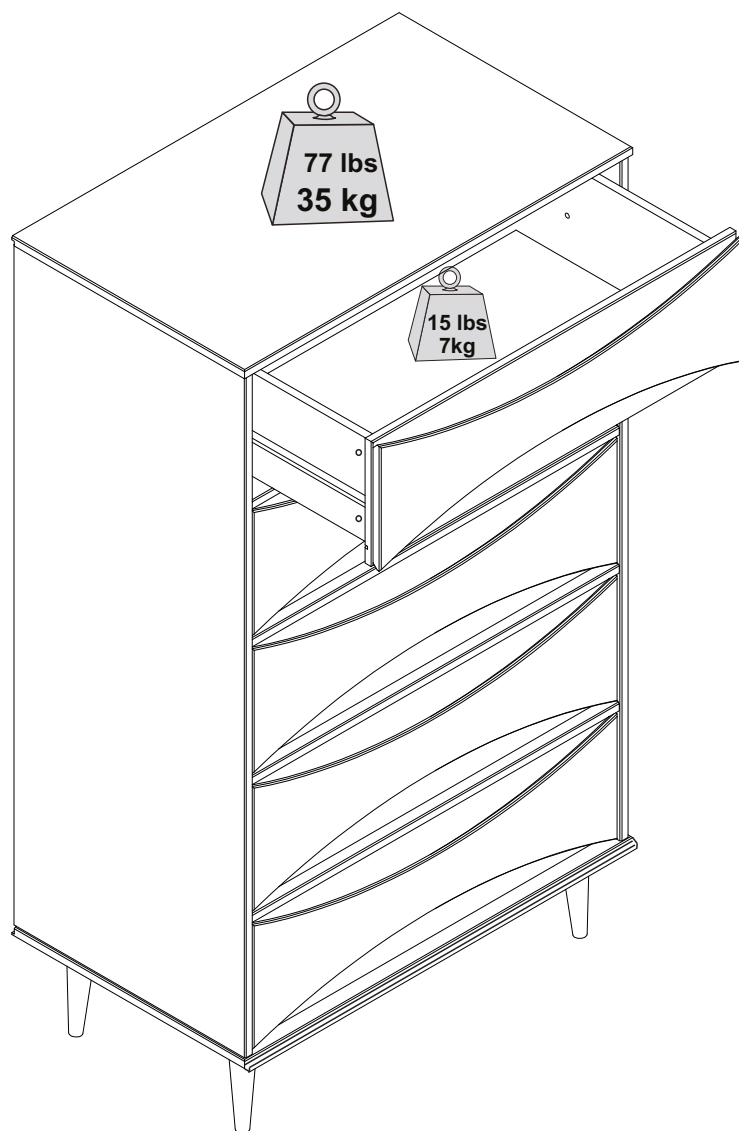

Congratulations on your new piece of furniture!
We would love to hear about it and see it.
Please leave us a review or post a picture with
[#mywalkerredisonhome](#)

Assembling furniture can be tricky sometimes.

Our customer service team, located in Utah, is here for product information, help assembling a product, or for any other customer support issue

Call us at **801-433-3008**

Email us at service@walkeredison.com

Visit our Customer Service website at walkeredison.com/pages/customer-service

We are available to help Monday-Thursday 8am-5pm, Friday 8am-3pm MST

For details on Assembly Videos, Assembly Instructions, Replacement Parts, and Customer service,

SCAN HERE

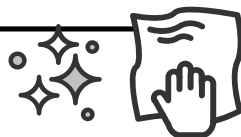

For cleaning, never use abrasives, use a soft cloth and water with neutral soap to clean the furniture.

WALKER EDISON™

Atticus Commode moderne du milieu du
siècle avec 5 Tiroir
Atticus Cómoda moderna de mediados de
siglo con 5 Cajónes

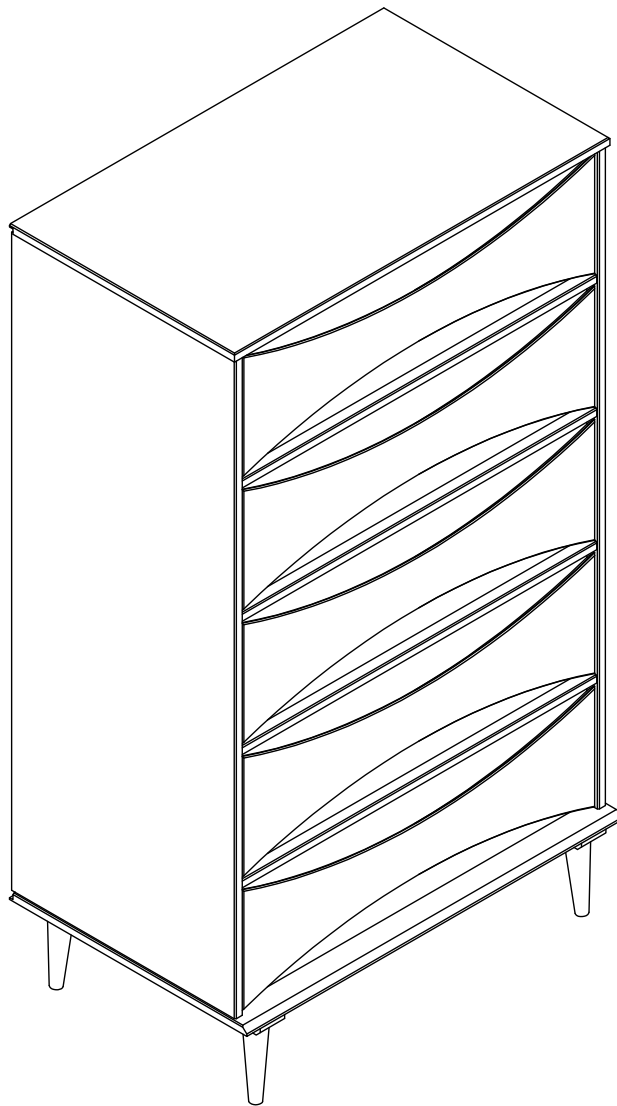

Pour usage résidentiel seulement

Visite notre site Web pour obtenir les instructions les plus récentes, des conseils d'assemblage, signaler des dommages ou commander des pièces. www.walkerredison.com

Sólo para uso residencial

Visite nuestro sitio web para consultar las últimas instrucciones, consejos de montaje, notificar daños o solicitar piezas. www.walkerredison.com

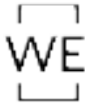

Il est temps de commencer / Hora de empezar

Prépare un lieu de travail propre et souple pour éviter tout dommage lors de l'assemblage. Tu peux utiliser la boîte et les protections internes comme base. Vérifie également que tu disposes de toutes les pièces et parties avant de te lancer dans l'assemblage.

Prepare un lugar de trabajo limpio y blando para evitar daños durante el montaje. Puede utilizar la caja y las protecciones internas como base. Comprueba también que tiene todas las piezas y partes antes de sumergirse en el montaje.

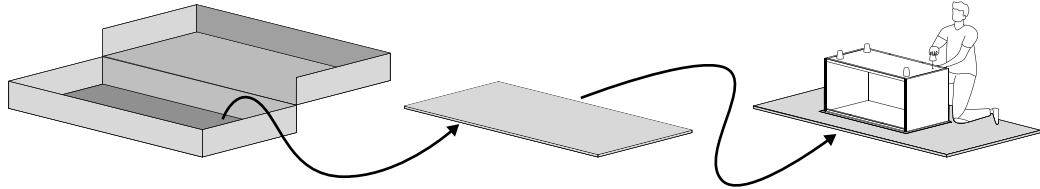

**Temps de montage
estimé**
**Tiempo estimado de
montaje**

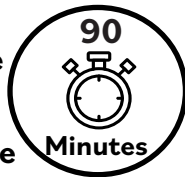

2 Personnes
2 Personas

Personnes recommandées pour le montage

Fais-en un effort d'équipe !
Appelle un ami pour un
assemblage plus rapide et plus
facile.

Personas recomendadas para el montaje

¡Hágalo en equipo!
Llame a un amigo para que el
montaje sea más rápido y sencillo.

Outils nécessaires

Munis-toi d'un tournevis cruciforme pour réaliser cet assemblage. Tu auras également besoin d'un marteau pour t'aider.

Herramientas requeridas

Tome un destornillador Phillips pour conquister este conjunto. También necesitaremos un martillo para ayudar.

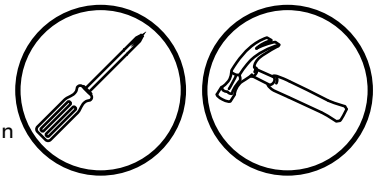

Utilise les outils électriques avec précaution

Ce meuble est réalisé en Bois Massif et Bois Composite, des matériaux souples. Si tu choisis d'utiliser des outils électriques, règle-les sur le mode le plus lent. Fais attention à toi ! Les outils électriques peuvent provoquer des fissures ou endommager les meubles, mais aussi les autres composants s'ils sont mal utilisés. Les dommages causés par un outil électrique ne sont pas couverts par la garantie Walker Edison.

Utilice las herramientas eléctricas con cuidado.

Este mueble está fabricado con madera maciza y madera compuesta, materiales blandos. Si decide utilizar herramientas eléctricas, ajústelas al ajuste más lento. Tenga cuidado. Las herramientas eléctricas pueden causar grietas o daños en el mueble, pero también en los herrajes si se utilizan mal.

Los daños causados por una herramienta eléctrica no están cubiertos por la garantía de Walker Edison.

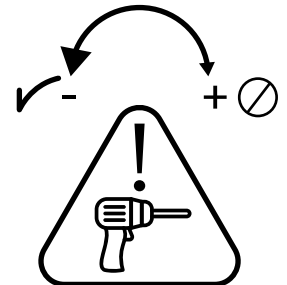

Cuidado com corredeira

Seus móveis possuem corredeiras de madeira de alta durabilidade. De vez em quando recomendamos a aplicação de parafina ou cera de vela padrão para melhorar o deslizamento dos controles deslizantes.

Cuidado com corredeira

Seus móveis possuem corredeiras de madeira de alta durabilidade. De vez em quando recomendamos a aplicação de parafina ou cera de vela padrão para melhorar o deslizamento dos controles deslizantes.

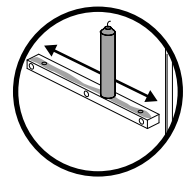

Scannez pour obtenir des conseils d'assemblage et de l'aide !
¡Escanee para obtener consejos de montaje y ayuda!

Liste de pièces / Lista de piezas

Nombre de pièces Número de pieza	Description Descripción	Quantité Cantidad
-------------------------------------	----------------------------	----------------------

1	Panneau Supérieur Panel Superior	1
2	Panneau Gauche Panel Izquierdo	1
3	Panneau Droit Panel Derecho	1
4	Panneau inférieur Panel inferior	1
5	Barre avant Travesaño delantero	4
6	Glissières en Bois Travesaño delantero	10
7	Pied Pie	2
8	Panneau arrière Panel trasero	2
9	Façade du tiroir Frente del Cajón	5

Nombre de pièces Número de pieza	Description Descripción	Quantité Cantidad
-------------------------------------	----------------------------	----------------------



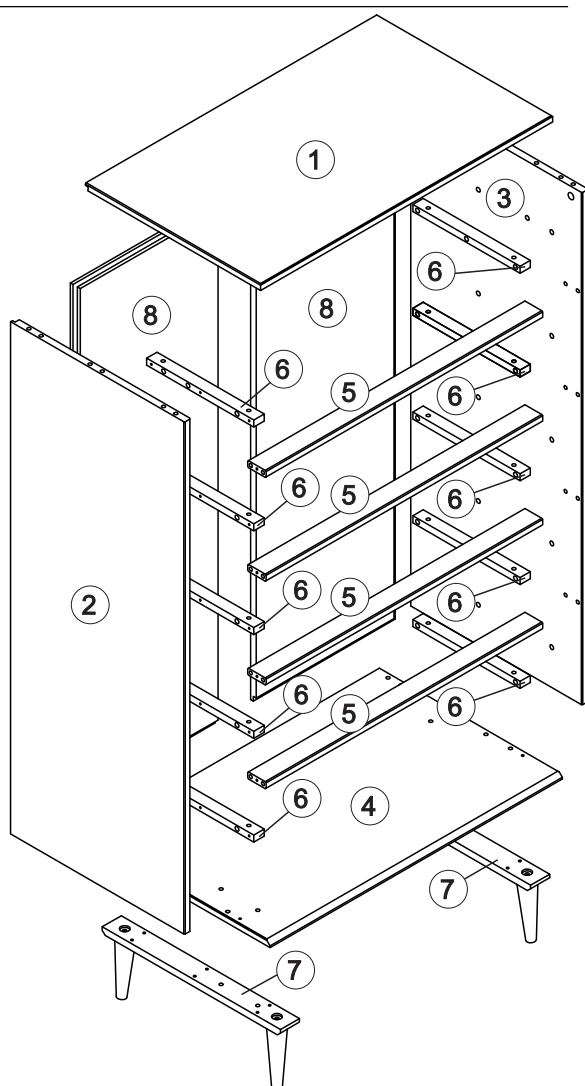



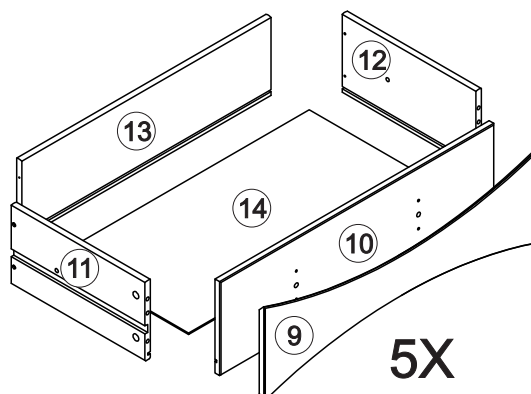
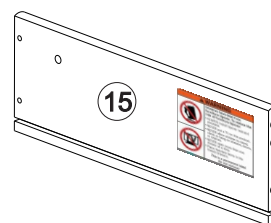

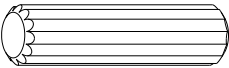
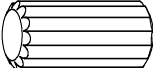

10	Façade du tiroir Frente del Cajón	5
11	Côté Gauche du tiroir Lado Izquierdo del Cajón	5
12	Côté Droit du tiroir Lado Derecho del Cajón	4
13	Arrière du tiroir Parte Trasera del Cajón	5
14	Fond du tiroir Fondo del Cajón	5
15	Côté Droit du tiroir avec avertissement Lado Derecho del Cajón con advertencia	1

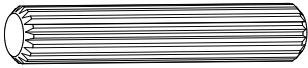
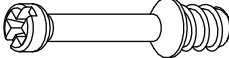

The side drawer with
WARNING LABEL, should
be mounted in highest drawer.



Liste de composants / Lista de hardware

Parte	Parte	Taille	Tamaño	Nom	Nombre	Quantité	Cantidad
A		Ø8*30mm		Cheville en bois	Espiga de madera	54	
B		Ø10*20mm		Cheville en bois	Espiga de madera	40	
C		Ø4,0*25mm		Vis	Tornillo	62	
D		Ø3,5*30mm		Vis	Tornillo	28	
E		Ø4,0*40mm		Vis	Tornillo	06	
F		Ø10*10mm		Clou	Clavo	36	
I		Ø8*40mm		Cheville en bois	Espiga de madera	10	
J		ø15*30mm		Goujoun de Assemblage	Conector	26	
K		ø15*10mm		Boitier de Assemblage	Traba del conector	26	
L				Courroie d'ancrage	Correa de anclaje	01	
M				Rondelle	Arandela	02	
N		Ø6*35mm		Cheville en Plastique	Taco Plástico	01	
O		Ø4*16mm		Vis	Tornillo	01	
P		Ø4,0*40mm		Vis	Tornillo	01	

Les quantités de composants indiquées ci-dessus sont nécessaires pour un assemblage correct.

Des pièces supplémentaires peuvent être incluses.

Las cantidades de tornillería indicadas anteriormente son necesarias para un montaje correcto.

Se pueden incluir piezas de ferretería adicionales.

Étape / Paso 1

(FR)

Commençons! Insère las Chevilles (B) dans le Grand Glissières en Bois (6) et Façade du tiroir (9).

(ES)

¡Manos a la obra! Inserta las Espigas (B) em las Correderas Grandes de Madera (6) y el Frente del Cajón (9).

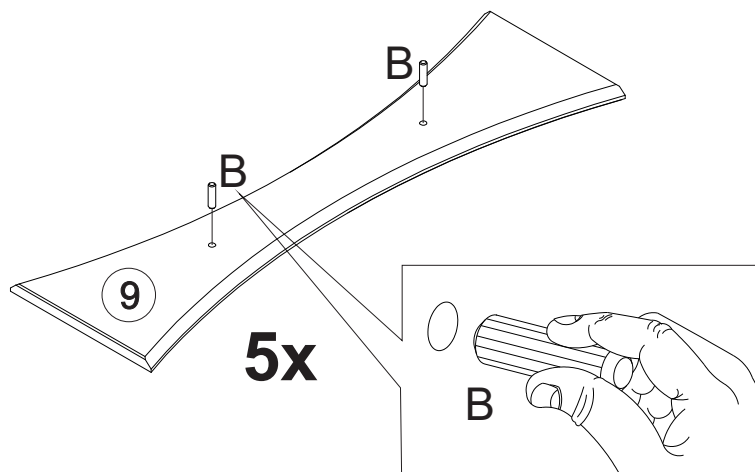
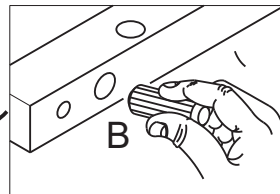
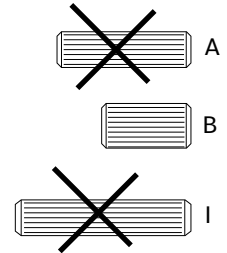
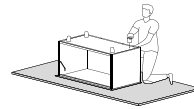
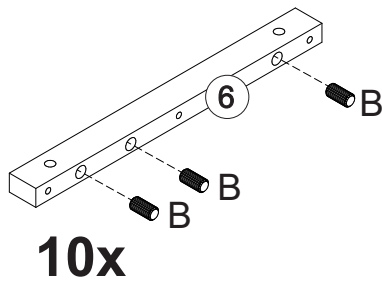

Cheville en bois

Les chevilles sont essentielles lors de l'assemblage de meubles pour créer des connexions solides et précises. Elles garantissent l'intégrité structurelle, empêchent les déplacements et simplifient l'alignement, ce qui permet d'obtenir des meubles plus résistants et plus durables. suis ces étapes :

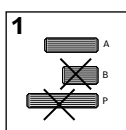

1: Sélectionne la taille de cheville appropriée en fonction de l'étape.
1: Seleccione el tamaño de espiga adecuado según el paso.

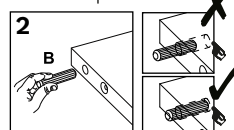

2: Insère dans le trou indiqué et appuie fermement pour assurer un positionnement correct.
2: Insértela en el orificio indicado y presione firmemente para asegurar su correcta colocación.

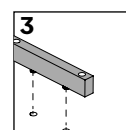

3: Alinee la cheville avec la pièce correspondante et enfonce-la jusqu'à ce qu'elle soit ferme.
3: Alinee el pasador con la pieza correspondiente y presiónelo hasta que encaje.

Espiga de madera

Las espigas son esenciales en el montaje de muebles para crear uniones fuertes y precisas.

Garantizan la integridad estructural, evitan el desplazamiento y simplifican la alineación, lo que se traduce en muebles más resistentes y duraderos.

Sigue estos pasos:

Étape / Paso 2

(FR)

Aussi insère les Chevilles (A) dans le Panneau Gauche (2), Panneau Droit (3), Barre Avant (5), Pied (7), Côté Gauche du tiroir (11), Côté Droit du tiroir (12) et Côté Droit du tiroir avec avertissement (15).

(ES)

También inserta las Espigas (A) en el Panel Izquierdo (2), Panel Derecho (3), Travesaño Delantero (5), Pies (7), Lado Izquierdo del Cajón (11), Lado Derecho del Cajón (12) y Lado Derecho del Cajón con Advertencia (15)

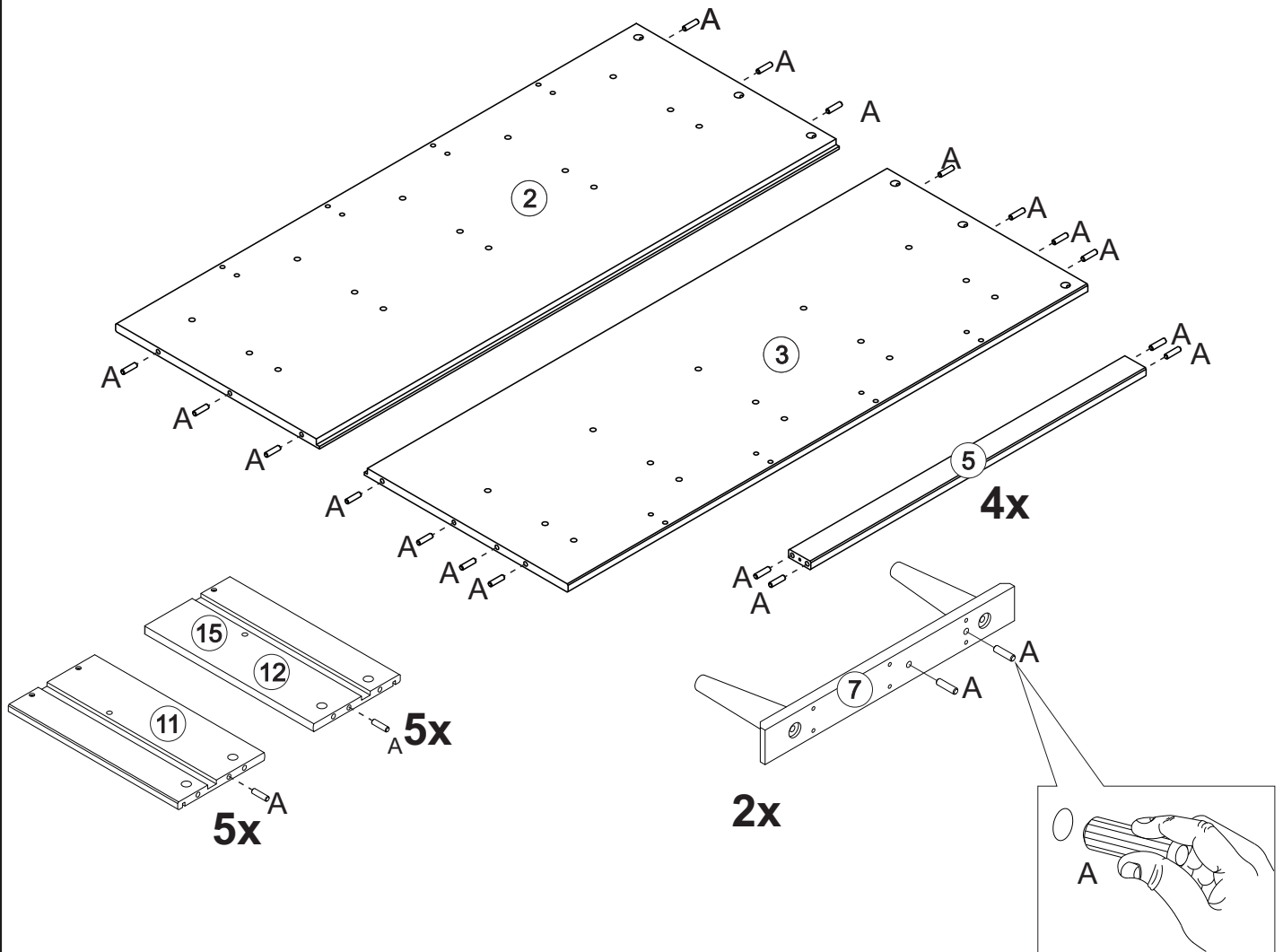
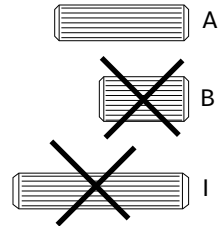
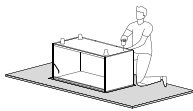

Tip
Pour que ton produit conserve son meilleur aspect et sans rayures, essaie de le monter sur une surface souple telle qu'un tapis ou une couverture. Cela permet d'éviter les rayures accidentelles et de garder tes meubles en bon état!



Para mantener su producto con el mejor aspecto y sin arañazos, pruebe a montarlo sobre una superficie blanda, como una alfombra o una manta. Así evitará arañazos accidentales y mantendrá sus muebles en perfecto estado.

Étape / Paso 3

(FR) Attacher Goujon de Assemblage (J) dans le Panneau Supérieur (1) et Façade du Tiroir (10) utilisant un tournevis Phillips.

(ES) Fija los Conectores (J) al Panel Superior (1) y Frente del Cajón (10) utilizando un destornillador Phillips.

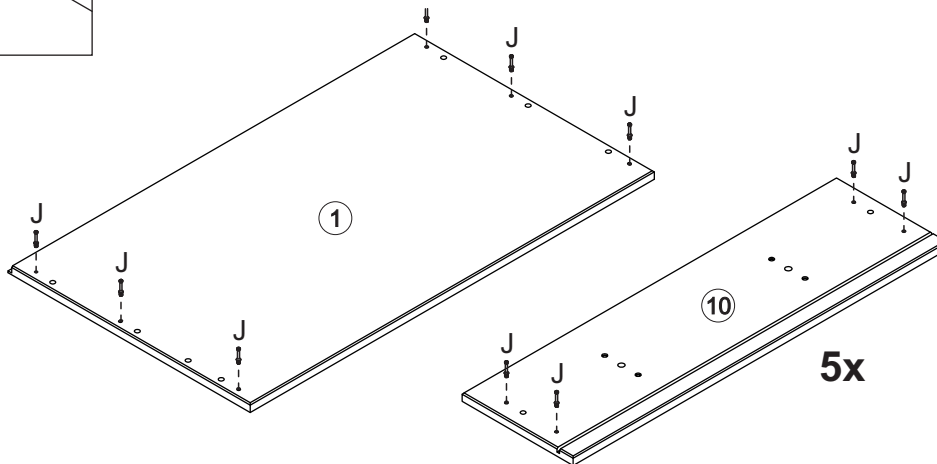
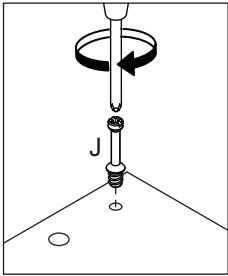

Étape / Paso 4

(FR) Fixer Grand Glissières en Bois (6) au Panneau Gauche (2) et Panneau Droit (3) utilisant Vis (C) et le tournevis Phillips.

(ES) Fija las Correderas Grandes de Madera (6) al Panel Izquierdo (2) y Panel Derecho (3) utilizando el Tornillo (C) y un destornillador Phillips

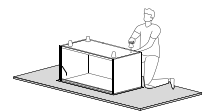
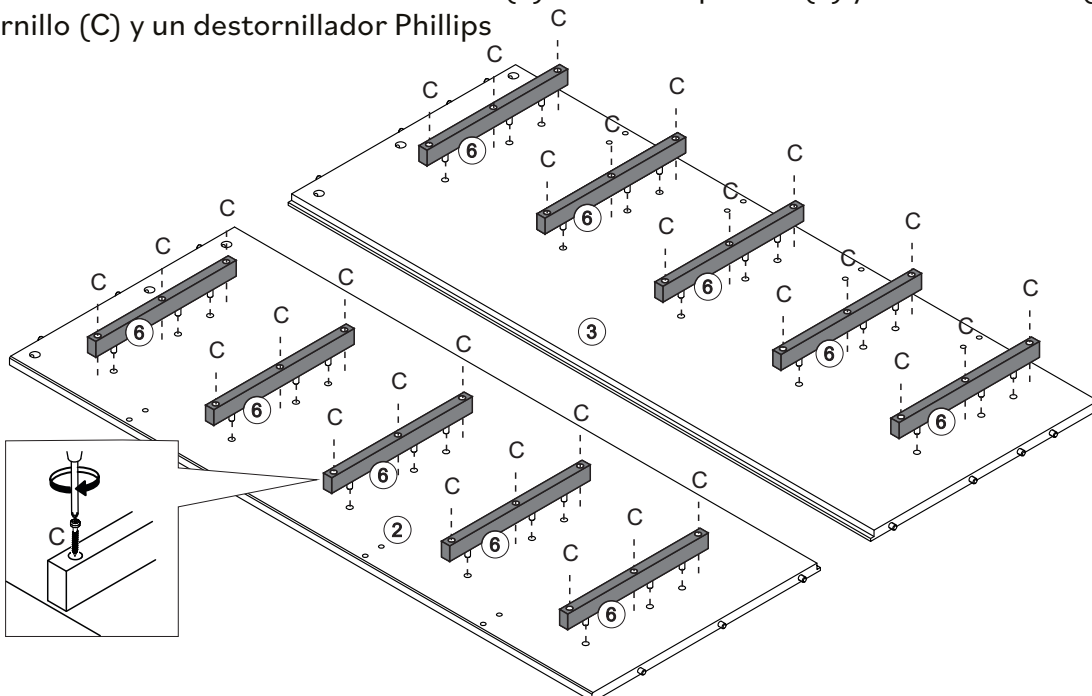

Étape / Paso 5

(FR) Monte le Barre Avant (5) au Panneau Gauche (2) et Panneau Droit (3) utilisant Vis (D) et le tournevis Phillips.

(ES) Monta el Travesaño Delantero (5) al Panel Izquierdo (2) y Panel Derecho (3) utilizando Tornillo (D) y un destornillador Phillips.

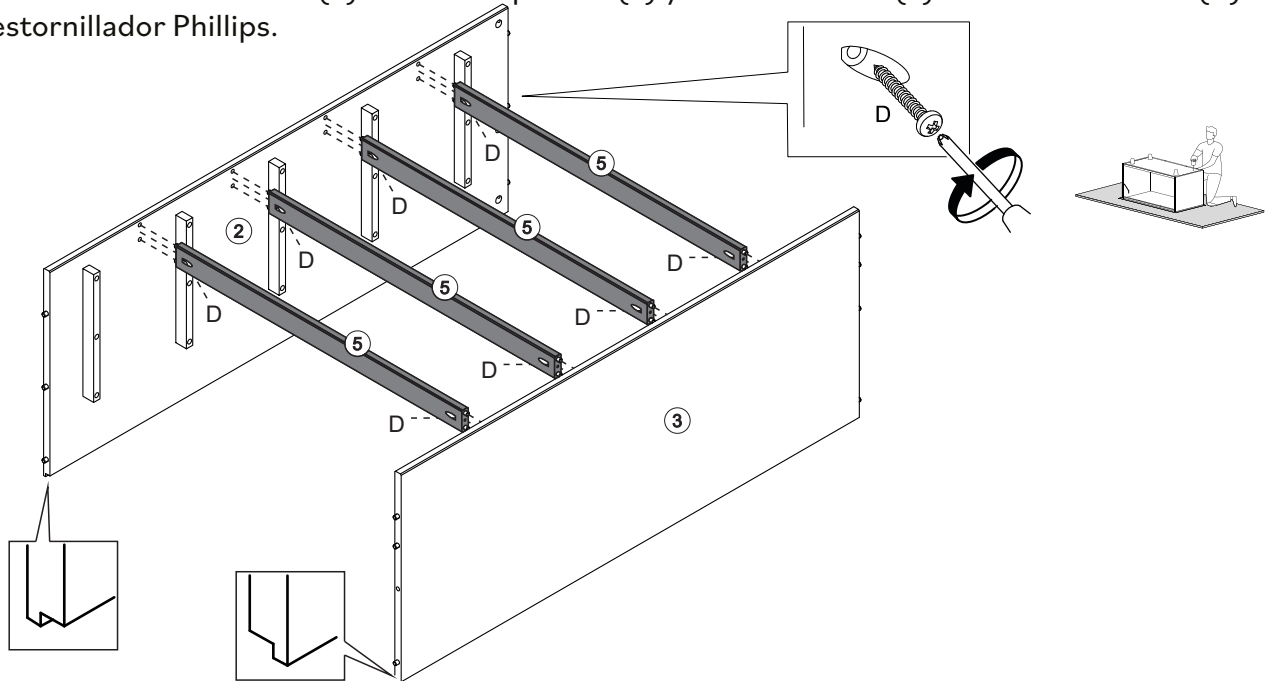

Étape / Paso 6

(FR) Attacher Panneau Inférieur (4) au Panneau Gauche (2) et Panneau Droit (3) utilisant Vis (E) et tournevis Phillips.

(ES) Fija el Panel Inferior (4) al Panel Izquierdo (2) y Panel Derecho (3) utilizando Tornillo (E) y un destornillador Phillips.

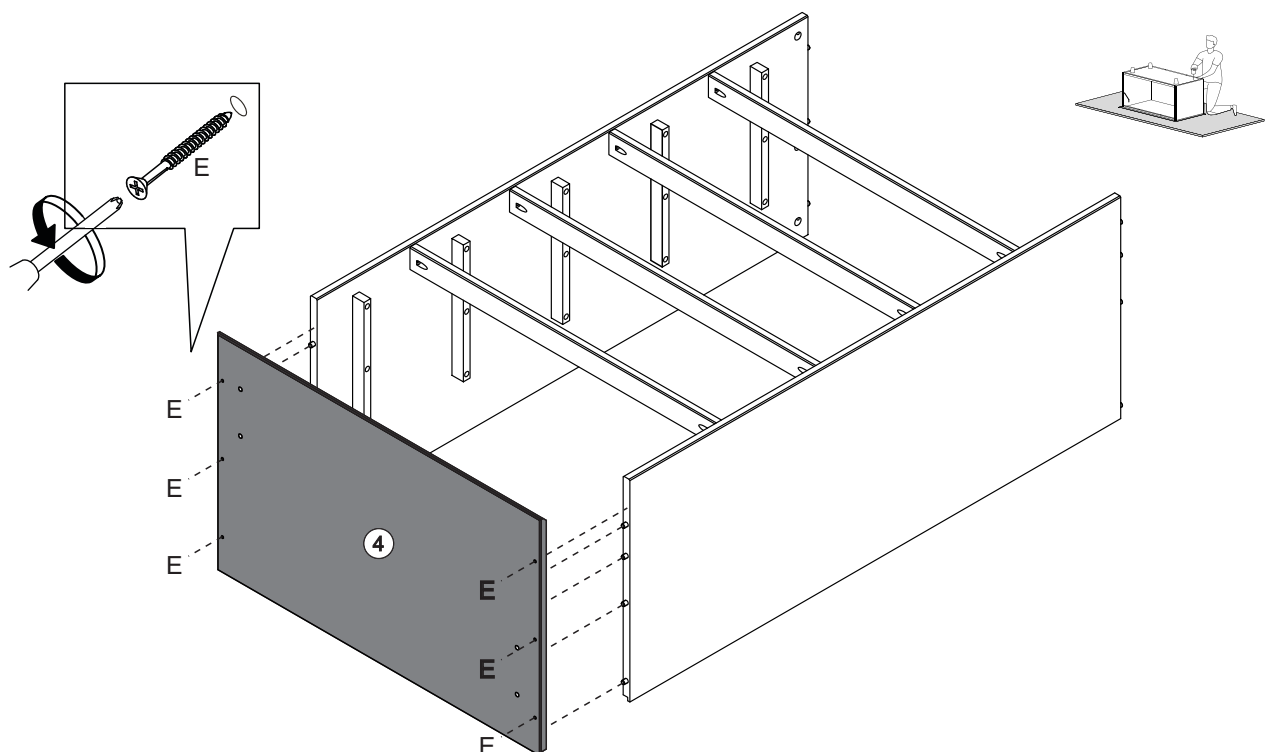

Étape / Paso 7

(FR) Monte les Pieds (7) au Panneau Inférieur (4) utilisant Vis (C) et le tournevis Phillips.
 (ES) Asegure los Pies (7) al Panel Inferior (4) usando el Tornillo (C) y un destornillador Philips.

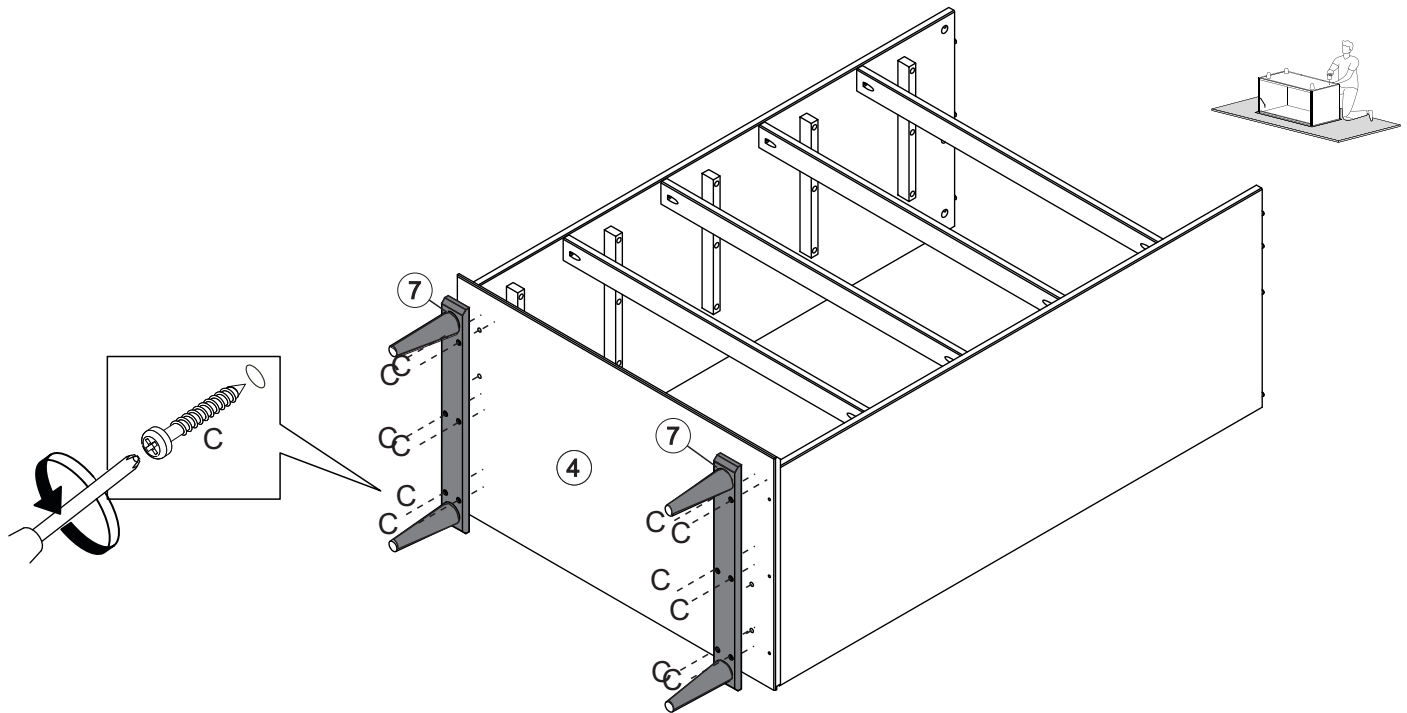

Étape / Paso 8

(FR) Attacher Panneau Supérieur (1) au Panneau Gauche (2) et Panneau Droit (3) utilisant Boitier de Assemblage (K) et le tournevis Phillips.
 (ES) Fije el Panel Superior (1) al Panel Izquierdo (2) y Panel Derecho (3) usando la Traba del Conector (K) y un destornillador Phillips.

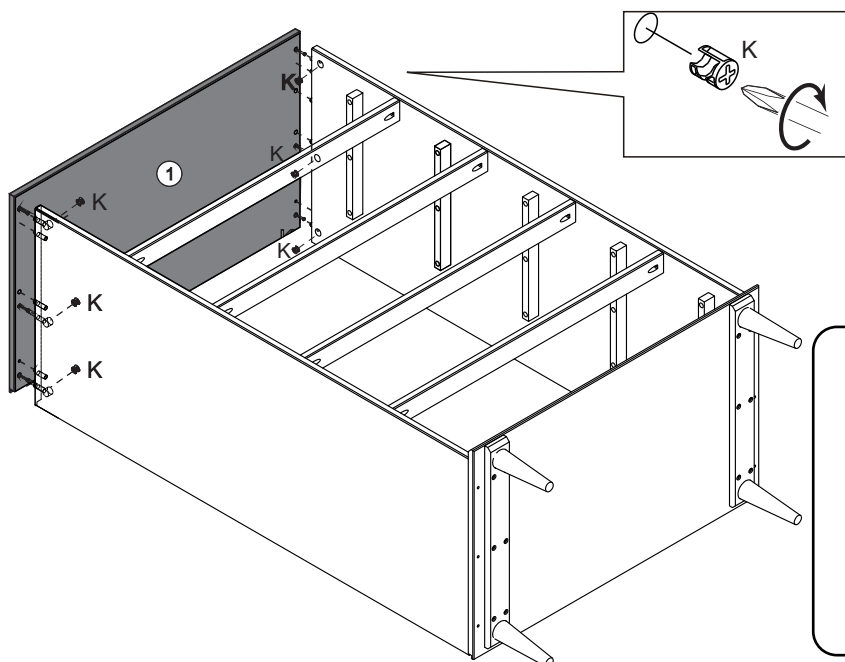

Tip
Mini Fix
 Mini Fix permet de joindre deux pièces en toute sécurité. Suis ces étapes simples.

Mini Fix
 Los tornillos Mini Fix ayudan a unir de forma segura dos piezas. Sigue estas fáciles etapas.

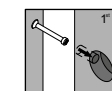

1: Insère le Mini Fix dans les orifices du côté plat. Ne serre pas trop!
 1: Coloca el tornillo Mini Fix en los orifices del lado plano. ¡No aprietes demasiado!

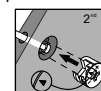

2: Une les pièces de bois. Les vis Mini Fix entrent dans les orifices qui ont des trous sur les côtés, tu dois pouvoir voir les vis Mini Fix à travers ceux-ci. Après avoir installé les pièces, insère le tambour Mini Fix dans les orifices latéraux.

2: Una las piezas de madera. Los tornillos Mini Fix entran en las piezas que tienen orificios en los lados, por lo que deberías poder ver los tornillos Mini Fix a través de ellos. Después de encajar las piezas, inserta el tambor del tornillo Mini Fix en los orificios laterales.



3: Sur la partie arrière du tambour, il aura la forme d'un « C ». Insère le tambour de manière à ce que l'ouverture « C » s'embote à la vis Mini Fix. Serre-la avec le tournevis.

3: La parte posterior del tambor tendrá la forma de « C ». Inserta el tambor de modo que la abertura de la « C » encaje en el tornillo Mini Fix. Apriétalo con un destornillador.

Étape / Paso 9

(FR) Insère les Chevilles (A) dans le Grand Glissières en Bois (6)
 (ES) Inserta las Espigas (A) en las Correderas Grandes de Madera (6)

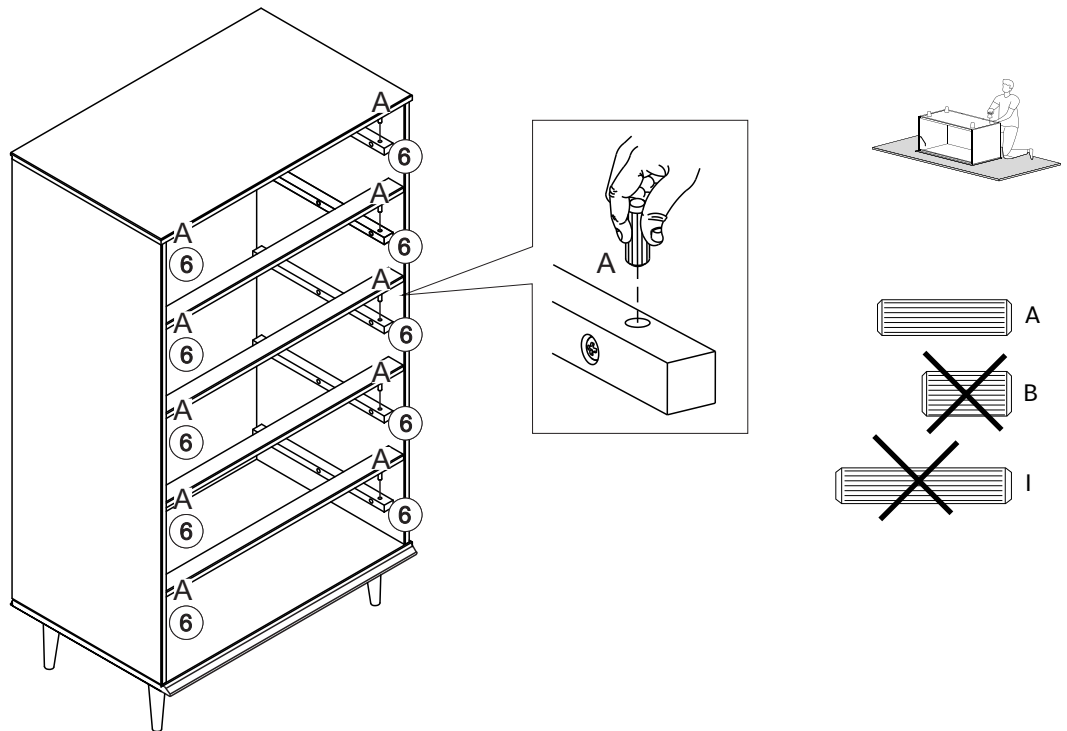

Étape / Paso 10

(FR) Pour fixer le Panneau Arrière (8) utilisant Clou (N) et le marteau.
 (ES) Fija el Panel Trasero (8) usando Clavos (F) y um martillo.

Nom et adresse du fournisseur et date de production. / Nombre y dirección del proveedor y fecha de producción

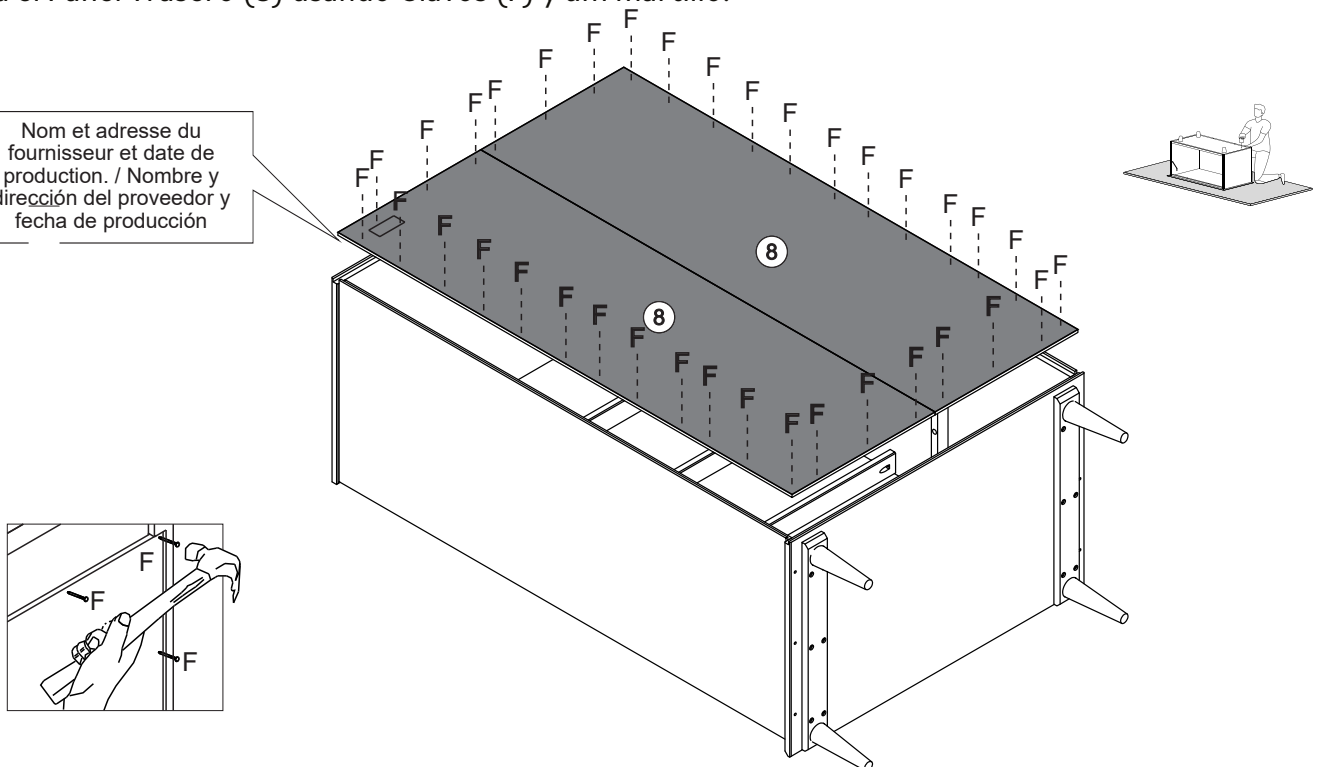

Étape / Paso 11

(FR) Assemblez la façade du tiroir en joignant la façade du tiroir (09) à la façade du tiroir (10), à l'aide des vis (C) et d'un tournevis Phillips.

(ES) Ensamble el frente del cajón uniendo el frente del cajón (09) al frente del cajón (10), usando tornillos (C) y un destornillador Phillips.

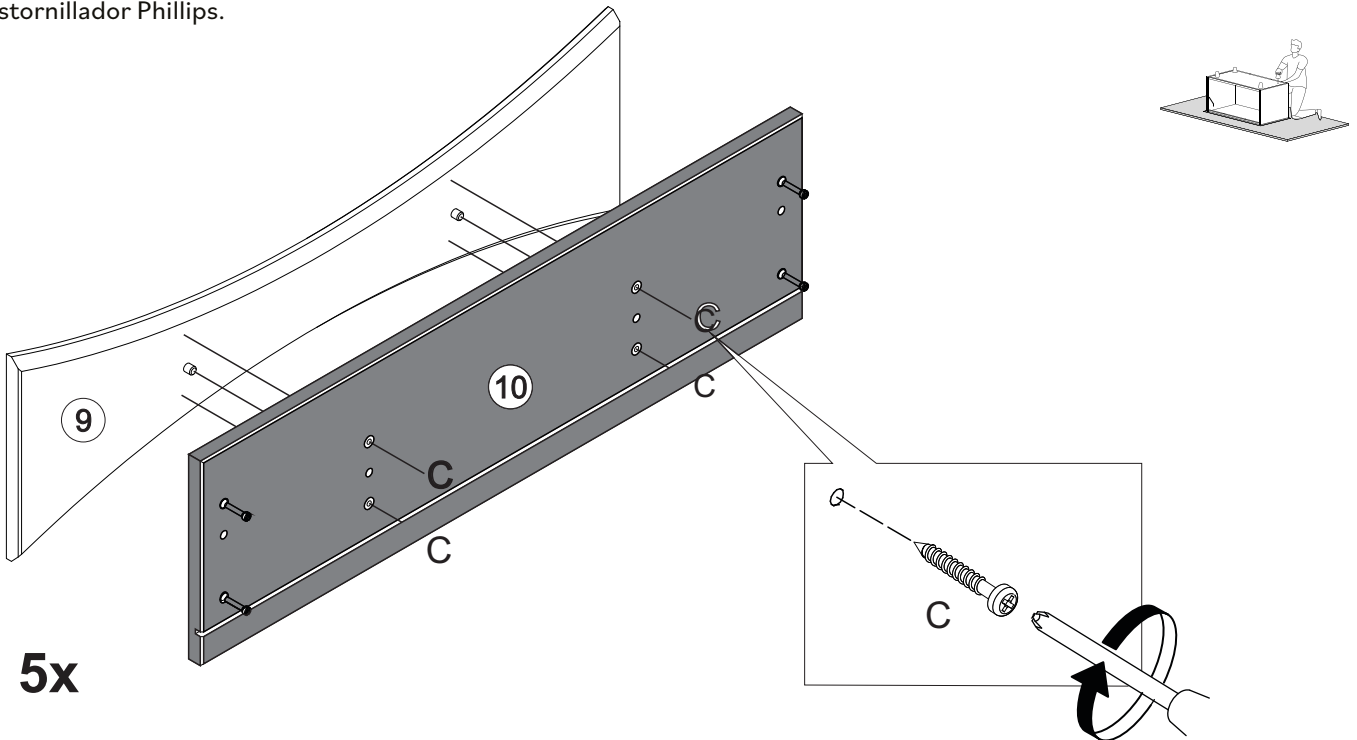

Étape / Paso 12

(FR) Installez les Boitiers de Assemblage (J) sur la façade du tiroir (10) dans le Côté Gauche du Tiroir (11), le Côté Droit du Tiroir (12) et le Côté Droit du Tiroir avec l'Avertissement (15) et fixez-les avec le Boitiers de Assemblage (K) et un tournevis Phillips.

(ES) Coloque los Conectores (J) del Frente del Cajón (10) en el Lado Izquierdo del Cajón (11), en el Lado Derecho del Cajón (12) y en el Lado Derecho del Cajón con Advertencia (15) y fijelos con la Traba del Conector (K) y un destornillador Phillips.

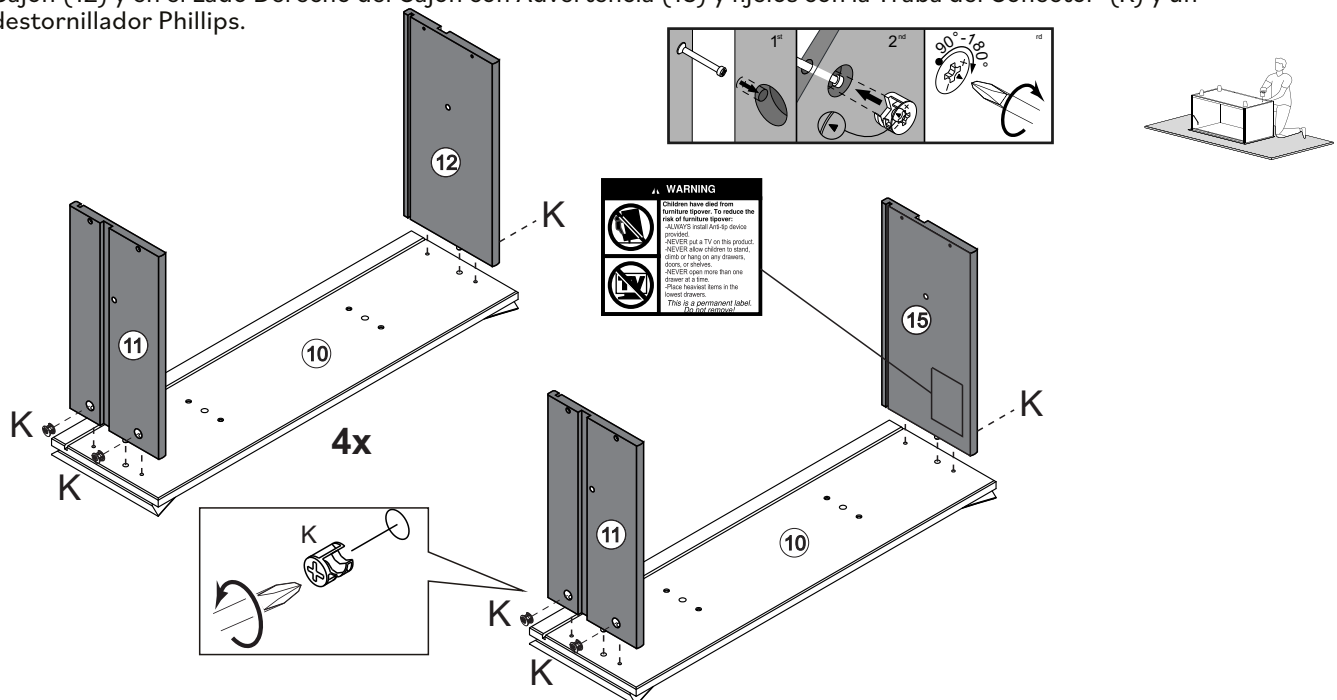

Étape / Paso 13

(FR)

Faites le Fond du Tiroir (14) sur les rainures des Côtés Droit et Gauche du Tiroir (11, 12) en s'adaptant à la Façade du Tiroir (10). Fixez l'Arrière du Tiroir (13) aux Côtés Droit et Gauche du Tiroir (11, 12) à l'aide des Vis (D) et d'un tournevis phillips.

(ES)

Deslice el Fondo del Cajón (14) en las ranuras de los Lados Derecho e Izquierdo del cajón (11,12) hasta encajar en el Frente del Cajón (10). Fije la Parte Trasera del Cajón (13) al Lado Derecho e Izquierdo del Cajón (11,12) usando Tornillos (D) y un destornillador Phillips.

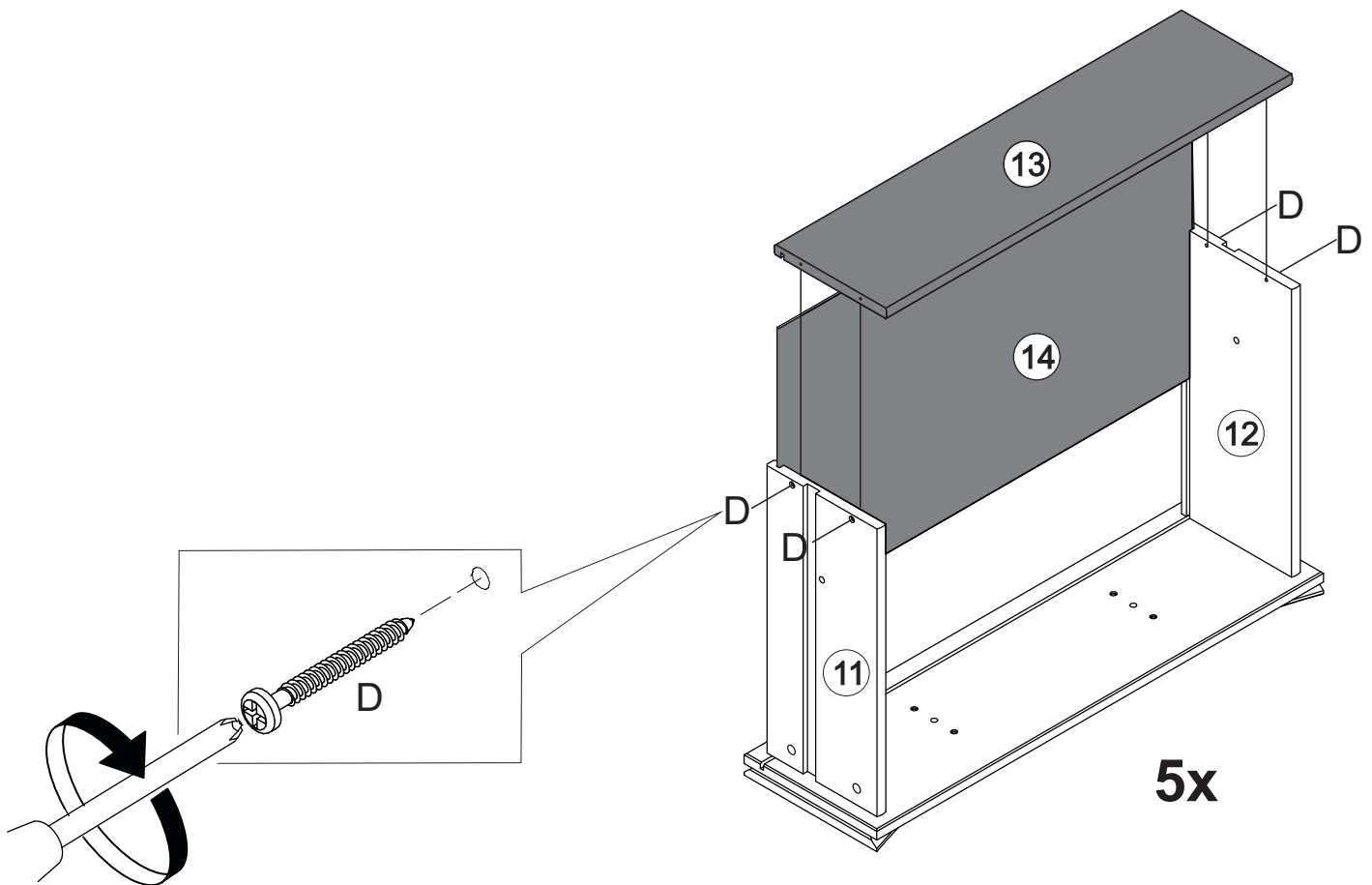

Étape / Paso 14

(FR)

Insérez la cheville en bois (I) à l'intérieur de tous les tiroirs, avec le tiroir à l'intérieur du meuble après avoir passé la cheville en bois qui se trouve dans la glissière du tiroir. La cheville n'est pas à fleur du panneau, elle se trouve un peu à l'intérieur du tiroir pour vous aider lorsque vous devez retirer la cheville de verrouillage pour retirer le tiroir.

(ES)

Inserte las Espigas (I) en el interior de todos los cajones, con el cajón dentro de la unidad después de haber pasado la espiga que se encuentra en la corredera del cajón. La espiga no está al ras con el panel, está un poco dentro del cajón para ayudar cuando necesite quitar la espiga de bloqueo para quitar el cajón.

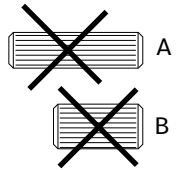
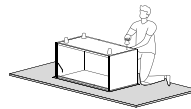

The assembled drawer with this warning must be placed on top of the unit.

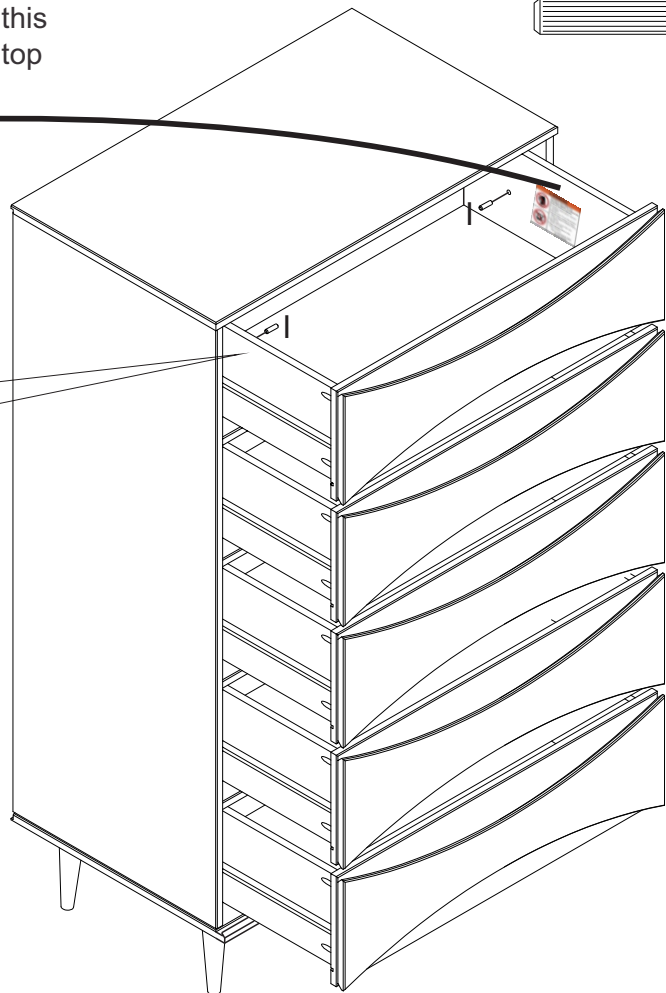
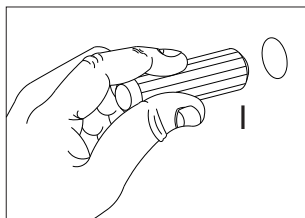

Étape / Paso 15

(FR)

Pour finir, fixons votre commode au mur !

Fixez l'ancrage mural (L) à votre commode avec une rondelle (M) et une vis (O) à l'aide d'un tournevis Phillips.

(ES)

Para terminar, ¡aseguremos su cómoda a la pared!

Fije el anclaje de pared (L) a su tocador con una arandela (M) y un tornillo (O) usando un destornillador Phillips.

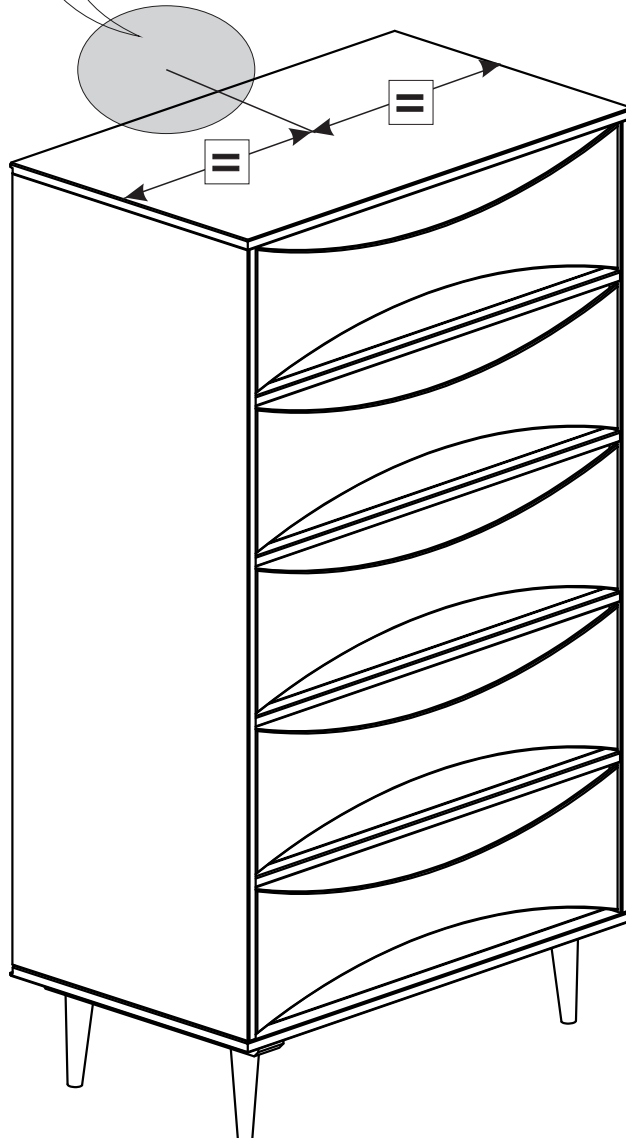
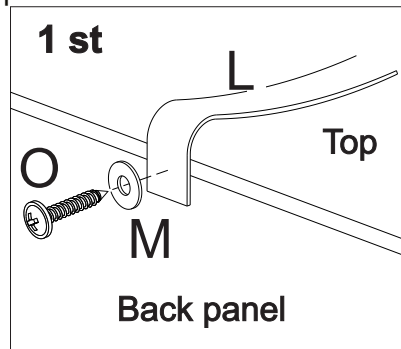

Étape / Paso 16

(FR)

Insère la cheville en plastique (N) dans le trou du mur. Ensuite fixe le ruban (L) au mur à l'aide de la rondelle (M) et des vis (P).

(ESP)

Coloca el tapón de plástico (N) en el orificio de la pared. Luego, fija el cordón (L) a la pared usando la arandela (M) y el tornillo (P).

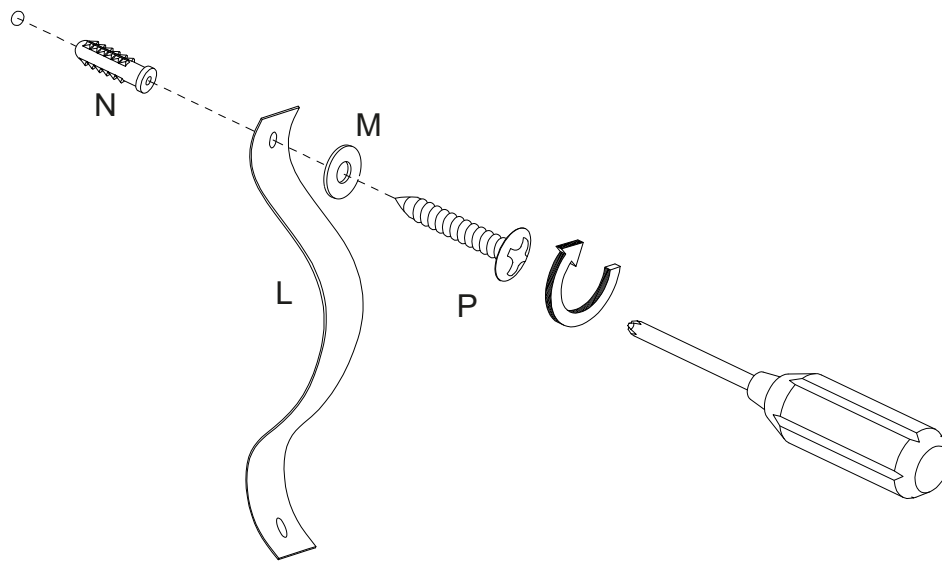
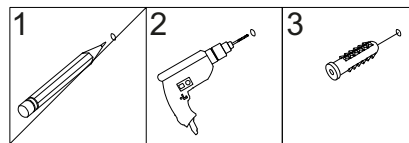

Avertissement

Des blessures graves, voire mortelles, peuvent survenir en cas de renversement de meubles. Pour éviter que le meuble ne bascule, nous recommandons de le fixer définitivement au mur. L'ancrage mural et les autres composants sont inclus dans ce produit. Assure-toi que les composants sont adaptés à tes murs avant l'installation, car différents matériaux de mur peuvent nécessiter différents types d'ancrages.

Le nom et l'adresse du fabricant responsable des composants anti-basculer ainsi que la date de production se trouvent sur l'étiquette au dos du meuble.

Advertencia

Pueden ocurrir lesiones graves o fatales debido a la caída de muebles. Para evitar que los muebles se caigan, recomendamos que se fijen permanentemente a la pared. El anclaje de pared y los herrajes están incluidos en este producto. Asegúrate de que los herrajes sean adecuados para tus paredes antes de la instalación, ya que diferentes materiales de pared pueden requerir diferentes tipos de anclajes.

El nombre y la dirección del fabricante responsable de los herrajes antivuelco y la fecha de producción se pueden encontrar en la etiqueta de la parte trasera de los muebles.

Tu as réussi ! Profite de ton nouveau Chest!

¡Lo ha conseguido! ¡Disfrute de su nueva Chest!

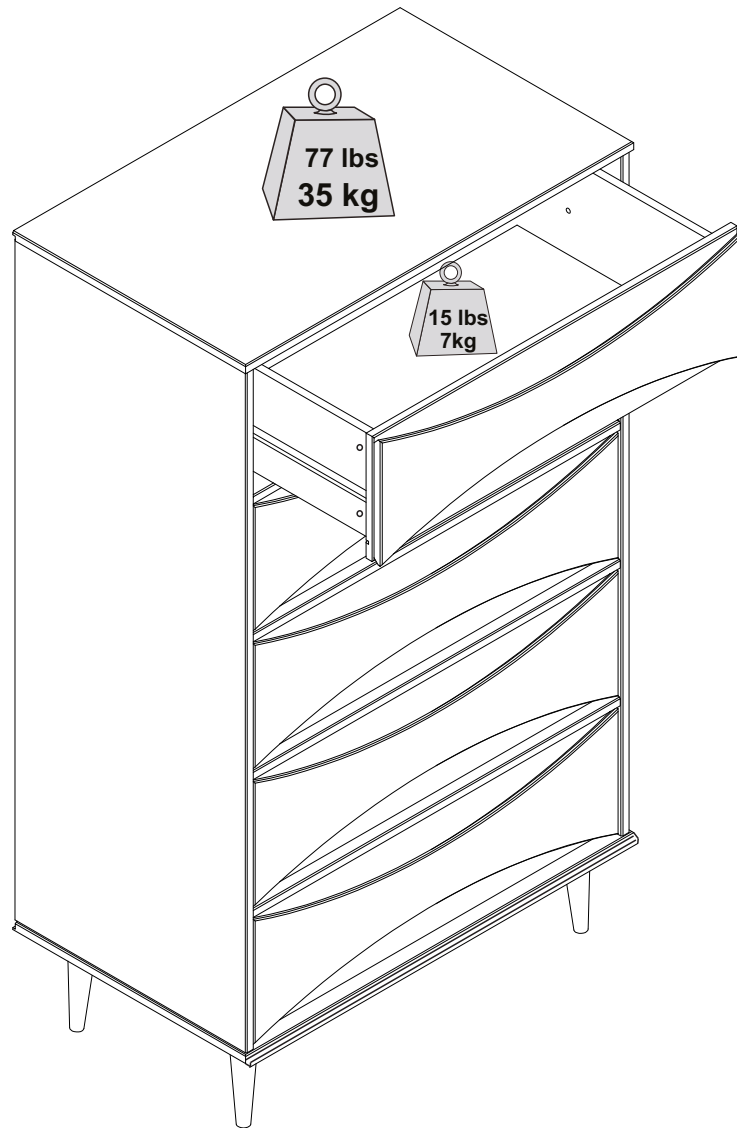

Bravo pour ton nouveau meuble !

Nous aimerions t'en entendre parler et le voir.

S'il te plait, laisse-nous un commentaire ou publie une photo sur

#mywalkerredisonhome

¡Enhorabuena por sus nuevos muebles!

Nos encantaría oírlo y verlo.

Por favor, déjenos un comentario o publique una foto con

#mywalkerredisonhome

Assembler des meubles peut parfois être compliqué.

Notre équipe de service client, située dans l'Utah, est là pour obtenir des informations sur les produits, aider pour l'assemblage d'un produit ou pour tout autre problème de support client.

Appelle-nous **801-433-3008**

Envoie-nous les e-mails à service@walkeredison.com

walkeredison.com/pages/customer-service

Nous sommes disponibles pour t'aider du Lundi au Jeudi de 8 am - 5 pm, Vendredi de 8 am - 3 pm MST.

Pour plus de détails sur les vidéos d'assemblage, les instructions d'assemblage, les pièces de rechange et le service client.

NUMÉRISER ICI.



Pour le nettoyage, n'utilise jamais d'abrasifs, utilise un chiffon doux et de l'eau avec du savon neutre pour nettoyer les meubles.

A veces, montar muebles puede resultar complicado.

Nuestro equipo de atención al cliente, ubicado en Utah, está a su disposición para informarle sobre los productos, ayudarle a montarlos o resolver cualquier otro problema de atención al cliente.

Llámenos **801-433-3008**

Envíenos un correo electrónico a service@walkeredison.com

Visite nuestra página web de atención al cliente

walkeredison.com/pages/customer-service

Estamos a su disposición para ayudarle de lunes a jueves de 8:00 a 17:00, viernes de 8:00 a 15:00 MST.

Para más detalles sobre videos de montaje, instrucciones de montaje, piezas de recambio y servicio de atención al cliente

ESCANEE AQUÍ



Para la limpieza, nunca utilice productos abrasivos, utilice un paño suave y agua con jabón neutro para limpiar los muebles.