

# ASSEMBLY INSTRUCTION

## COUNTER HEIGHT / BAR HEIGHT CHAIR WITH METAL LEG

**A** Seat Cushion



1pc

**B** Back And Seat Frame



1pc

**C** Upper Leg Frame



1pc

**D** Lower Leg Frame



1pc

**E** Bottom Ring



1pc

**F** Swivel



1pc

**G** Allen Bolt  
1/4\*16mm



8pcs

**H** Allen Bolt  
1/4\*30mm



4pcs

**I** Screw  
4\*30mm



4pcs

**J** Flat Washer  
Dia.15\*1mm



12pcs

**K** Spring Washer  
Dia.10\*1mm



12pcs

**L** Allen Key  
4mm



1pc

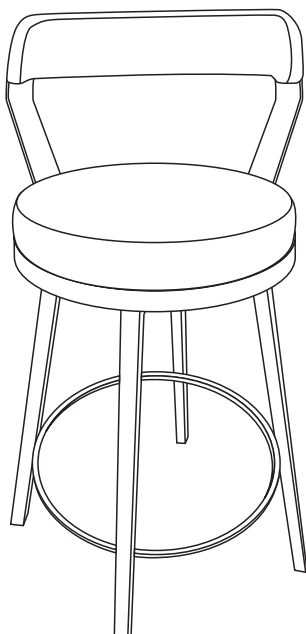

This page lists all the contents included in the box. Please take the time to identify the hardware as well as the individual components to this product. As you unpack and prepare for assembly, place the contents on a carpeted or padded area to protect them from damage.

**1** PUT UPPER LEG FRAME (C) TO LOWER LEG FRAME (D).

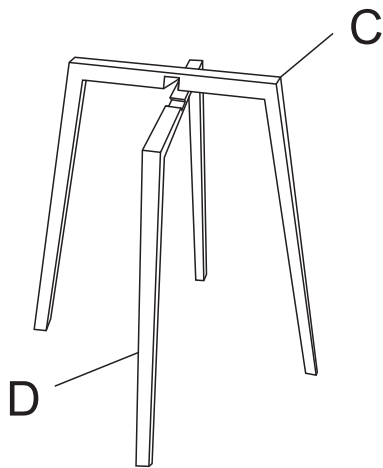

TAKE THE ALLEN WRENCH, AND TURN THE BOLTS UNTIL THE LEGS ARE SECURE. DO NOT TIGHTEN COMPLETELY. STOP WHEN YOU FEEL YOU ARE ADDING FORCE TO TIGHTEN THE BOLT.

**2** ATTACHED SWIVEL (F) TO UPPER LEG FRAME (C), USE ALLEN BOLT (G) THROUGH FLAT WASHER (J) AND SPRING WASHER (K) ON HOLES OF SWIVEL (F), TURN THE ALLEN KEY (L) IN ALLEN BOLT (G). ATTACHED BOTTOM RING (E) TO UPPER LEG FRAME (C) AND LOWER LEG FRAME (D), USE ALLEN BOLT (H) THROUGH FLAT WASHER (J) AND SPRING WASHER (K) ON HOLES OF BOTTOM RING (E), TURN THE ALLEN KEY (L) IN ALLEN BOLT (H).

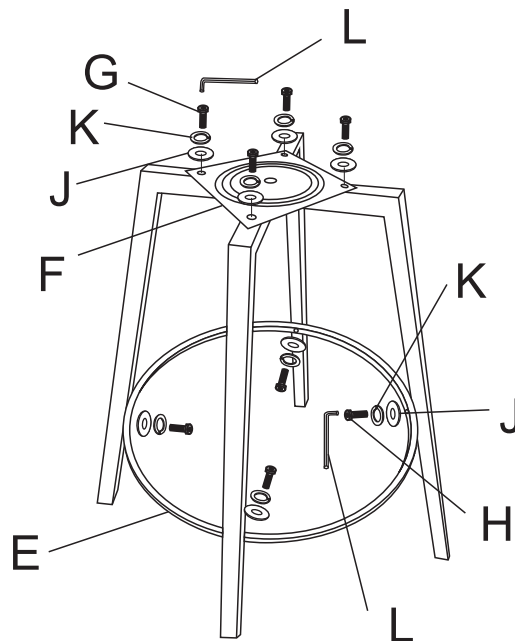

**3** ATTACHED SEAT CUSHION (A) TO BACK AND SEAT FRAME (B), TURN SCREW (I) IN HOLES OF BACK AND SEAT FRAME (B).

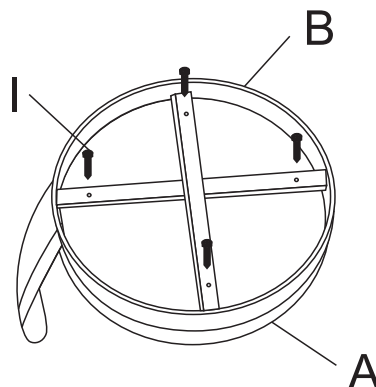

**4**

PUT SWIVEL (F) TO BACK AND SEAT FRAME (B), USE ALLEN BOLT (G) THROUGH FLAT WASHER (J) AND SPRING WASHER (K) ON HOLES OF BACK AND SEAT FRAME (B), TURN THE ALLEN KEY (L) IN ALLEN BOLT (G).

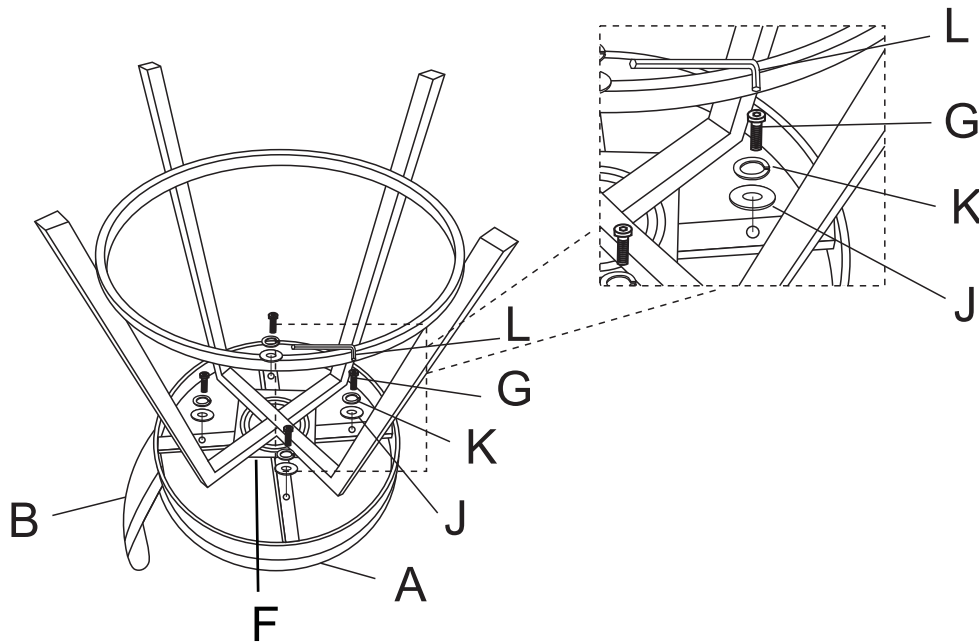

Stand chair up on an even surface and check that it is balanced.  
 If there is a slight wobble, apply downward pressure in the corner where a leg is uneven. Keeping pressure in that corner, tighten all bolts.  
 If balanced, apply downward pressure evenly in the center and tighten all bolts.  
 Do not over-tighten beyond hole depth.

Helpful Tip:  
 -Instead of applying downward pressure while reaching under to tighten bolts, have someone sit in the chair while you tighten the bolts.

### Cleaning & Care

Treat surface with care. Surface is resistant to scratches but is not scratch resistant. Clean surfaces with a dry or damp soft cloth. Do not use abrasive cleaners. Hardware may loosen over time.  
 Periodically check that all connections are tight.