

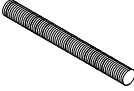









# HEKMAN®

A HOWARD MILLER COMPANY

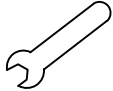
## 8-1219 SERVANT CONSOLE

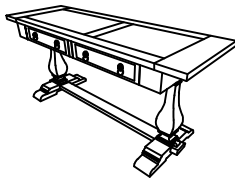
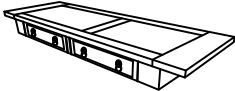
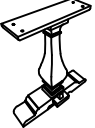
HARDWARE LIST									
A	B	C	D	E	F	G	H	I	J
BOLT M8 x 100 (2 PCS.)	HALF WASHER M8 (2 PCS.)	HEXAGON NUTS M8 (2 PCS.)	ALLEN BOLT M8 X 50 (8 PCS)	FLAT W. M8 (8 PCS.)	LOCK W. M8 (8 PCS.)	ALLEN KEY L5 (FOR ALLEN BOLT) (1 PC.)	WRENCH (FOR HEXA BOLT) (1 PC.)	LION HANDLE (FOR DRAWER) (4 PCS.)	BOLT M4 x 30 mm (FOR LION HANDLE) (4 PCS.)
									

PART INSIDE			
<b>1</b> TOP ASSEMBLY (1 Pc)	<b>2</b> LEG ASSEMBLY (2 Pcs)	<b>3</b> STRETCHER (1 Pc)	
			

### Assembly Instruction

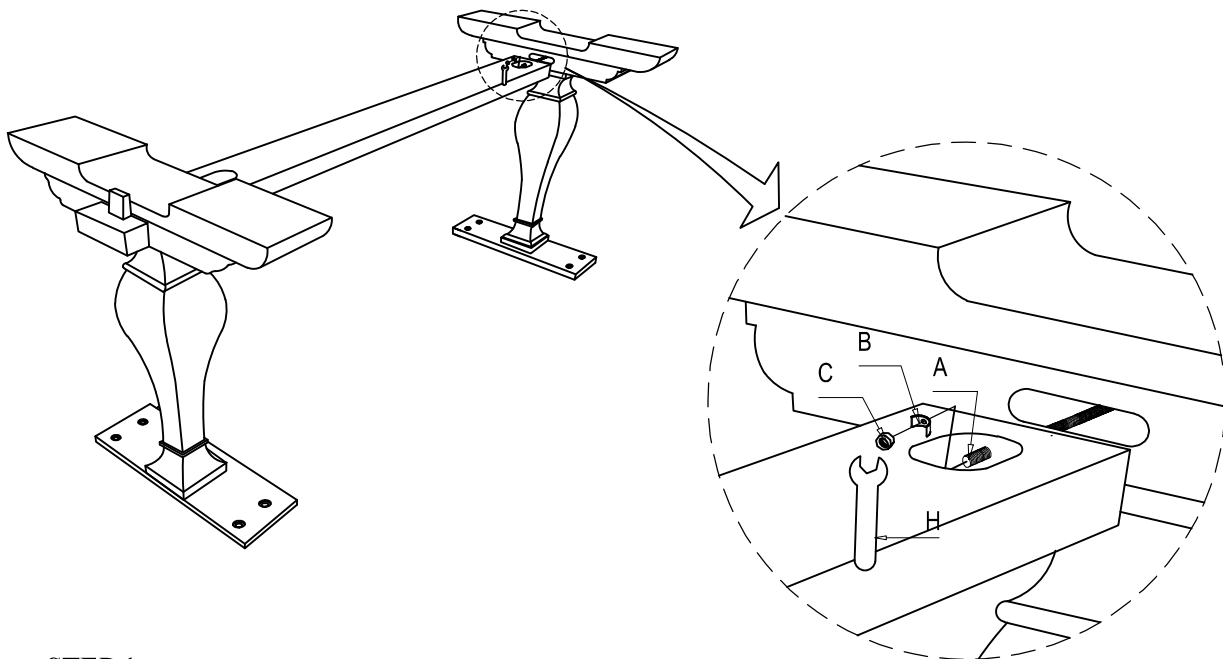

**STEP 1:**

INSERT THREADED ROD (A) INTO INSERT IN LEG ASSEMBLIES (2).  
PLACE STRETCHER (3) IN POSITION AND LOCK WITH HALFMOON WASHER (B), HEXAGON NUTS (C) USING WRENCH (I) PROVIDED.

**STEP 2.**

LAY TOP ASSEMBLY (1) UPSIDE DOWN ON A SOFT, CLEAN AND FLAT SURFACE. ALIGN THE HOLES IN THE TOP PLATE OF THE LEG ASSEMBLIES WITH THE INSERT IN THE BOTTOM PANEL OF THE TOP ASSEMBLY. CONNECT USING FLAT WASHER (E), LOCK WASHER (F), ALLEN BOLT (D) AND ALLEN KEY (G) PROVIDED.

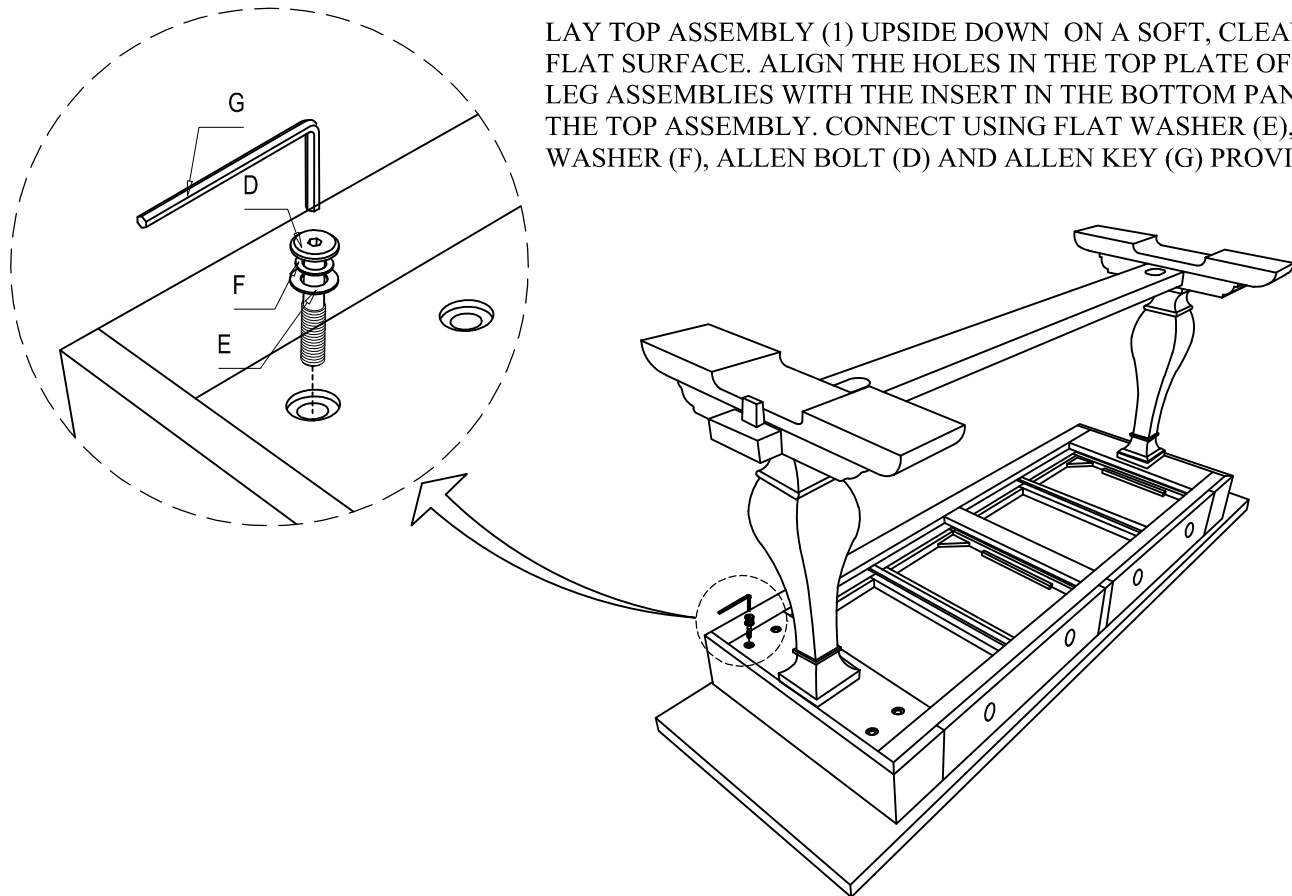

**STEP 3.**

THE KNOBS ARE ATTACHED WHEN THE ITEM IS DELIVERED.

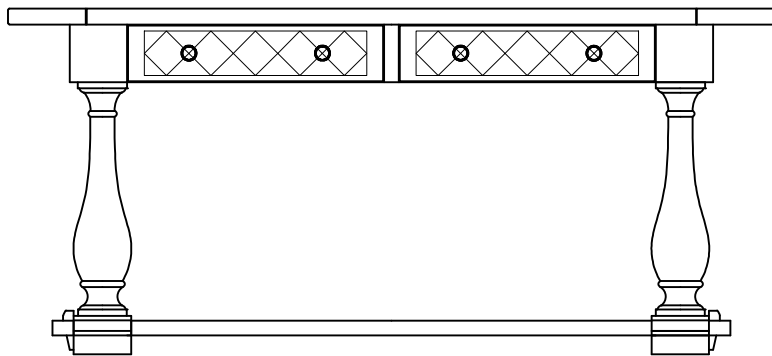

**STEP 4.**

THE COSTEMER CAN CHANGE THE KNOBS WITH LION HANDLE.

