

HEKMAN®

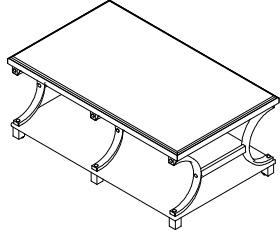

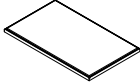
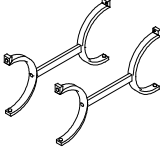
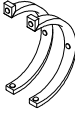
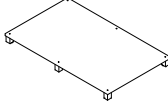

A HOWARD MILLER COMPANY

24800 RECTANGULAR COFFEE TABLE

Part List

1	2	3	4	
TOP PANEL 1 Pc	METAL LEG 2 Pcs	METAL LEG CENTER 2 Pcs	SHELF PANEL 1 Pc	
				

Hardware list

A	B	C	D	E
BOLT M6 x 40 6 PCS.	BOLT M6 x 80 6 PCS.	SPRING W. M6X13 12 PCS.	PLATE WASHER M6 X16 (12 PCS.)	ALLEN KEY L4 (FOR ALLEN BOLT) 1 PC.
				

STEP 1

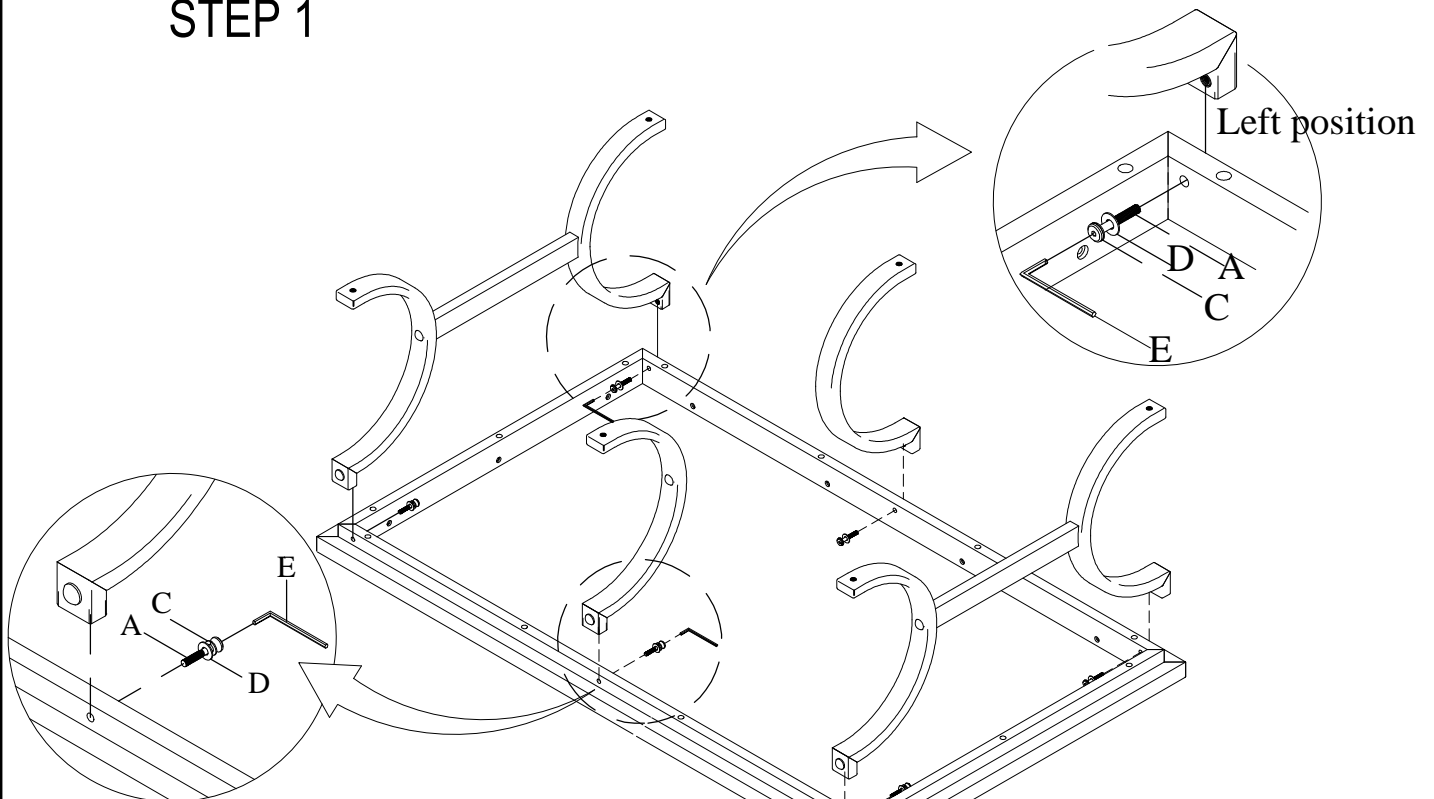

Join all metal legs to top with JCBC BOLT
M6 x 40 Mm (see detail) and do not tighten completely.
Tighten after shelf has been attached.

HEKMAN®

A HOWARD MILLER COMPANY

24800 RECTANGULAR COFFEE TABLE

STEP 2

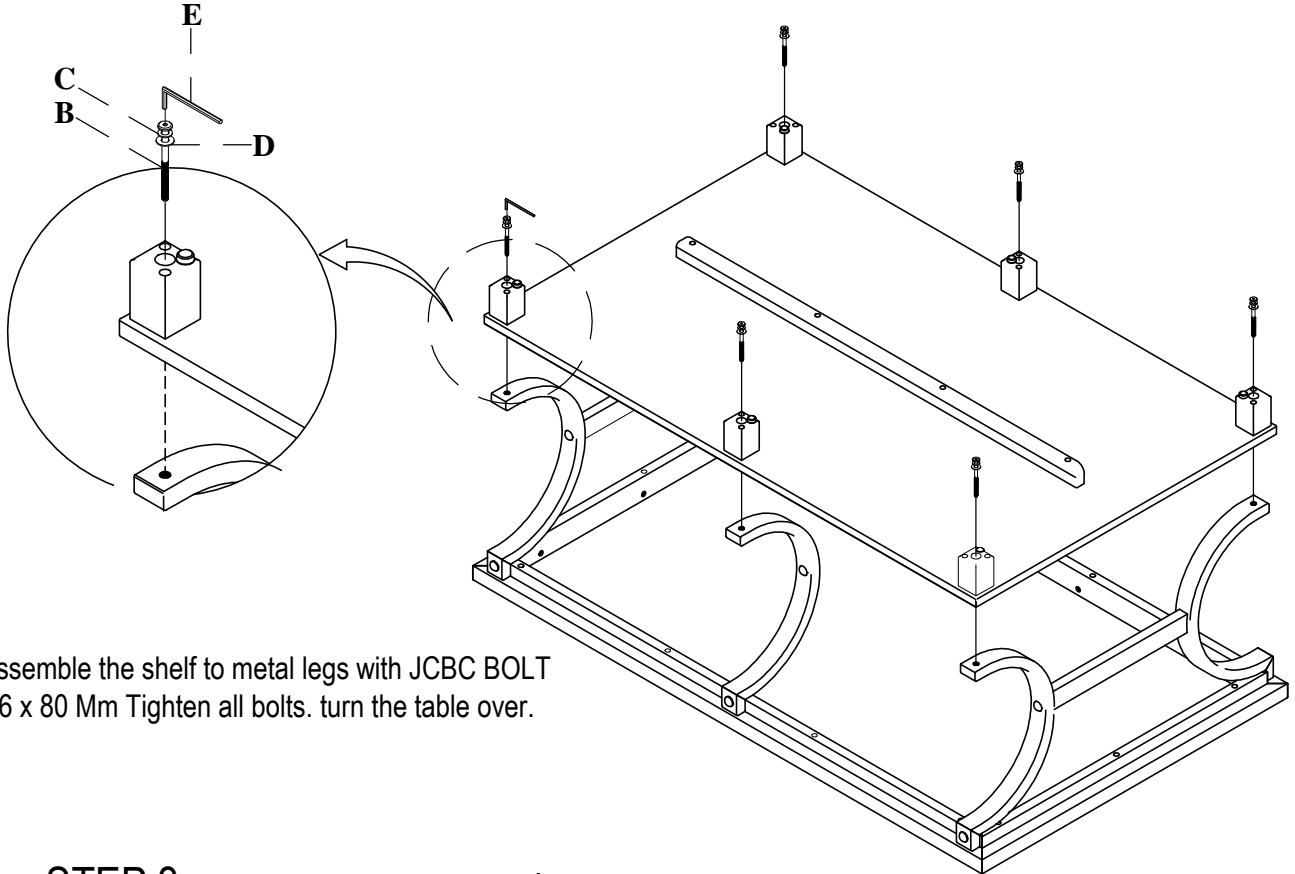

Assemble the shelf to metal legs with JCBC BOLT
M6 x 80 Mm Tighten all bolts. turn the table over.

STEP 3

