

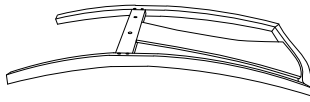

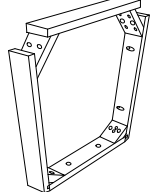



ASSEMBLY INSTRUCTION

DINING CHAIR

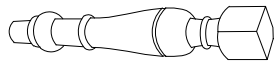
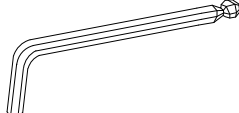
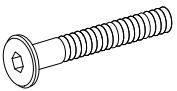
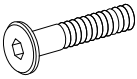
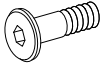
A Chair Back 	B Seat Frame 	C Seat Cushion 	D Front Leg 
1 PC E Allen Wrench M4 x 100mm 	1 PC F JCBC Bolt M6 x 70mm 	1 PC G JCBC Bolt M6 x 60mm 	2 PCS H JCBC Bolt M6 x 40mm 
1 PC I Lock Washer M6 	4 PCS J Flat Washer M6 	4 PCS K CSK Screw M4 x 25mm 	2 PCS
10 PCS	10 PCS	5 PCS	

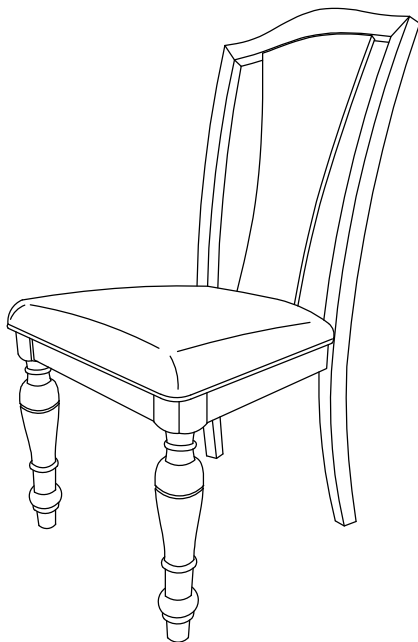

This page lists all the contents included in the box. Please take the time to identify the hardware as well as the individual components to this product. As you unpack and prepare for assembly, place the contents on a carpeted or padded area to protect them from damage.

1 Place Chair Back (A) upside down on a soft surface and attach Seat Frame (B).

(i) Insert JCBC Bolt (F), Lock Washer (I) and Flat Washer (J) into the corner holes and tighten with Allen Wrench (E).

(ii) Then, insert JCBC Bolt (H), Lock Washer (I) and Flat Washer (J) into the middle holes and tighten with Allen Wrench (E).

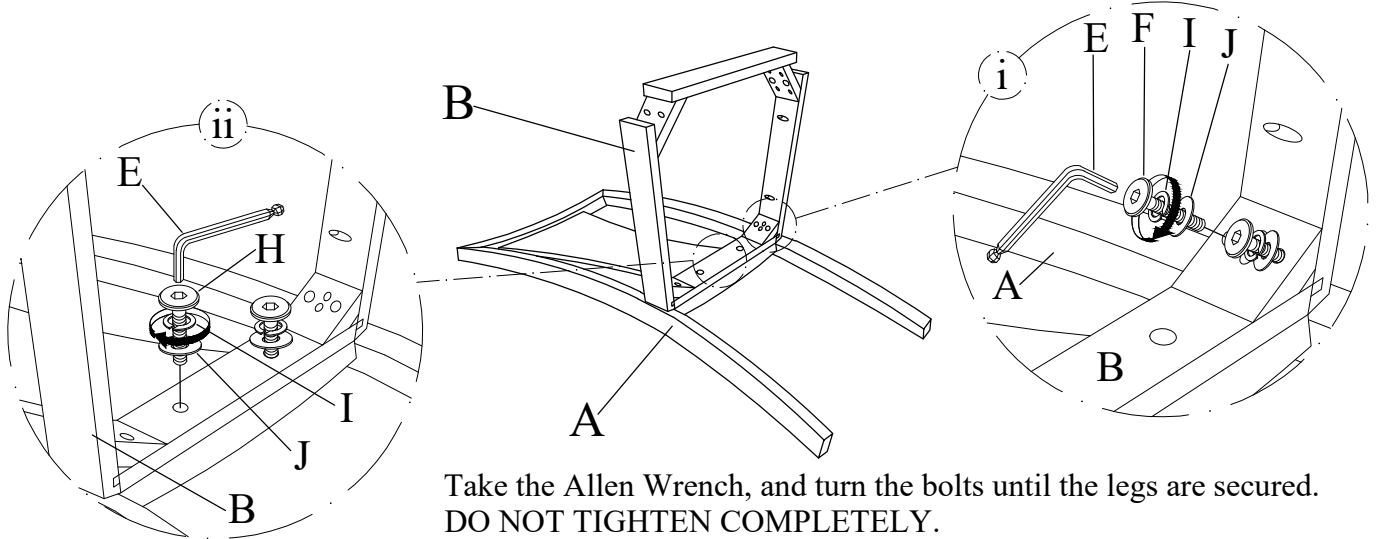

Take the Allen Wrench, and turn the bolts until the legs are secured.
DO NOT TIGHTEN COMPLETELY.
Stop when you feel you are adding force to tighten the bolt.

2 Attach Front Leg (D) to the corner of Seat Frame (B) by inserting JCBC Bolt (G), Lock Washer (I) and Flat Washer (J) and tighten with Allen Wrench (E).

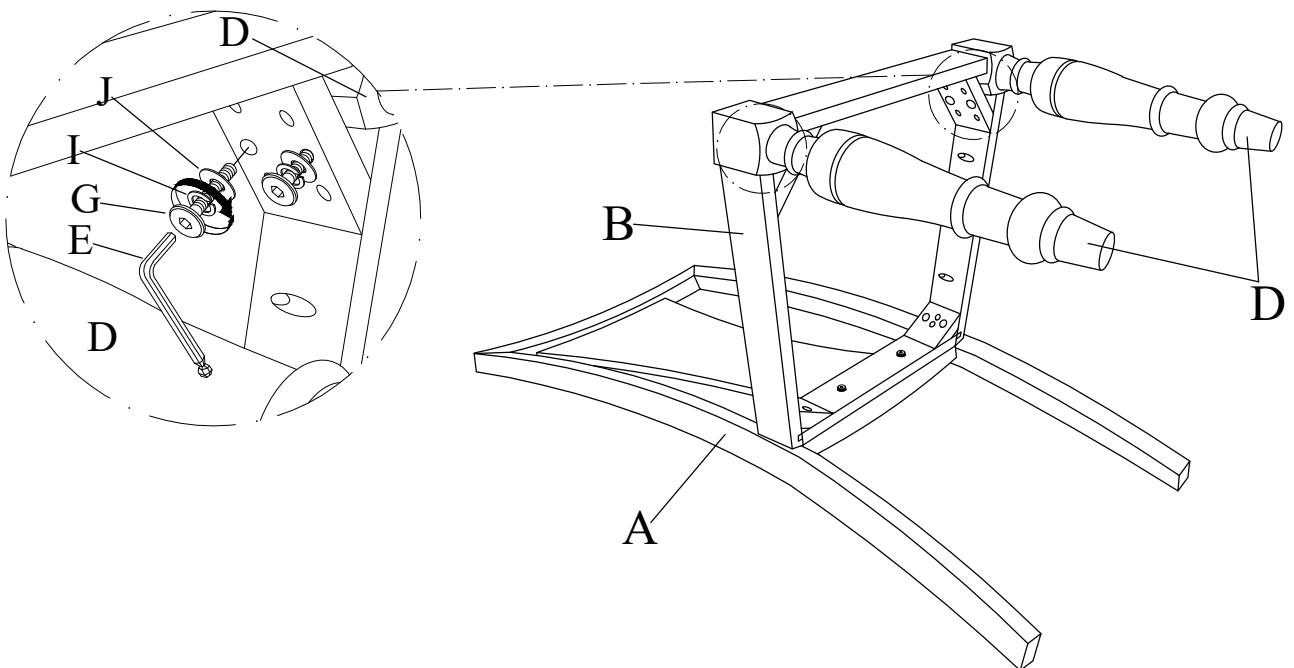

Take the Allen Wrench, and turn the bolts until the legs are secured.
DO NOT TIGHTEN COMPLETELY.
Stop when you feel you are adding force to tighten the bolt.

-
- 3** Attach Seat Cushion (C) to Seat Frame (B) by inserting CSK Screw (K) and tighten with screwdriver (not provided).

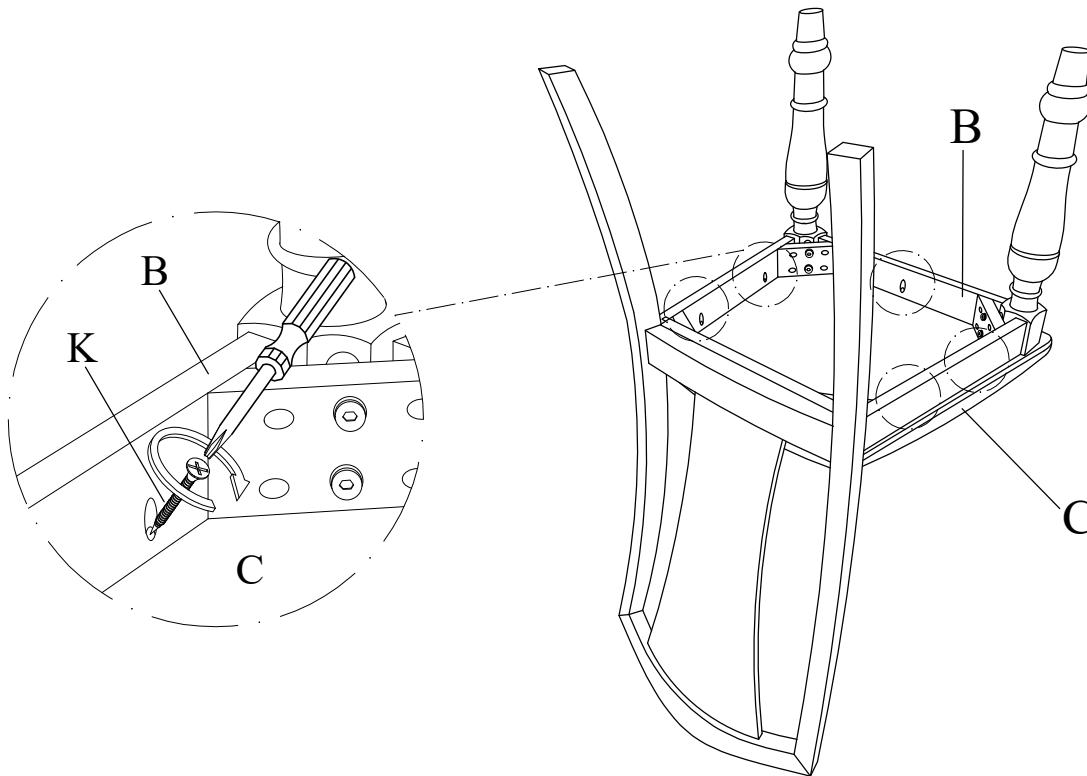

-
- 4** Stand chair up on an even surface and check that it is balanced. If there is a slight wobble, apply downward pressure in the corner where a leg is uneven. Keeping pressure in that corner, tighten all bolts. If balanced, apply downward pressure evenly in the center and tighten all bolts. Do not over-tighten beyond hole depth.

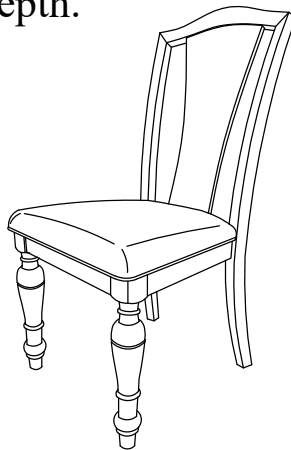

Helpful Tip : Instead of applying downward pressure while reaching under to tighten bolts, have someone sit on the chair while you tighten the bolts.

Cleaning & Care

Treat surfaces with care. Surface is resistant to scratches but is not scratch resistant. Clean surfaces with a dry or damp soft cloth. Do not use abrasive cleaners. Hardware may loosen over time. Periodically check that all connections are tight.