

Features

UN Rating: 3H1/Y1.8/100
Nominal capacity: 5.3 USG / 20.0L
Maximum capacity: 5.65 USG / 21.4 L
Tare weights: 2.73 lbs / 1.24 kgs

Colors

Standard: White, Black, Blue and Natural
Custom: Available at manufacturer's discretion

Decorating Options

Maximum Label Area:
Perimeter: 38-1/4" x 8-11/16" H
See Salesperson for Options

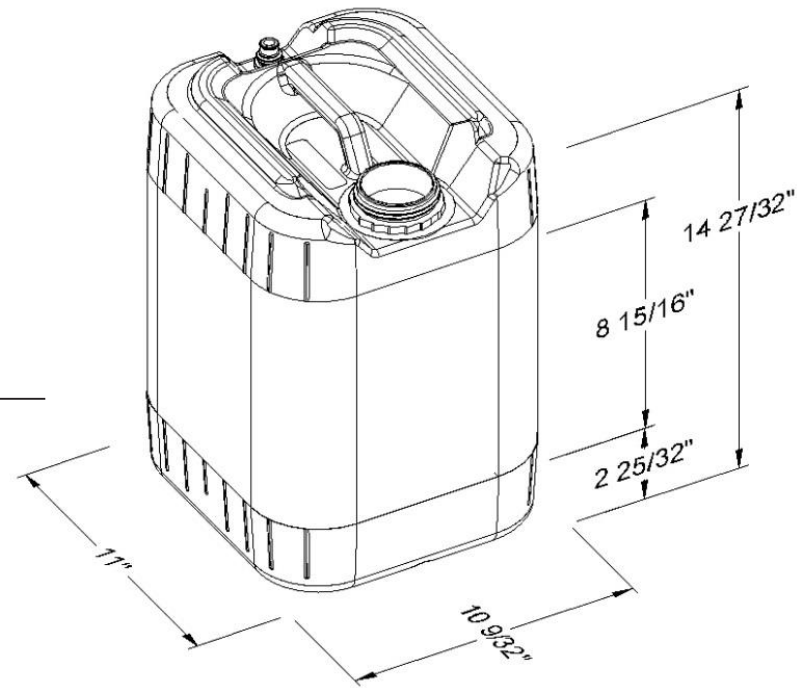

Shipping Data

Qty. per floor spot:	112
Gross Weight (lbs./kgs)*:	306 / 139
Length (in./cm.):	44 / 112
Width (in./cm.):	33 / 84
Height (in./cm.):	107 / 273

Containers

Estimated truckload quantity of 3,360 containers**

Notes: *Weight does not include pallet / packaging
**Truckload quantity based on 53' trailer

Materials

FDA approved materials
Resin: Body: High-Density Polyethylene (HDPE)

Optional Carrying Handle

Integral

DISCLAIMER

THIS INFORMATION IS PROVIDED AS A GENERAL GUIDE, INCLUDING DIMENSIONS. IT IS THE CUSTOMER'S RESPONSIBILITIES TO SELECT THE PROPER CONTAINER FOR PRODUCT AND APPLICATION COMPATIBILITY.

DISTRIBUTED BY:



REF NO.:



DWG30406

DESCRIPTION:

20 Liter HDPE Square TH Pail with Integrated Handle

REV. & DATE: A - DAY 4/7/2022

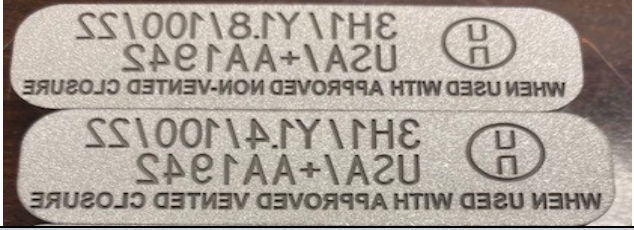
APPROVED BY:

PART SPECS				
SIZE:	20 Liter	NECK FINISH:	70 MM, 6 TPI ,TE Screw Cap	
WEIGHT:	1275g +/- 25g	PHOTO:	Photo may not be representative of actual color	
VENT FINISH:	Closed Vent 21 MM, TE			
RESIN:	0610205, Chevron 50100, VIRGIN 10 MI			
COLOR:	Natural			
ADDITIVE:	NA			
FOOD GRADE:	Yes			
UN TAGS:	3H1/Y1.8/100/XX/USA/+AA1942 and Y1.4			
CAP INSTRUCTIONS				
DUST CAP/CAP:	0910051, DUST CAP 70MM - NPC	VENT CAP/PLUG:	0911943 White TE Vent Cap 21 MM	
Face the dustcover tabs toward the handle, Torque Vent Cap to 30 in-lbs				
SLEEVES/LABELS:	NA	NA		
PACKING INSTRUCTIONS				
TRAYS:	0711172, CORR TRAY SST TH 46 X 41	STRETCH WRAP:		YES, 1510115
PIECES PER BUNDLE:	112	BANDING:	3 x 4 Banding Straps, 1510154	
PALLET:	1410123 - 48 x 40 #1 4 Way			
PALLET TAG/LABELS:	One pallet label per tray.			

SPECIAL INSTRUCTIONS / CUSTOMER SPECIFIC PHOTOS

All spouts must face each other, not exposed to outside of pallet.

Sidewalls must be flat. No spots of contamination larger than a pencil point (•) allowed. MAX 5 pencil-point size spots. No loose particulate, debris or grease allowed on the outside or inside of the container

<p align="center"><u>DISCLAIMER</u></p> <p>THIS INFORMATION IS PROVIDED AS A GENERAL GUIDE, INCLUDING DIMENSIONS. IT IS THE CUSTOMER'S RESPONSIBILITIES TO SELECT THE PROPER CONTAINER FOR PRODUCT AND APPLICATION COMPATIBILITY.</p>	<p>DISTRIBUTED BY: </p>	REF NO.:
	<p>DESCRIPTION:</p> <p align="center">20 Liter HDPE Square TH Pail with Integrated Handle</p>	

DWG30406