

Reorder Nos. **10443**  
**10444**

 Manufactured for:  
Dynarex Corporation  
10 Glenshaw Street  
Orangeburg, NY 10962  
USA • [www.dynarex.com](http://www.dynarex.com)  
Made in China



# ***DynaRest™***

## ***Airfloat Deluxe***

***Air Mattress with Digital Pump***



IP21



# USER MANUAL

## **INTRODUCTION**

Thank you for purchasing the DynaRest™ AirFloat Deluxe Air Mattress with Pump. This user's manual provides instructions on how to correctly use the product and gives valuable advice regarding your safety. Please read through the manual carefully before using the product. Should you have any questions, please contact your dealer for advice and assistance.

## **WARNINGS**

Keep this manual in a safe place and refer to the manual before use and under proper medical supervision. Improper operation of this system may cause damage to the product and possible injury to the user.

- Do not use this product or any available optional equipment without first completely reading and understanding this instruction manual. If you are unable to understand the warnings, cautions or instructions, please contact a healthcare professional, dealer or authorized technician before attempting to use this equipment, otherwise injury or damage may occur.
- Only qualified personnel trained in the treatment and prevention of bedsores should operate this device.
- Attention has to be paid to a potential danger that requires correct procedures or practices in order to prevent personal injury.
- Close supervision is necessary when this product is used by, on, or near children or persons with a disability.
- Keep the unit and cord away from heat sources and liquids.
- Never block the air openings of the product or place it on a soft surface, such as a bed or couch, where the air openings may be blocked. Keep the air openings free of lint, hair and the like.
- Do not use outdoors or operate where aerosol (spray) products are being used.

## **INTENDED USE**

The DynaRest™ AirFloat Deluxe Air Mattress is designed for bed sore and wound care therapy treatment and prevention, which may occur during an extended hospital stay and nursing home/long term care environment.

- Never drop or insert any object into any opening or hose.
- Do not remove the housing of the Control Unit to avoid electrical shock. All disassembly or repair should be done by professional technicians.
- Never operate this product if it has a damaged cord or plug, if it is not working properly, if it has been dropped or damaged, or dropped into water. Return the product to a service center for examination or repair.
- Connect this product to a properly grounded outlet only.
- Make sure the pump unit is suitable for the local power voltage.
- Avoid damaging the plug or cables when moving the patient or bed.
- Ensure that the cables are safe and tidy and not caught in the bed mechanism or resting on the floor.
- Do not allow children to play with or operate the pump or mattress.
- Do not use this product for any purpose other than what is indicated in this manual.
- Dynarex declines all liability for any consequences resulting from incorrect use of this product and from any unauthorized alterations of this product.
- The manufacturer reserves the right to change the information contained in this document without prior notice.

## GENERAL DESCRIPTION

### Pump Controls and Features



### Main Control Panel

#### 1 POWER SWITCH



When LED is illuminated the power is on.

#### 2 CYCLE TIME



Pushing the button adjusts the cycle time from 10, 15, 20 and 25 minutes for "Alternating" cell function.

#### 3 THERAPY/AUTO FIRM



- ALTERNATING: Normal alternating function.
- STATIC: Does not alternate & keeps all mattress cells always inflated.
- MAXFIRM: Quickly inflates mattress to maximum firmness.
- SEAT INFLATE: Provides extra support when the patient is in a seated position.

#### 4 WEIGHT SETTING

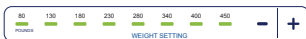

To increase or decrease airflow for a softer or firmer mattress setting the numbers denote suggested setting based on patient weight.

#### 5 WARNINGS



- LOW PRESSURE: Light will illuminate and alarm sounds when the pressure is below the preset level.
- POWER FAILURE: There is no power to the unit.
- ALTERNATING FAILURE: There is an error with the alternating function.
- MUTE: Mutes the audible alarm for 20 minutes.

#### 6 PANEL LOCK



The unit locks all functions\* automatically after five minutes. To unlock the unit, press and hold the button for three seconds.

\*"Power" and "Mute" function do not lock.

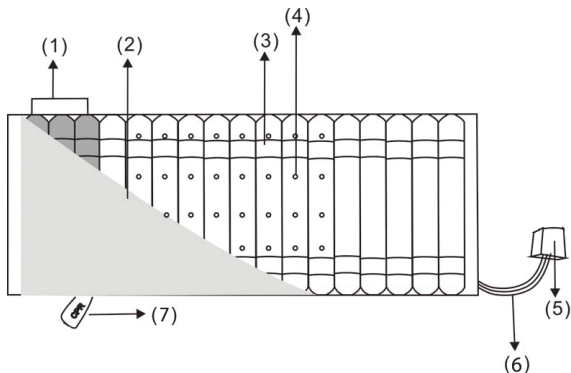

- (1) Pillow Section - does not alternate
- (2) Cover
- (3) Fixing belt
- (4) Low air loss holes
- (5) Male quick connector
- (6) Air tubing
- (7) CPR Valve

## **CELL-ON-CELL FEATURE**

The mattress is an 8" cell-on-cell type mattress which prevents bottoming out in case of a sudden power outage. The mattress will temporarily retain air even when the pump is turned off or during a power outage.

Please note this is only temporary.

The cover sheet protects the cells against unexpected contamination, and makes cleaning of the mattress easier.

## INSTALLATION

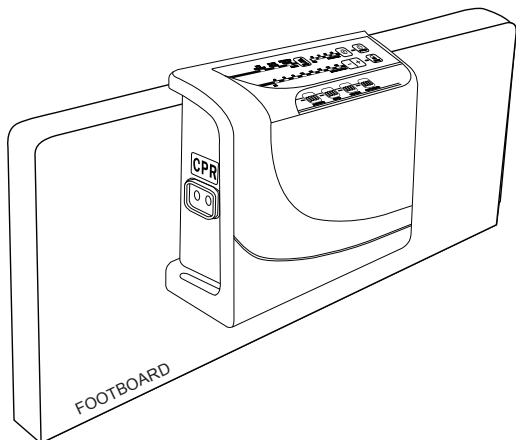

1. This is a replacement mattress. Place the mattress directly on the bed frame, with the air hose connectors positioned at the footboard.
2. Hang the pump onto the bed board (footboard side) using the hooks on back of the pump, or place it on a flat surface.
3. Connect air hose connectors from air mattress to the pump unit. Ensure the air hoses are not kinked or tucked under the mattress.
4. Plug the power cord into the electrical outlet.
5. Turn the power ON.

## STORAGE

1. Switch off power from main and unplug, separate the pump from the mattress and place the mattress flat.
2. Fold the mattress in two from mattress foot to head.
3. Allow time for air to escape from mattress to reduce storage space.
4. Close the protective cap cover on the quick connector.

## SPARE PARTS/ACCESSORIES

For spare parts and accessories please contact Dynarex or an authorized dealer.

## GENERAL CONDITIONS OF DISPOSAL

Dispose of the device in the appropriate disposal areas for recycling.

At the end of its life, the product must not be disposed of along with other domestic waste. Dispose of this equipment by bringing it to a specific recycling point for electric and electronic equipment or others that provide this service.

## TROUBLESHOOTING

If your questions can't be answered with below information, please contact your local agent directly. They might require a technician to take care of the problem.

No lights on unit	<p>Check control unit is connected to the main power supply and that the unit is switched on.</p> <p>Check quick blow fuse on the control unit or mains plug fuse.</p>
Low pressure alert	<p>Check main power to the control unit and that the plug is switched.</p> <p>Check mattress air supply connector is connected to the pump unit correctly.</p> <p>Check CPR connector is connected properly.</p> <p>Under the mattress cover check all "T" &amp; "L" connectors are connected to the air tubes.</p> <p>Check the connector tubes for kinks, crimps or damage.</p>
Patient's body is sagging in the middle/bottoming out	<p>Increase the value of the comfort setting. Wait a couple of minutes so pressure can stabilize before making another change.</p>
Control lock up or "freeze"	<p>Turn the control unit off and unplug the pump. Wait a few minutes and plug the control unit back in. Turn on the control unit.</p>

## MAINTENANCE

In case of repair, use only original spare parts and accessories.

## CLEANING AND DISINFECTION



### WARNING!

Unplug the pump before starting the cleaning procedure.

1. Clean the mattress with mild soap.
2. Do not immerse or soak pump unit.
3. After cleaning, dry the mattress without direct sunlight exposure.
4. Check that the connection tubes are not obstructed by dust or other object. Use a soft swab to clean the tubes if necessary.

### NOTE:

Never use acids, alkalis or solvents such as acetone to clean the mattress.

## TECHNICAL FEATURES

### Pump Control Unit

FEATURE	PUMP
Power supply	120 V/60 Hz
Power	15.5 W
Fuse rating	1A/250 V
Pressure	20 mmhg~60 mmhg
Dimensions	12½" (W) × 12" (L) × 6" (H)
Cycle	10/15/20/25 mins
Environment Temperature	Operation: 10°C-40°C Storage: 10°C-40°C Shipping: 10°C-40°C
Environment Humidity	Operation: 15%-90% Storage: 15%-90% non-condensing Shipping: 15%-90% non-condensing
Atmospheric Pressure	Operation: 700-1013, 25 hPa

### Mattress

FEATURE	MATTRESS
Dimensions	10443-80" (L) × 36" (W) × 8" (H) 10444-80" (L) × 36" (W) × 8" + 3" perimeter (H)
Cell height (inflated)	8"
Air cell material	Nylon/TPU
Cover material	PU + Fiber Quilting
Elements number	20 cells
Max weight	450 lb.
Weight	25 lb.

## LIMITED LIFETIME WARRANTY

Your Dynarex Product is warranted to be free of defects in materials and workmanship for twenty-four (24) months from original date of purchase for the original purchaser. This item was built to exacting standards and carefully inspected prior to shipment. This Limited Lifetime Warranty is an expression of our confidence in the materials and workmanship of our products and our assurance to the consumer of years of dependable service.

The Warranty shall not apply under the following conditions:

- Problems arising from normal wear
  - Problems arising from failure to adhere to the product instructions
  - Problems arising from misuse, negligence, accident or improper operation, maintenance or storage
  - Problems arising from modifications or unauthorized repairs, parts or attachments
- Products where the serial number has been removed or defaced
  - Problems with non-durable components, such as rubber accessories, casters, and grips, which are subject to normal wear and need periodic replacement

Dynarex shall not be liable for any consequential or incidental damages whatsoever. Dynarex shall repair or replace defective products at its option. The foregoing warranty is exclusive and in lieu of other express warranties, if any, including the implied warranties of merchantability and fitness of a particular purpose. The remedy for any violation of the implied warranty shall be limited to repair or replacement of the defective product pursuant to the terms contained herein.

If you have a question about your Dynarex device or this warranty, please contact an authorized Dynarex dealer.



**SYMBOL GLOSSARY**  
For an explanation of symbols  
used in Dynarex packaging, visit  
[dynarex.com/symbols.php](http://dynarex.com/symbols.php)