

Product Specifications

2-Gallon Universal Round Container

Multiple Uses

Dry Products
Liquid Products

Product Codes

Container: **Ropak R2U Pail**
Description: 2-gallon round pail

Features

Gauge: 70 mil.
Nominal capacity: 2.0 USG / 7.6 L
Stack performance: 200 lbs.*
Tare weights: Body: .84 lbs. / .380 kgs**
Cover: .28 lbs. / .125 kgs.**

Note: *Ratings will be reduced with uneven load distribution.
**Tare weights do not include handles, fittings, or gaskets.

Specifications with Cover

Dimensions: 9-15/16"D X 9-7/8"H
Maximum capacity: 2.1 USG / 7.9 L
Tare weight: 1.12 lbs. / .510 kgs.

Colors

Standard: White, Black and Natural
Custom: Available at manufacturer's discretion

Decorating Options

Silk - Screening: 25-1/2"W X 5-3/4"H
Four or six* color offset printing
Print area: 27-1/2"W X 5-3/4"H
NXT Graphics®

Note: *Where available

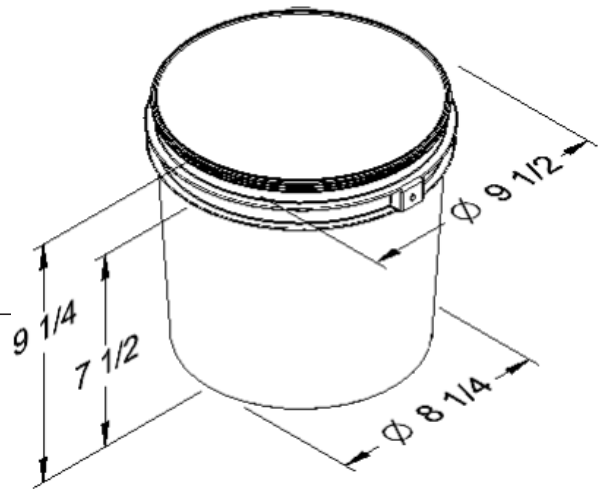

Projected Shipping Data

| | |
|-----------------------------|----------|
| Qty. per pallet: | 720 |
| Gross Weight: (lbs./kgs)**: | 590/267 |
| Length (in./cm.): | 49/125 |
| Width (in./cm.): | 39.5/100 |
| Height (in./cm.): | 88/223.5 |

Bodies

Filled Containers

100 (20 per layer / 5 layers high)
Pallet height: 51"

Estimated truckload quantity of 14,400 bodies and covers***

Notes: *Bulk pack also available
**Weight does not include pallet/packaging
***Truckload quantity based on 53' trailer

Materials

FDA approved materials
Resin: Body: High-Density Polyethylene (HDPE)

Optional Carrying Handles

DISCLAIMER

THIS INFORMATION IS PROVIDED AS A GENERAL GUIDE, INCLUDING DIMENSIONS. IT IS THE CUSTOMER'S RESPONSIBILITIES TO SELECT THE PROPER CONTAINER FOR PRODUCT AND APPLICATION COMPATIBILITY.

DISTRIBUTED BY:



REF NO.:

DWG31676

DESCRIPTION:

2 Gallon HDPE Open Head Pail, Ropak