

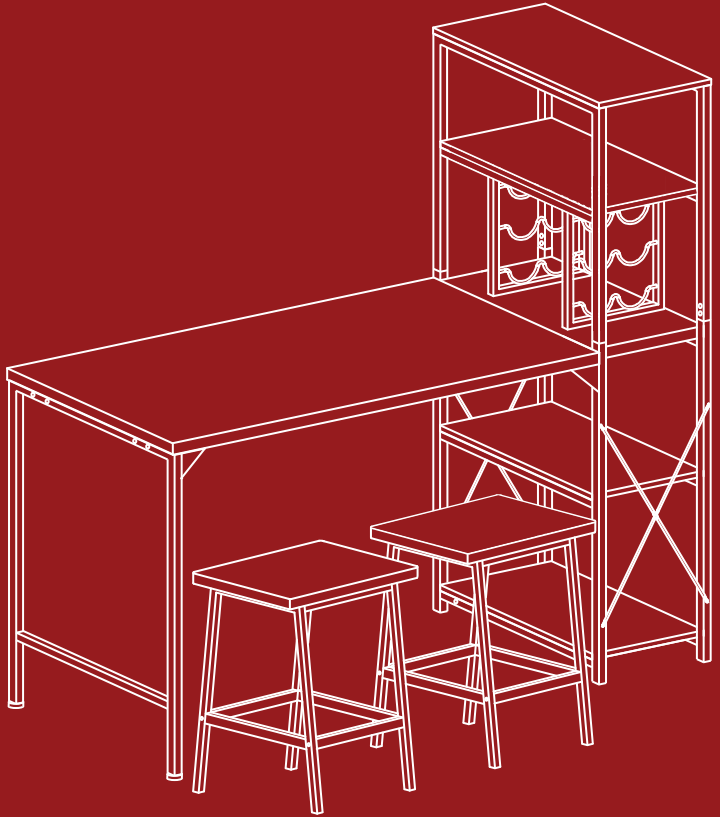

BEST CHOICE
PRODUCTS



INSTRUCTION MANUAL

Counter Height Home Bar Set

! NOTICE

Please retain these instructions for future reference.

NOTE: FASTEN SCREWS LOOSELY DURING INITIAL ASSEMBLY. DO NOT TIGHTEN SCREWS UNTIL ITEM IS COMPLETELY ASSEMBLED.

- Please do not exceed the weight limitations of this item.
- Do not stand on or use any part of this item as a step ladder.
- Firmly secure all bolts, screws, and knobs before use.
- Reconfirm that all bolts, screws, and knobs are secure every 90 days.
- Do not use or store this item in the proximity of open flame or flammable/combustible chemicals.
- If any parts are missing, broken, damaged, or worn, stop using this item until repairs are made and/or factory replacement parts are installed.
- Do not use this item in a way inconsistent with the manufacturer's instructions as this could void the product warranty.
- This product features two assembly options for the shelving section. Follow instructions carefully for best results.
- This product is intended for residential use only.

TOOLS REQUIRED



ALLEN WRENCH
(PROVIDED)



WRENCH
(PROVIDED)



TABLE
110 LBS
CAPACITY



SHELF
35 LBS
CAPACITY



STOOL
250 LBS
CAPACITY



2 PERSON
ASSEMBLY



UP TO 1 HOUR,
ASSEMBLY

HARDWARE

1

M6 X 45MM
SCREW



4 PCS

2

M6 X 30MM
SCREW



34 PCS

3

M6 X 12MM
SCREW



26 PCS

4

M6 X 22MM
SCREW



4 PCS

5

END NUT



2 PCS

6

FOOT PAD



2 PCS

7

M6 X 40MM
SCREW



24 PCS

PARTS

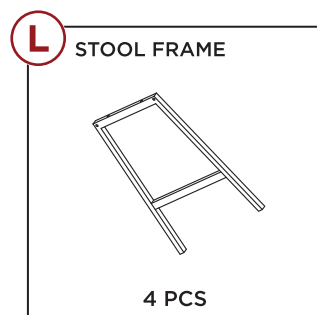
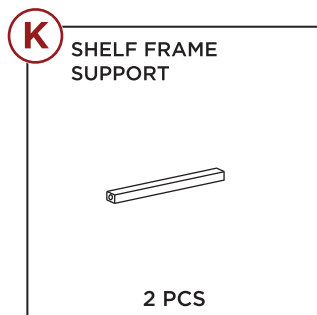
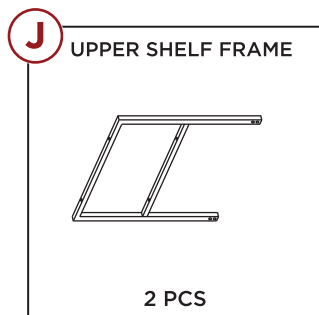
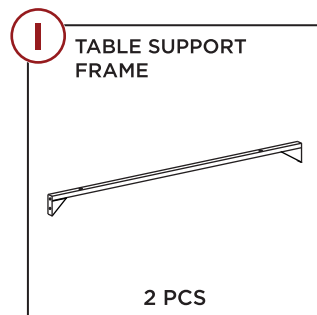
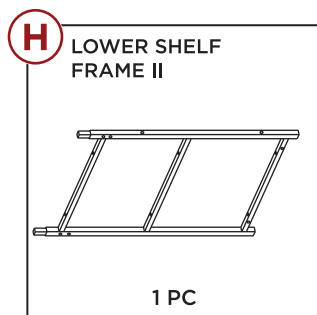
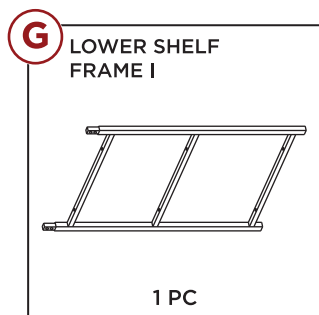
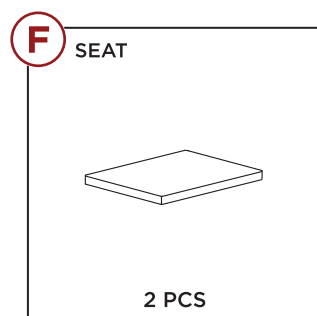
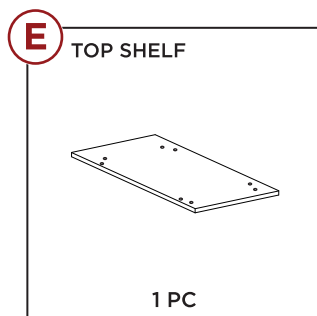
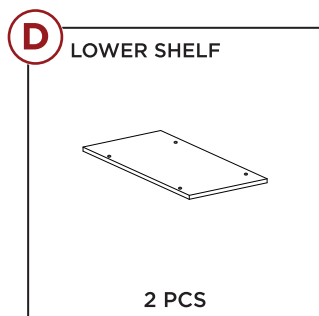
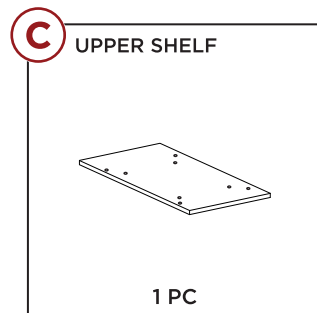
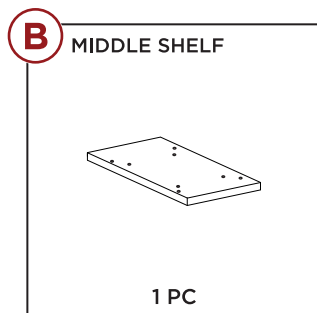
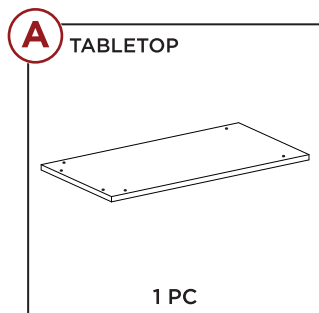

PARTS

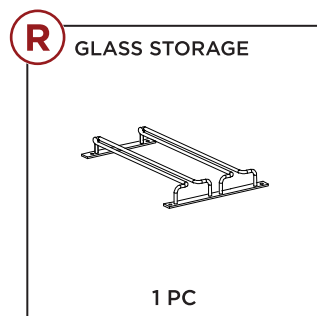
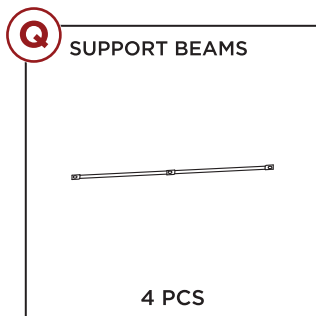
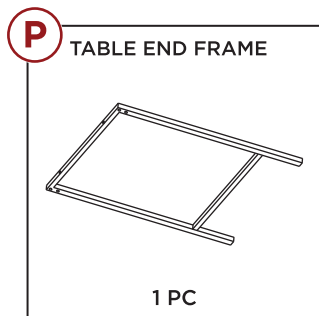
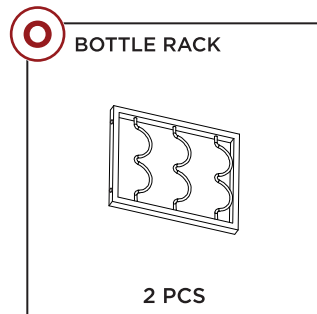
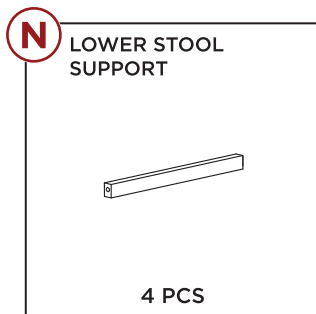
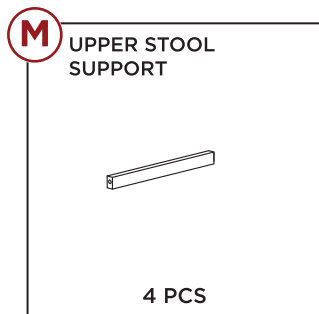

PRODUCT ASSEMBLY - Table

1

Attach the **part G** and **H** lower shelf frames to two **part K** shelf frame supports with **four part 2 screws**, two screws per shelf frame.

Attach two **part J** upper shelf frame with eight **part 3 screws**, four screws per shelf frame.

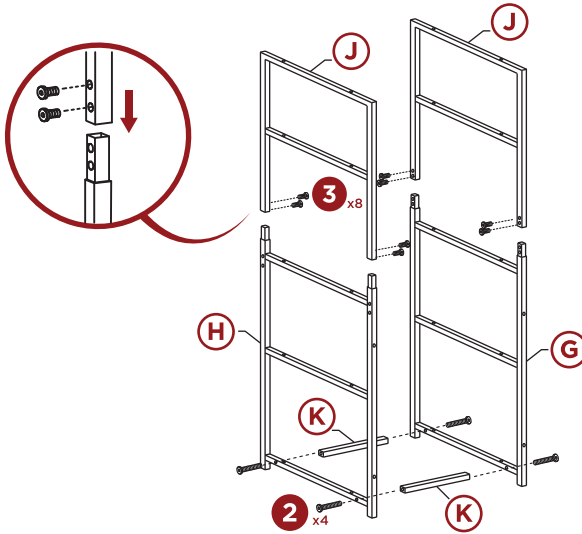

2

Attach one **part D** lower shelf to the bottom tier of the shelf frame assembly with four part 2 screws. Repeat to attach a second **part D** lower shelf to the next tier up.

Screw two **part 6** foot pads into the legs of the **part P** table end frame, then attach two part 1 table support frame with two part 2 screws and two part 3 screws.

Attach the open sides of the **part I** table support frame to the **part H** lower shelf frame II with two **part 2 screws** and two **part 3 screws**.

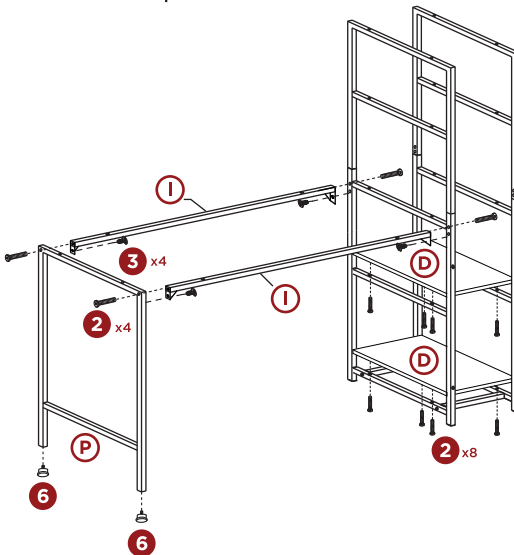

PRODUCT ASSEMBLY - Table

3

Attach the **part B middle shelf** and **part C upper shelf** to the **part J upper shelf frames** with eight **part 2 screws**, four screws per shelf.

Attach the **part R glass storage** to the **part E top shelf** with four **part 3 screws**, then attach it to the top of the **part J upper shelf frames** with four **part 2 screws**.

Overlap two **part Q support beams** to make an 'X' then secure them together with one **part 3 screw** and one **part 5 end nut**. Attach the crossbar assembly to the **part G and H lower shelf frames** with four **part 3 screws**.

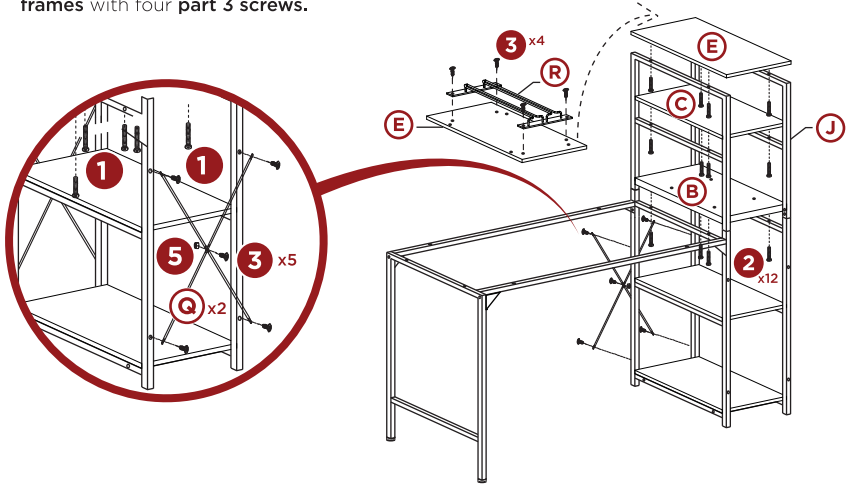

4

Overlap two **part Q support beams** to make an 'X' then secure them together with one **part 3 screw** and one **part 5 end nut**. Attach the crossbar assembly to the **part G and H lower shelf frames** with four **part 3 screws**.

Attach the **part A tabletop** to the **part I table support frames** with six **part 2 screws**.

Attach two **part O bottle racks** to the **part B middle shelf** with four **part 1 screws**, then secure the racks to the **part C upper shelf** with four **part 4 screws**.

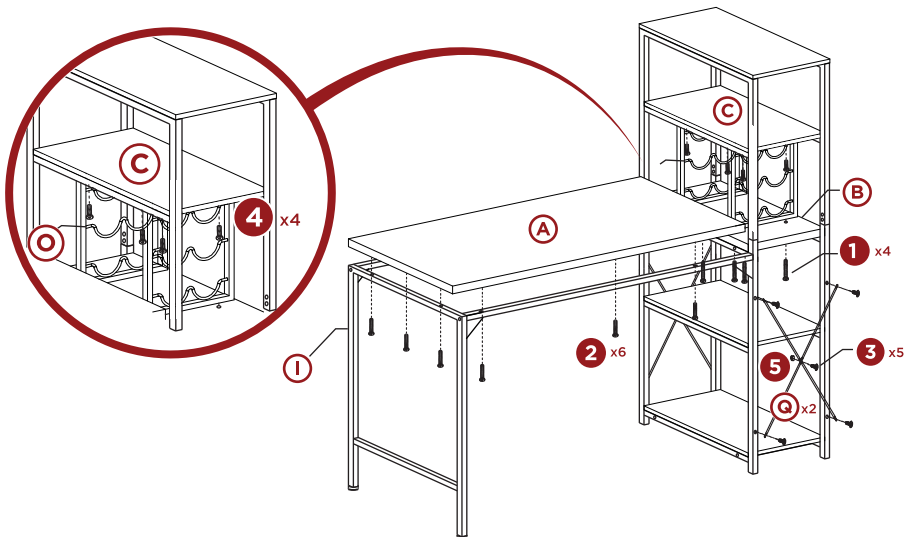

PRODUCT ASSEMBLY - Stool

1

Attach two **part L stool frames** to two **part N lower stool supports** with four **part 7 screws**, two screws per side.

Attach two **part M upper stool frames** to the **part L stool frames** with four **part 7 screws**, two screws per side.

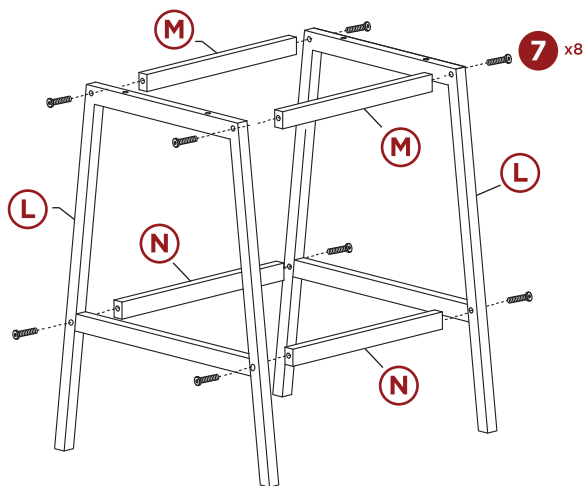

2

Attach the **part F seat** with four **part 7 screws**.

Repeat steps 1 & 2 of Product Assembly (Stool) to assemble a second stool.

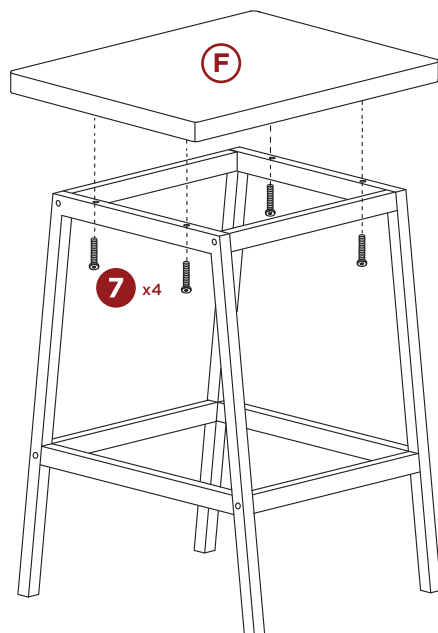



HELP CENTER



Question about your product? We're here to help. Visit us at:

help.bestchoiceproducts.com



Chat Support



Product Inquiry



Orders FAQ



Product Assembly



Returns & Refunds

PRODUCT WARRANTY INFORMATION

All items can be returned for any reason within 60 days of the receipt and will receive a full refund as long as the item is returned in its original product packaging and all accessories from its original shipment are included. All returned items will receive a full refund back to the original payment method. All returned items will not be charged a re-stocking fee.

All returned items require an RA (Return Authorization) number, which can only be provided by a Best Choice Products Customer Service Representative when the return request is submitted. Items received without an RA may not be accepted or may increase your return processing time. Once an item has been received by Best Choice Products, refunds or replacements will be processed within 5 business days.

All returns must be shipped back to the Best Choice Products Return Center at the customer's expense. If the reason for return is a result of an error by Best Choice Products then Best Choice Products will provide a pre-paid shipping label via email. Boxes for return shipping will not be provided by Best Choice Products, and is the customer's responsibility to either use the original shipping boxes or purchase new boxes.

Pictures may be required for some returns to ensure an item is not damaged prior to its return. Items returned are not considered undamaged until they are received by Best Choice Products and verified as such. All damages to items are the customer's responsibility until the item has been received by and acknowledge by Best Choice Products as undamaged.

© 2023 Best Choice Products, Inc. All rights reserved. Distributed by Best Choice Products, Inc. Tustin, CA 92780

WARNING

Manufacturer and seller expressly disclaim any and all liability for personal injury, property damage or loss, whether direct, indirect, or incidental, resulting from the incorrect attachment, improper use, inadequate maintenance, unapproved modification, or neglect of this product.