



Project Name: \_\_\_\_\_

Location: \_\_\_\_\_

Item #: \_\_\_\_\_

Qty: \_\_\_\_\_

## Adcraft Topping Warmer and Dispenser, Single Pump, in Stainless Steel

NCW1P120



Keep sauces and toppings warm, delicious, and ready to serve with the Adcraft Single Pump Topping Warmer and Dispenser. This single-pump commercial topping warmer and dispenser has a capacity of 3.5 quarts and is ideal for use with nacho cheese, hot fudge, caramel, chili, or dessert sauces. This versatile warmer and dispenser is a must-have for concession stands, quick-service restaurants, convenience stores, cafeterias, and other foodservice establishments. The unit features a heated stainless steel base with adjustable temperature control, allowing toppings to be kept at the perfect serving consistency.

### Features and Construction

- Constructed with durable stainless steel for longevity
- Operates on 120V with a NEMA 5-15 plug type
- Equipped with mechanical controls for precise operation
- Single pump dispenser with 3.5 quart capacity
- Features no casters for stable placement
- Designed to keep toppings at safe serving temperatures
- Dispenses toppings in controlled portions
- Overall maximum temperature of 195°F
- Perfect for nacho cheese, hot fudge, caramel, chili, gravy and more
- Also ideal for condiments including ketchup, mustard or specialty sauces

### Electric

120V ~ 60Hz - 550W (4.5)A  
Cord Length (Inches): 71  
Plug Type: NEMA 5-15P  
Cord set included

NEMA 5-15P



### 3rd Party Approvals



### Warranty (USA / Canada)

Protected by Admiral Craft Equipment Corporation's One-Year Limited Warranty

Contact Admiral Craft Equipment for details at 1-877-672-7740



### Capacity

- 3.5 Qt

### Included Components

- Warmer and pump



# Adcraft Topping Warmer and Dispenser, Single Pump, in Stainless Steel

NCW1P120

FRONT

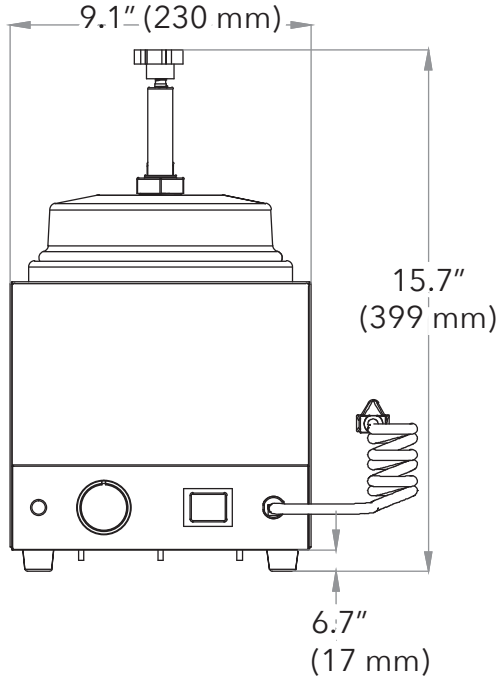

SIDE

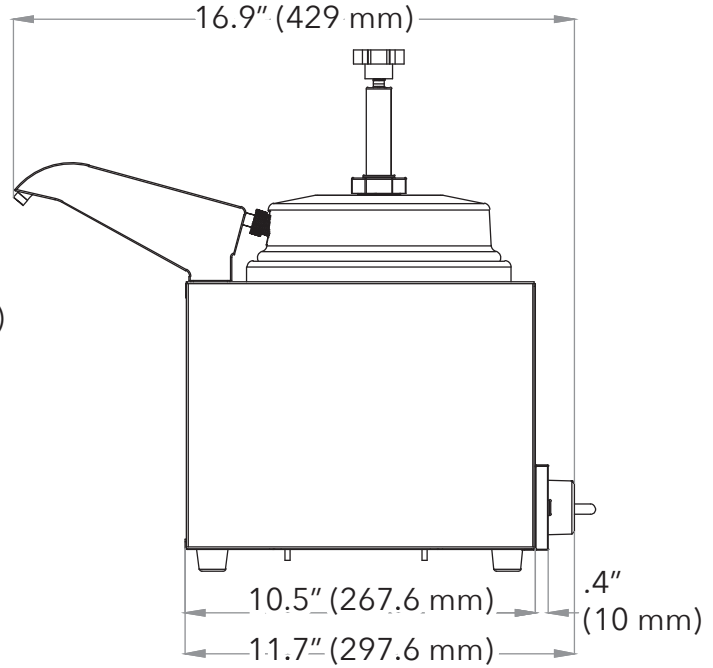

TOP

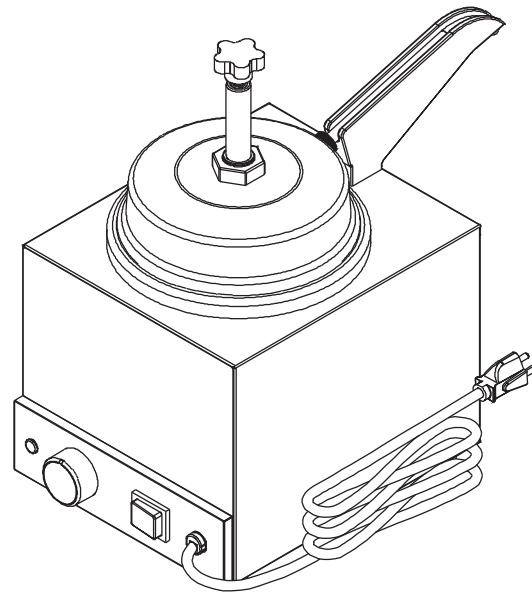
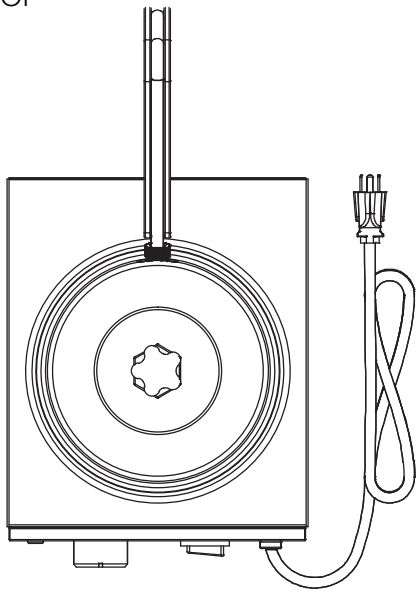

## Dispenser

Control Type	Capacity	Assembled Dimensions L x W x H (in)	Package Dimensions L x W x H (in)	Item Weight (lb)	Shipping Weight (lb)
Mechanical	3.5 Qt	15.71" x 9.10" x 16.90"	19.49" x 11.81" x 15.55"	8.0	10.1

Due to periodic changes in designs, methods, procedures, policies and regulations, the specifications contained in this document are subject to change without notice. While we exercise good faith efforts to provide information that is accurate, we are not responsible for errors or omissions in information provided or conclusions reached as a result of using the specifications. By using the information provided, the user assumes all risks in connection with such use.