



BEST CHOICE
PRODUCTS



INSTRUCTION MANUAL

3-Piece Oval Dining Set

SKY8101 + SKY8102 + SKY8103 + SKY8104 + SKY8105 + SKY8106
SKY8107 + SKY8108 + SKY8109

! NOTICE

Please retain these instructions for future reference.

- Please do not exceed the weight limitations of this item.
- Do not stand on or use any part of this item as a step ladder.
- Firmly secure all bolts, screws and knobs before use.
- Reconfirm that all bolts, screws, and knobs are secure every 90 days.
- Fasten screws loosely during assembly. Do not firmly tighten screws until item is fully assembled.
- Do not use or store this item in the proximity of open flame or flammable/combustible chemicals.
- Be aware that some parts are heavy and have sharp edges.
- If any parts are missing, broken, damaged, or worn, stop using this product until repairs are made and/or factory replacement parts are installed.
- Do not use this item in a way inconsistent with the manufacturer's instructions as this could void the product warranty.
- This product is intended for residential use only.

TOOLS REQUIRED



200 LBS
TABLE
CAPACITY



250 LBS
CHAIR
CAPACITY



HARDWARE

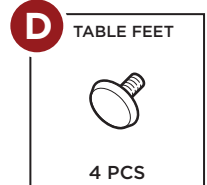
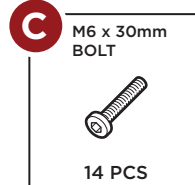
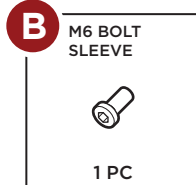
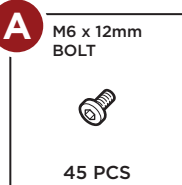

PARTS

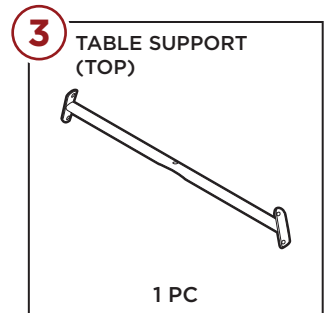
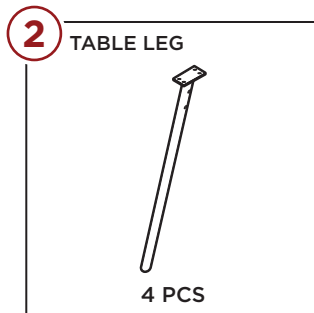
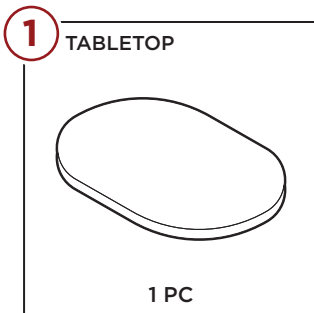

PARTS

4

TABLE SUPPORT
(BOTTOM)

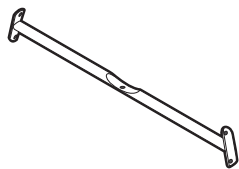

1 PC

5

BACKREST

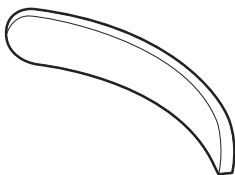

2 PCS

6

BACK SUPPORT

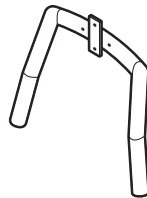

2 PCS

7

CHAIR LEGS (TOP)



2 PCS

8

CHAIR LEGS (BOTTOM)

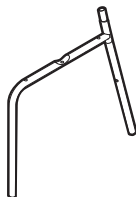

2 PCS

9

SEAT

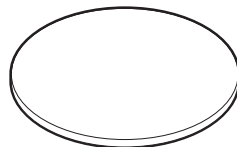

2 PCS

10

CHAIR SUPPORT BAR
(LEFT)

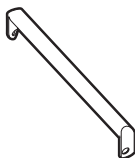

2 PCS

11

CHAIR SUPPORT BAR
(RIGHT)

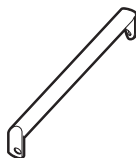

2 PCS

TABLE ASSEMBLY

1

Attach two **part 2 table legs** to the **part 3 table support (top)** with four **part A bolts**, two bolts per leg.

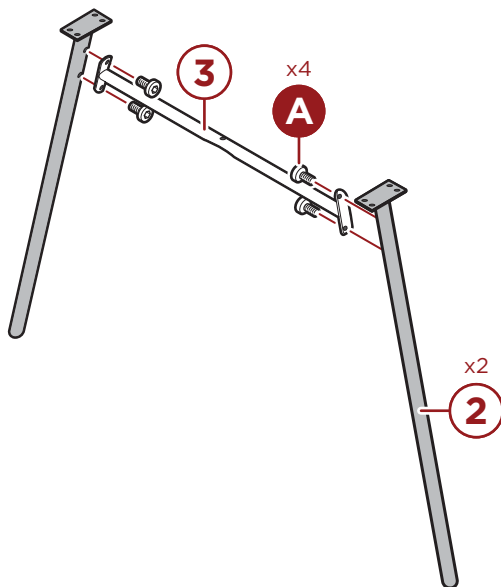

2

Attach two **part 2 table legs** to the **part 4 table support (bottom)** with four **part A bolts**, two bolts per leg.

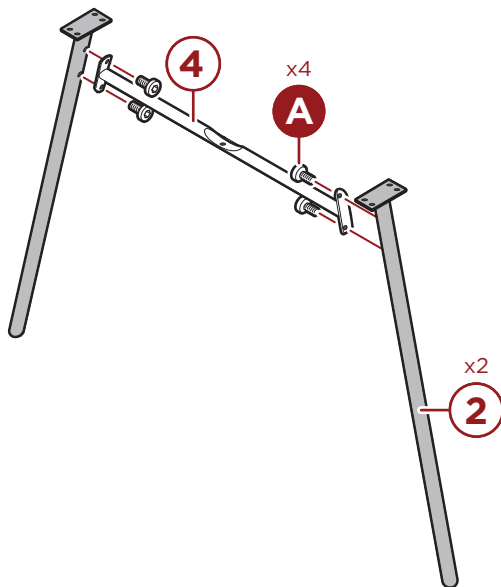
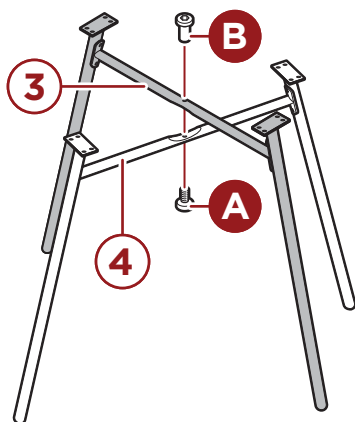

TABLE ASSEMBLY

3

Insert one **part B bolt sleeve** into the center fastener hole of the **part 3 table support (top)**.
Place the **part 4 table support (bottom)** under the **part 3 table support (top)**, then connect the two by threading one **part A bolt** into the **part B bolt sleeve**.



4

Place the **part A tabletop** top-side down on a flat, level surface, then attach the four **part 2 table legs** to the bottom of the tabletop with sixteen **part A bolts**, four bolts per leg.
Screw four **part D table feet** into the **part 2 table legs**, one foot per leg.

NOTE: Remove the protective film from the bottom of each foot before proceeding.

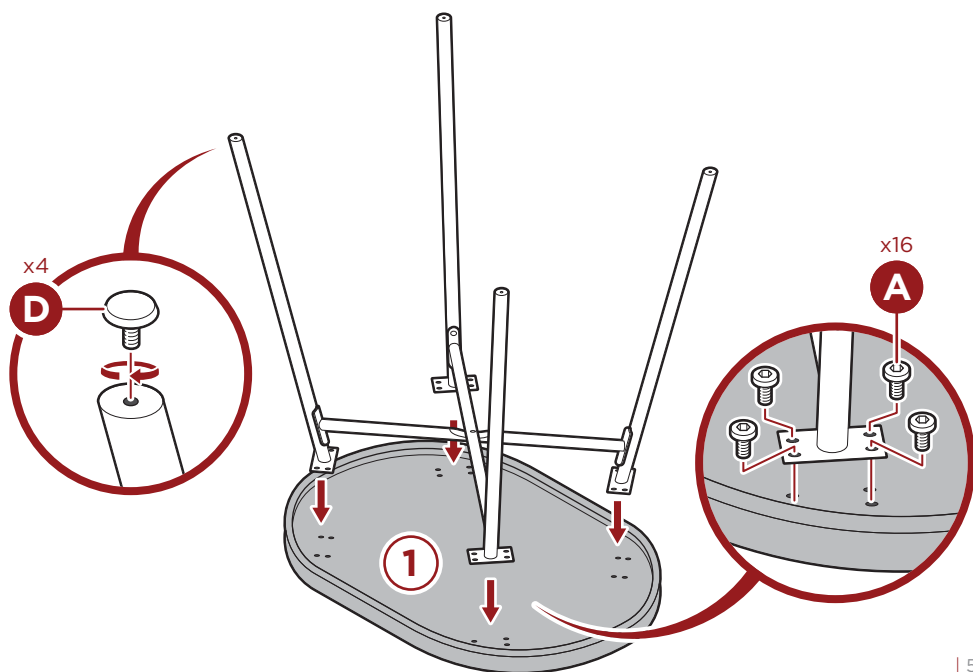

CHAIR ASSEMBLY

1

Place one set of **part 7 chair legs** on top of the **part 8 chair legs**, then interlock them by attaching one **part 10** and one **part 11 chair support bar** with four **part A bolts**, two bolts per support.

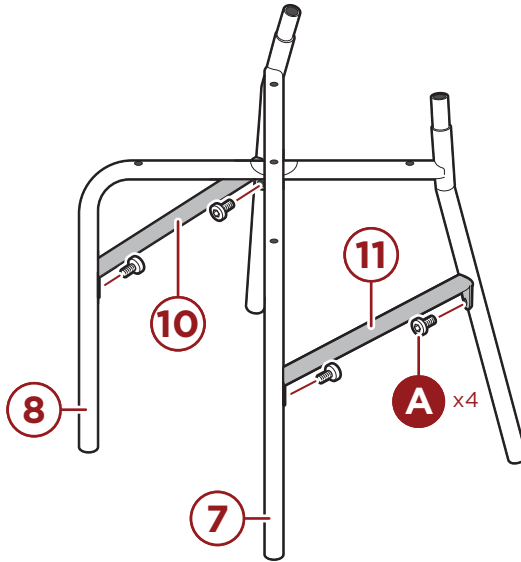

2

Place one **part 9 seat** top side down on a flat, level surface, then attach the **part 7 and 8 chair legs** to the bottom of the seat with five **part C bolts**.

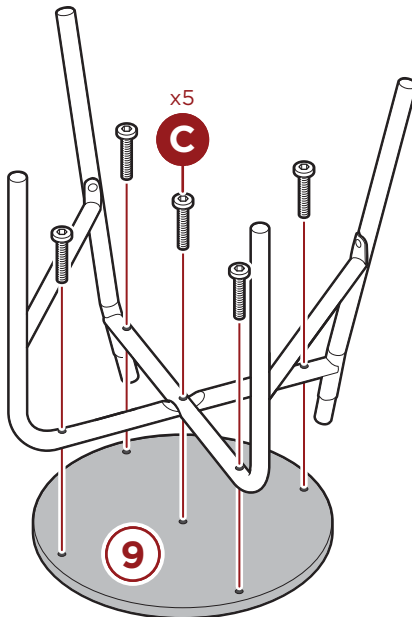

CHAIR ASSEMBLY

3

Flip the leg assembly upright, then attach one **part 6 back support** to the receivers on the **part 7 and 8 chair legs**, and secure with four **part A bolts**.

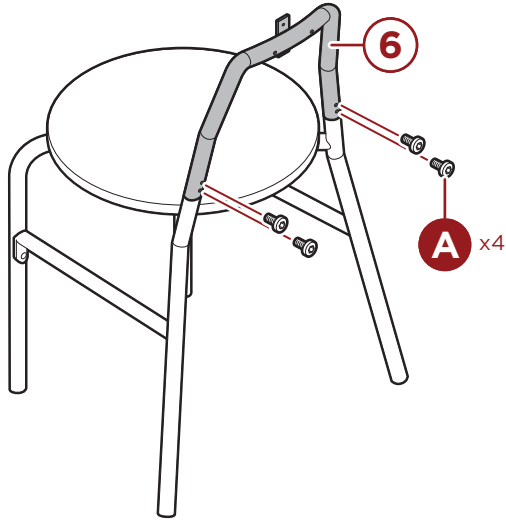

4

Attach the **part 5 backrest** to the **part 6 back support** with two **part A bolts**, and two **part C bolts**.

Repeat **steps 1-4** to assemble a second chair and enjoy.

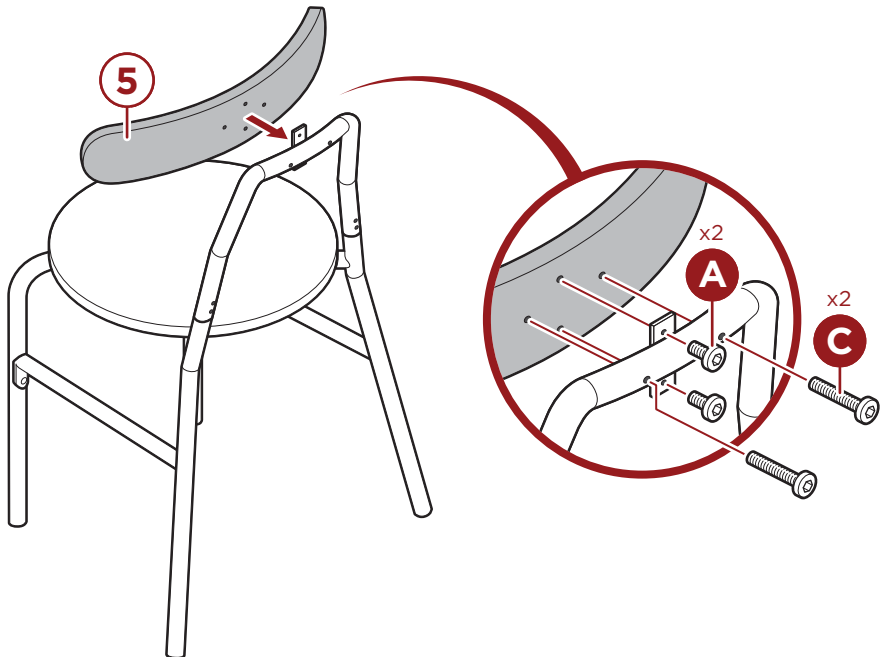



HELP CENTER



Question about your product? We're here to help. Visit us at:

help.bestchoiceproducts.com



Chat Support



Product Inquiry



Orders FAQ



Product Assembly



Returns & Refunds

PRODUCT WARRANTY INFORMATION

All items can be returned for any reason within 60 days of the receipt and will receive a full refund as long as the item is returned in its original product packaging and all accessories from its original shipment are included. All returned items will receive a full refund back to the original payment method. All returned items will not be charged a re-stocking fee.

All returned items require an RA (Return Authorization) number, which can only be provided by a Best Choice Products Customer Service Representative when the return request is submitted. Items received without an RA may not be accepted or may increase your return processing time. Once an item has been received by Best Choice Products, refunds or replacements will be processed within 5 business days.

All returns must be shipped back to the Best Choice Products Return Center at the customer's expense. If the reason for return is a result of an error by Best Choice Products then Best Choice Products will provide a pre-paid shipping label via email. Boxes for return shipping will not be provided by Best Choice Products, and is the customer's responsibility to either use the original shipping boxes or purchase new boxes.

Pictures may be required for some returns to ensure an item is not damaged prior to its return. Items returned are not considered undamaged until they are received by Best Choice Products and verified as such. All damages to items are the customer's responsibility until the item has been received by and acknowledged by Best Choice Products as undamaged.

© Best Choice Products, Inc. All rights reserved. Distributed by Best Choice Products, Inc. Tustin, CA 92780

WARNING

Manufacturer and seller expressly disclaim any and all liability for personal injury, property damage or loss, whether direct, indirect, or incidental, resulting from the incorrect attachment, improper use, inadequate maintenance, unapproved modification, or neglect of this product.