





# HEKMAN

## ASSEMBLY INSTRUCTIONS

24305-Round Coffee Table metal leg

A HOWARD MILLER COMPANY

HARDWARE LIST				
NO.	DESCRIPTION	SKETCH	DIMENSION	Q'TY
1		ALLEN KEY	5MMxL75mm	1pc
2		SPRING WASHER	Ø5/16"	12pcs
3		FLAT WASHER	Ø5/16"(19mm)	12pcs
4		BOLT	Ø5/16"x 62mm	8pcs
5		BOLT	Ø5/16"x 19mm	4pcs

**STEP 1** Lay Top Table Face down on a soft clean surface.

**STEP 2** Attach metal Legs to the top panel with Bolt #4, Lock washer #2, and Flat Washer #3, do not tighten these Bolts at this time

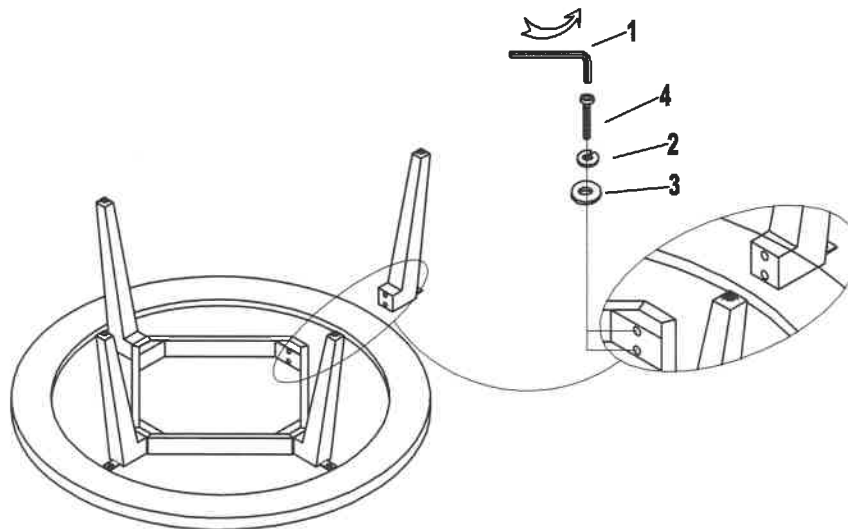

MADE IN VIETNAM

# HEKMAN

## ASSEMBLY INSTRUCTIONS

24305-Round Coffee Table metal leg

**STEP 3** Using more Bolt #5, Lock washer #2, and Flat Washer #3 to attach Legs to the Top

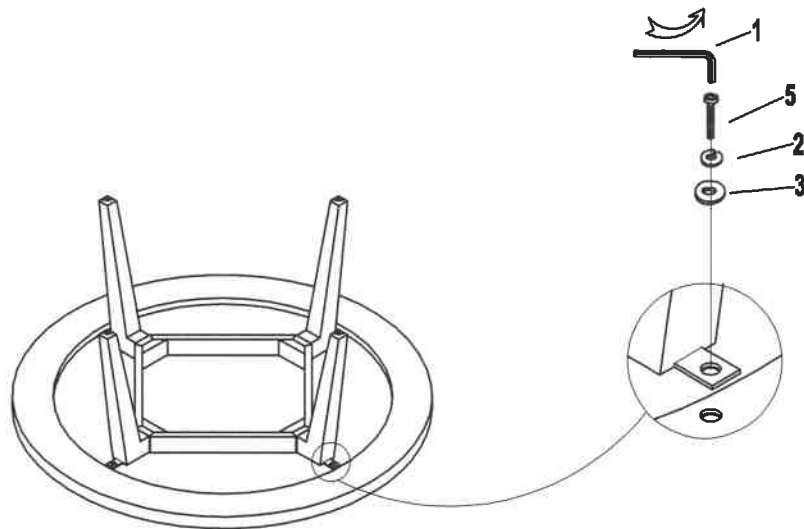

**STEP 4** Tighten all Bolts with Allen Wrench #1

**STEP 5** Turn table upright,

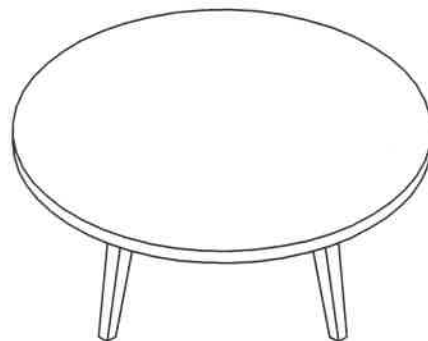

MADE IN VIETNAM