

Goalrilla

**The Toughest
Basketball System
on the Planet.**

MODEL NO.

B3222W-1

CV60

AND

B3010W-1

CV60 With STBLZR

BASKETBALL SYSTEMS

OWNER'S MANUAL

1. **Read this manual carefully before starting assembly.** Read each step completely before beginning each step.
2. **Some smaller parts may be shipped inside larger parts. Check inside all parts and cartons before assembling or ordering parts.**
3. **To make assembly of your basketball system easier, use the Hardware Identifier on page 3 and 4 to identify and sort all fasteners. Check all cartons for kits. All hardware is not located in one kit.**
4. **Do not tighten hardware until instructed to do so.** If hardware is tightened too soon, mounting holes may not align and parts may not easily fit together. Leave locknuts slightly loose until you are instructed to tighten them.
5. An electric screwdriver is helpful in assembly. However, please **set at low torque and use caution** because you could overtighten the hardware and strip the screws.
6. **Save this instruction and your proof of purchase (receipt) in the event that the manufacturer has to be contacted for replacement parts.**

Please Do Not Return This Product To The Store!

Contact Escalade® Sports customer service department at:

Phone: 1-888-USA-GOAL Toll Free !

Fax: 1-866-873-3536 Toll Free !

E-mail: basketball@escaladesports.com

Mailing Address:

Escalade Sports

PO Box 889

Evansville, IN 47706



Please Visit our Web site at: www.Goalrilla.com

ON-LINE TROUBLE SHOOTING

TECHNICAL ASSISTANCE

ON-LINE PARTS REQUESTS

FREQUENTLY ASKED QUESTIONS

ADDITIONAL ESCALADE® SPORTS PRODUCT INFORMATION

ESCALADE® SPORTS

2L-7249-04

Escalade® Sports products may be manufactured and/or licensed under the following patents.

6419596, 6179733, 5919102, 5071120, 4798381, 4424968, D326128

Additional patents may be pending. One or more of the listed patents and/or pending patents may cover specific product.

©2019 Escalade® Sports



SAFETY INSTRUCTIONS



FAILURE TO FOLLOW THESE WARNINGS MAY RESULT IN SERIOUS INJURY AND/OR PROPERTY DAMAGE.

Owner must ensure that all players know and follow these rules for safe operation of the system.



WARNING

FAILURE TO FOLLOW THESE WARNINGS MAY RESULT IN SERIOUS INJURY AND/OR PROPERTY DAMAGE.

Owner must ensure that all players know and follow these rules for safe operation of the system.

- Only hang from the rim briefly to regain balance or avoid injuring others. Release the rim as soon as safely possible.
- During play, especially when performing dunk type activities, keep player's face away from the backboard, rim, and net. Serious injury could occur if teeth/face come in contact with backboard, rim, or net.
- Do not slide, climb, or play on pole.
- When adjusting height, keep hands and fingers away from moving parts.
- Do not allow children to adjust system.
- During play, do not wear jewelry (rings, watches, necklaces, etc.) Objects may entangle in net.
- Keep water and organic material away from pole. Pole can rust and fail.
- Once a month check pole and all metal parts for rust. Completely remove rust and repaint with exterior enamel. If rust has penetrated any steel part, replace that part immediately.
- Check system before each use for loose hardware, signs of rust and instability. Repair before each use. Never play on damaged equipment.
- Wear a mouthguard when playing to avoid dental injuries.



SAFETY INSTRUCTIONS



FAILURE TO FOLLOW THESE SAFETY INSTRUCTIONS MAY RESULT IN SERIOUS INJURY, PROPERTY DAMAGE AND WILL VOID WARRANTY.

Owner must ensure that all players know and follow these rules for safe operation of the system.

To ensure safety, do not attempt to assemble this system without following the instructions carefully. Proper and complete assembly, use and supervision is essential for proper operation and to reduce the risk of accident or injury. A high probability of serious injury exists if this system is not installed, maintained, and operated properly.

- If using a ladder during assembly, use extreme caution.
- 4 people are recommended for this operation.
- Seat the pole sections properly (if applicable). Failure to do so could allow the pole sections to separate during play.
- Before digging contact utility company to locate underground power cables, gas and water lines. Ensure there are no overhead power lines within 20 ft. (7m) radius of pole location.
- Climate, corrosion or misuse could result in system failure.
- If technical assistance is required, contact the manufacturer.
- Minimum operational height is 6'6" (1.98m) to the bottom of backboard.

*Most injuries are caused by misuse and/or not following instructions.
Use caution when using this system.*

WARNING!

Failure to observe this warning may cause property damage and/or serious injury.

(Affixed to backboard)

Only hang from the rim briefly to regain balance or avoid injuring others. Release the rim as soon as safely possible. Rim height adjustments should be made under parental supervision. Wear a mouth guard when playing to avoid dental injuries. During play, do not wear jewelry (rings, watches, necklaces, etc). Objects may entangle in net.

HARDWARE IDENTIFIER

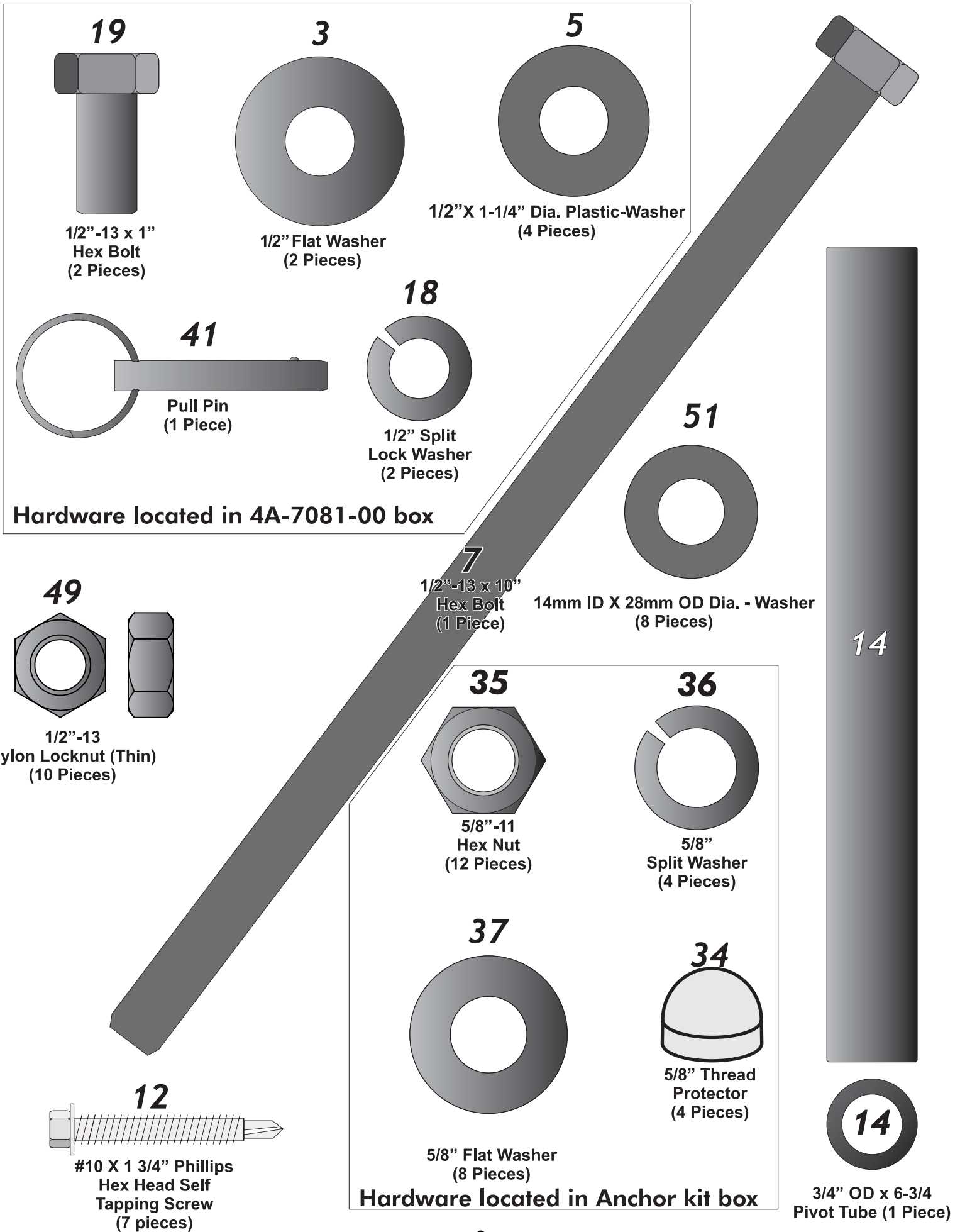

HARDWARE IDENTIFIER

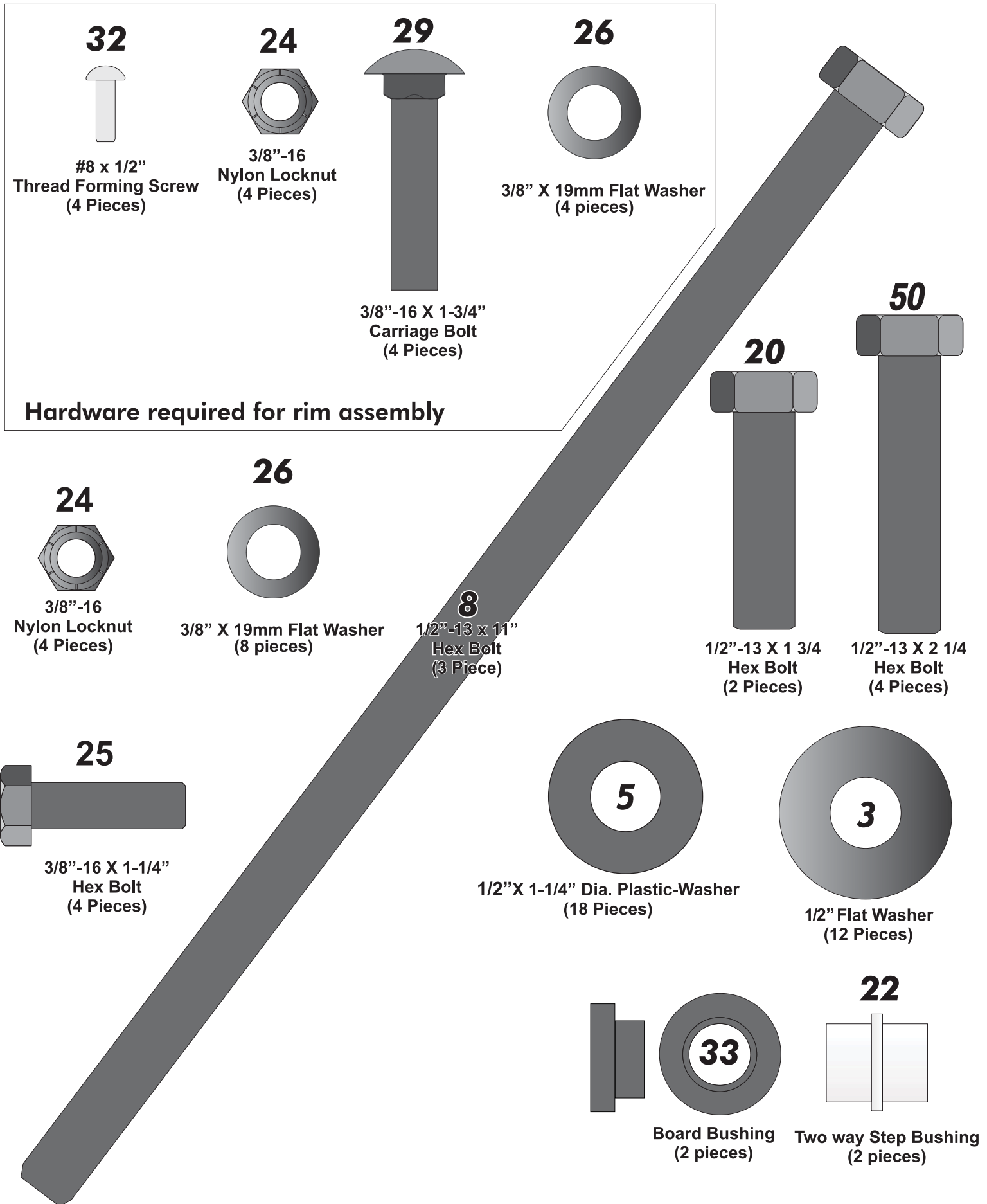

INSTALLATION TIMELINE

1. Prior to anchor system and goal assembly, call utility services for location of underground utility lines before you dig.
2. Vertical main post assembly is a two part process.

PART 1

Day 1. Complete Anchor System Installation Instructions. (Below)

Day 2-4. Allow concrete to cure.

PART 2

Day 5. Complete Goalrilla™ assembly instructions. (Requires four adults)

ANCHOR SYSTEM INSTALLATION INSTRUCTIONS (Day 1)

WARNING

Before digging hole for anchor system, check for buried power, gas, water, and telecommunication lines! Failure to do so could result in serious or fatal injury! Contact your local utility company if unsure.

Items needed for Anchor Installation (not included)

- | | |
|--|------------------|
| 11 - 80 lb. bags of concrete (2-3 extra recommended) | 1 - wheel barrow |
| 1 - post hole digger (optional) | 1 - garden hose |
| 1 - 15/16" open end wrench | 1 - level |
| 1 - 15/16" socket and ratchet (optional) | 1 - tape measure |
| 1 - concrete form (see note after step 2) | |

Note: For best results with less vibration, anchor system should be independent of court. If pouring concrete for both at same time, add an expansion joint in between.

Note: When digging hole, if you hit rock and cannot dig through contact a contractor.

1. Determine the location of the anchor system. The proper location is as **close to the court without making contact**, as shown in Figure 1. This, however, is a general rule. If you need to locate the anchor system in a location other than this, use the following dimensions as a guide.

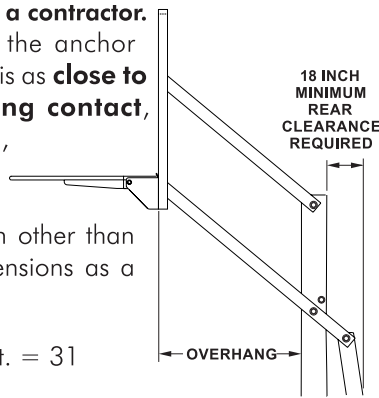

Overhang when adjusted to 10 ft. = 31

2. Assemble anchor system as follows: Thread nut (#35) to bottom of threads on anchor bolt (#39) insert threads of anchor bolt (#39) through hole on anchor plate (#38) and secure with nut (#35). Repeat this step for the remaining anchor bolts. See Figure 2. Note: Each leg of anchor bolts should face the anchor bolt to the right. See Detail A.

Detail A
Bottom View

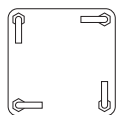

Figure 2

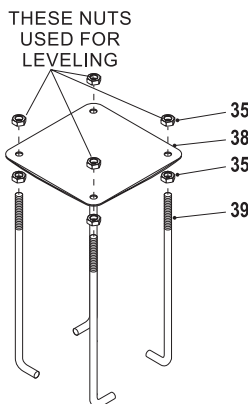
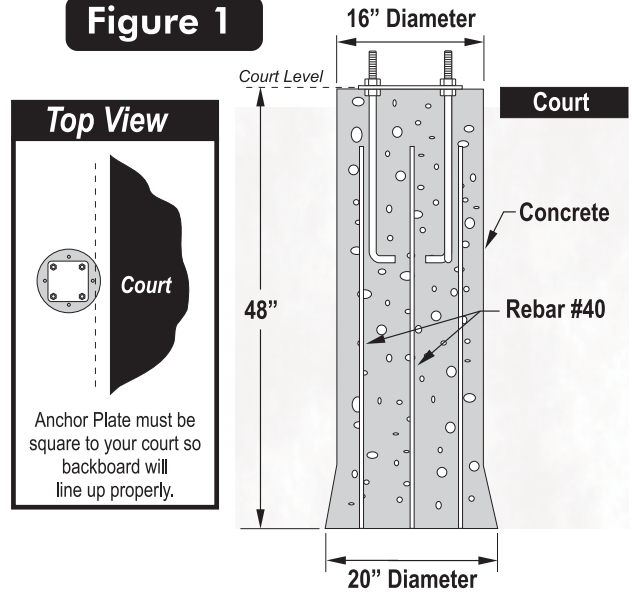

Figure 1



Note: Using a concrete form for the top 4" of the concrete is recommended. Cardboard forms can be purchased at some hardware and home stores or a wooden form can be constructed out of 2 x 4's.

Note: Failure to dig and fill hole as instructed will result in increased system vibration.

***Tip: It is always a good idea to purchase one or two extra bags of concrete, just in case you need them. If extra bags are not used you can return them to the store.**

3. Mix and pour concrete into hole. Follow instructions on concrete bag. Stop about 18" below court level.
4. Insert four reinforcement bars (#40) into concrete 8" apart creating a square in center on hole.
5. Place form in desired location and finish pouring concrete up to court level.
6. Push anchor system into concrete and agitate to work out voids in concrete. Immediately use a level to level and square anchor plate to playing surface. Clean off any concrete that may be on exposed threads.

Note: The bottom four nuts will be forever embedded in concrete. The top four nuts remain on bolts and are used for leveling. (See Step 11 on page 10)

Let concrete stand for a MINIMUM of 72 hours.

GOALRILLA™ ASSEMBLY INSTRUCTIONS (Day 5)

TOOLS REQUIRED FOR THE FOLLOWING STEPS

1 - 15/16" open end wrench	1 - 1/2" Socket
1 - 15/16" socket and ratchet (optional)	1 - Level
1 - 9/16" Deep Well Socket & Ratchet	1 - Tape Measure
1 - 3/4" Socket & Ratchet	1 - Rubber Mallet
1 - 3/4" Open end Wrench	1 - Set of Padded Saw Horses
1 - Cordless Drill & 9/64" Drill Bit	1 - Ladder
1 - 5/16" Hex Nut Socket Driver (Used for screws #12 & #60)	1 - Pair of Safety Glasses
	1 - Phillips Screwdriver

1. Attach Post Brackets (#48) to outside of brackets on back of Post Assembly (#2). Secure with two Hex Head Bolts (#25), four Flat Head Washers (#26) and two Locknuts (#24) in **each Bracket** (#48). See Figure 3.
2. If not already pre-assembled, slide Plastic Actuator Sleeve (#15) over Steel Actuator (#16) and place Actuator Cap (#13) on top. **Align holes in all 3 parts** and slide Pivot Tube (#14) through holes in Actuator Cap (#13) Plastic Actuator Sleeve (#15) and Steel Actuator (#16) until equal amounts stick out through both sides of actuator. See **Figure 4**.

NOTE: It may be necessary to use a rubber mallet to tap in Pivot Tube.

NOTE: It is important for the installer to understand the necessity of the Plastic washers (#5) provided. These washers adequately space painted parts at all pivot points. Neglecting the use of these washers will result in rusted parts.

3. Lay Pole (#2) on its side on two padded saw horses. Attach Actuator (#16) to Pole (#2) using one bolt (#19), split lockwasher (#18), washer (#3) and two plastic washers (#5) to thread into each side of Actuator. See Figure 4. Tighten bolts tight.

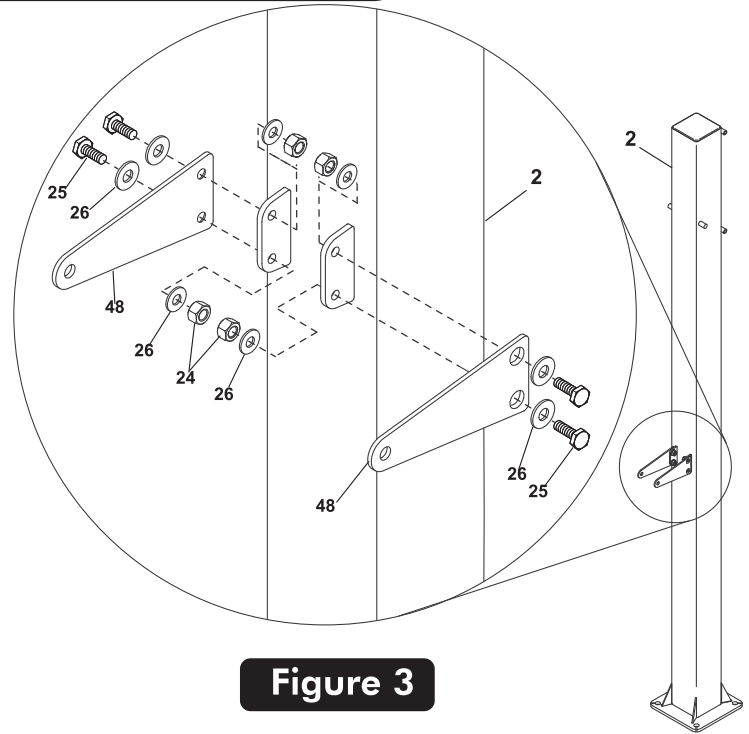

Figure 3

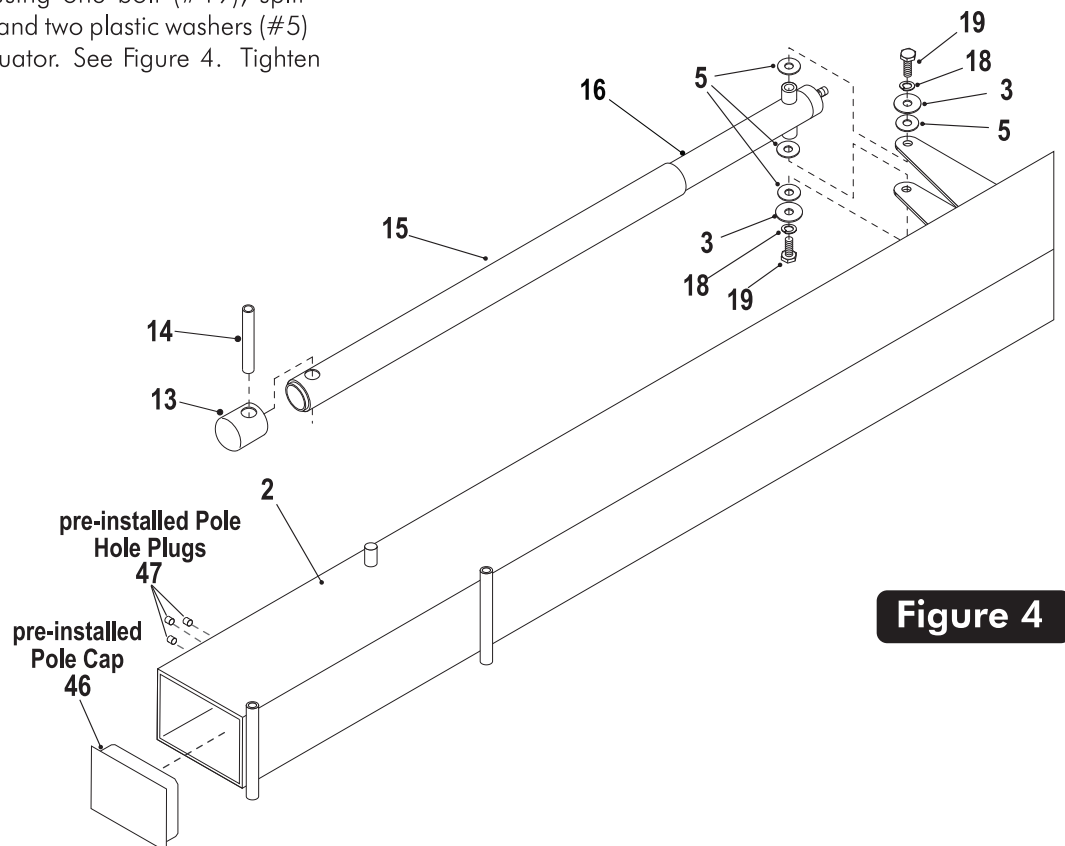

Figure 4

NOTE: It is important for the installer to understand the necessity of the Plastic washers (#5) provided. These washers adequately space painted parts at all pivot points. Neglecting the use of these washers will result in rusted parts.

NOTE: All board arms are made of rectangular tubing. Tightening hardware too tight may damage tubing and make adjustment of system difficult.

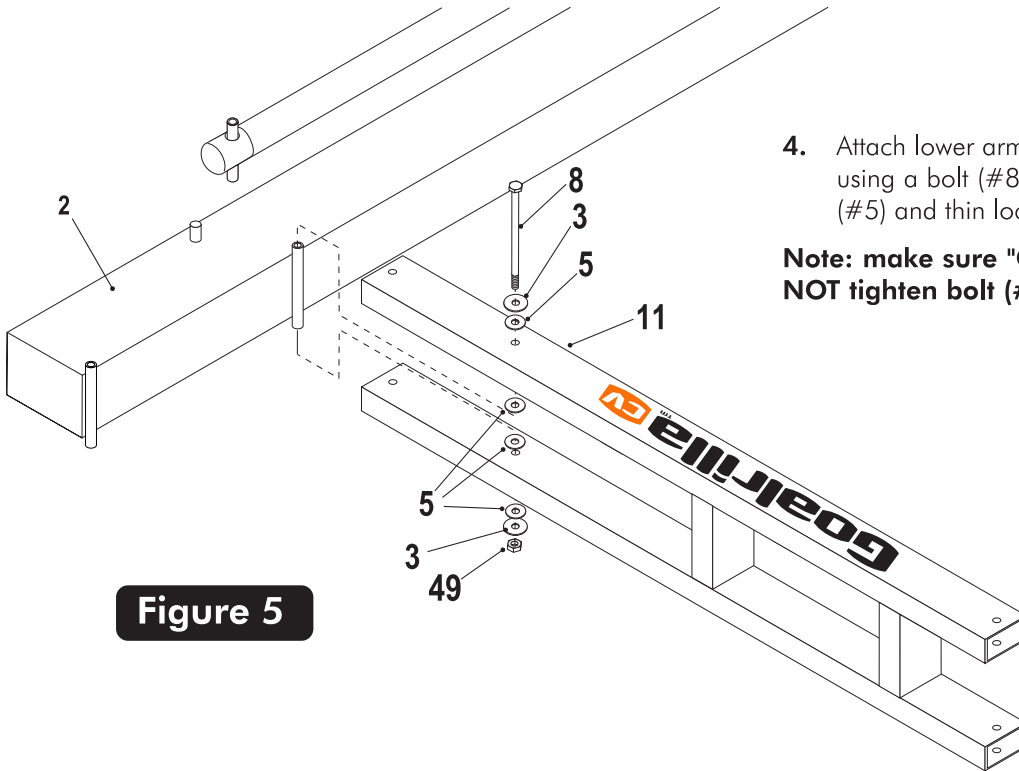

Figure 5

- Attach lower arm (#11) to Pole (#2), as shown in Figure 5, using a bolt (#8), two flatwashers (#3), four plastic washers (#5) and thin locknut (#49).

Note: make sure "Goalrilla" lettering is right side up. Do NOT tighten bolt (#8) at this time.

- Secure Actuator (#16) to Lower Arm (#11) using one bolt (#8), two flatwashers (#3), four plastic washers (#5) and one thin locknut (#49). See Figure 6. Tighten both bolts (#8) snug but, do not over tighten. Board Arms must pivot freely.

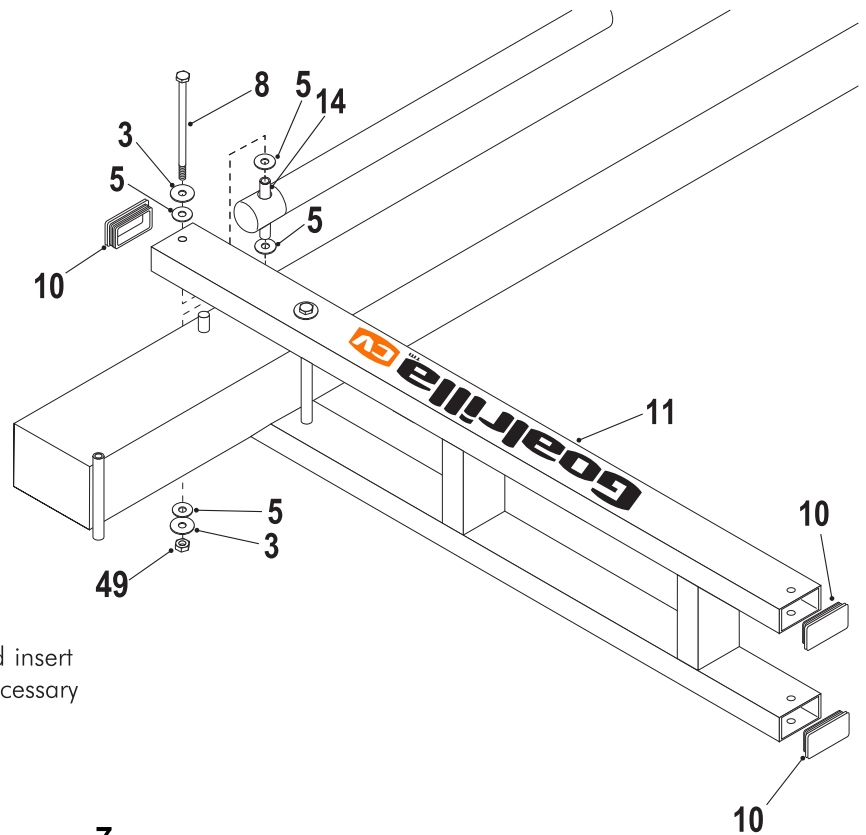

Figure 6

- If the four Tube Plugs (#10) are not already installed insert them into open ends of Lower Arm (#11). It may be necessary to use a rubber mallet to tap plug in.

7. Attach Upper Arms (#6L & 6R) to pole (#2), as shown in Figure 7. Using a bolt (#7), two flatwashers (#3), four plastic washers (#5) and hex nut (#49).

Note: Tighten bolts snug but, do not over tighten. Board Arms must pivot freely.

8. If the two Tube Plugs (#9) are not already installed insert them into open ends of Upper Arms (#6L and 6R). It may be necessary to use a rubber mallet to tap plug in.

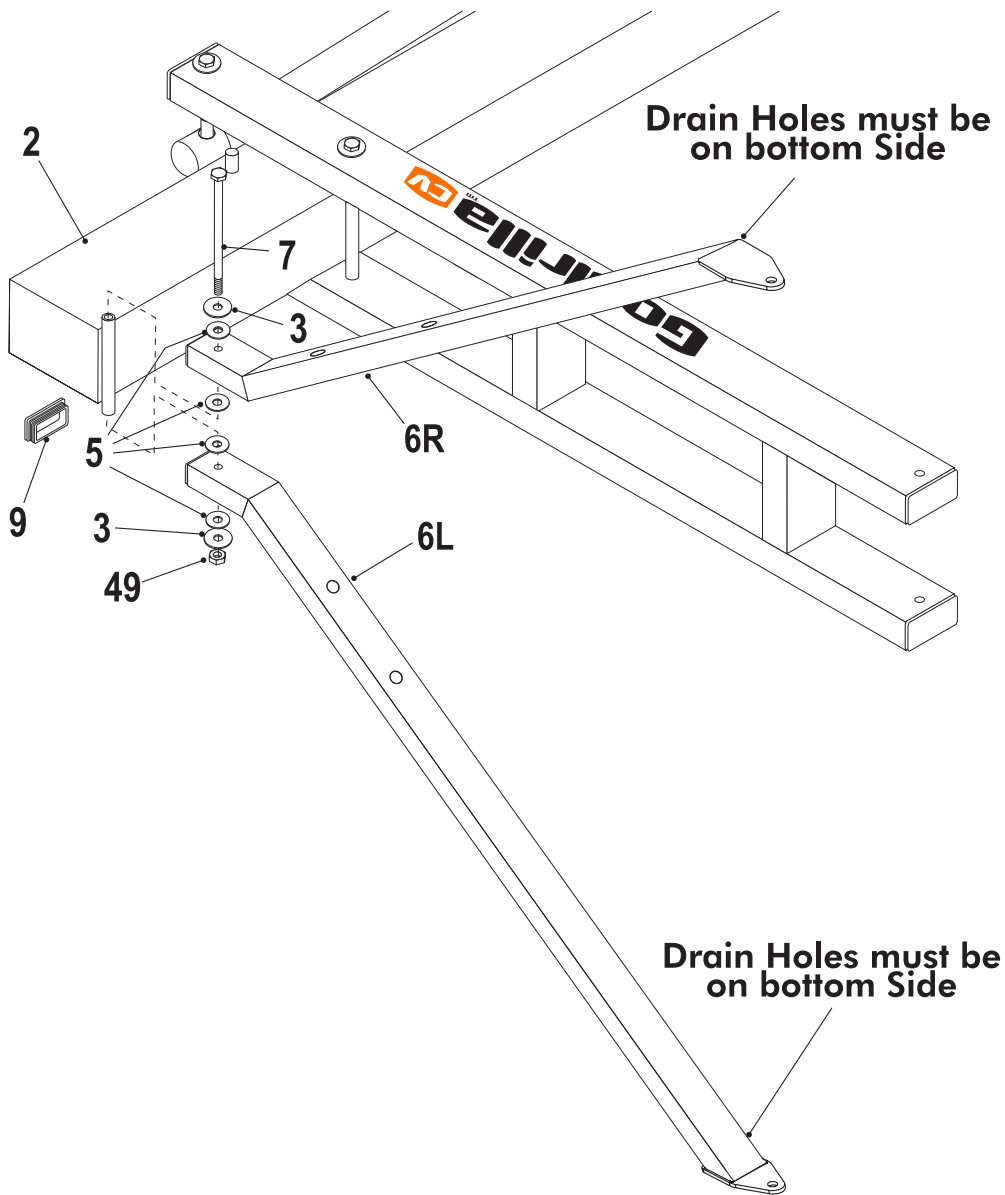

Figure 7



NOTICE

IF YOU ARE ASSEMBLING MODEL **B3010W-1 CV60 WITH STBLZR** PROCEED WITH INSTALLATION OF STBLZR UNIT PER INSTRUCTIONS INCLUDED IN **B3012W CV60 STBLZR KIT**. FOR **B3222W-1** UNIT WITHOUT STBLZR CONTINUE TO NEXT PAGE.

9. Locate hardware needed to mount pole to anchor bolts. You will need, eight flat washers (#37), four lock washers (#36), four hex nuts (#35) and four thread protectors (#34).

NOTE: Do not remove the nuts #35 you installed in step 2 (pg. 5).



10. Put a flat washer (#37) on each anchor bolt. Lift post onto anchor system and secure with one flatwasher (#37), one lock washer (#36) and one hex nut (#35) for each anchor bolt. Tighten Fasteners finger tight, leave loose enough to level pole. Place a level on pole and adjust bottom nuts #35 until pole is level (left to right and front to back).

Tighten top four hex nuts #35 tight. See **Figure 8**.

11. Push on Thread Protector Cap (#34) until it is securely in place. Cap may be tight, push hard but **DO NOT** hit with a hammer! See **Figure 8** and **Detail A**.

Let concrete cure for a **MINIMUM** of **72** hours.

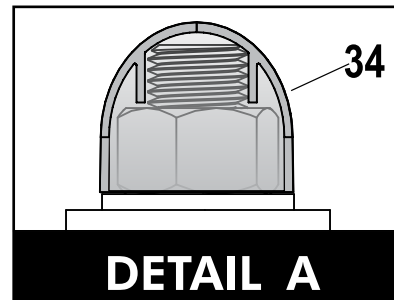
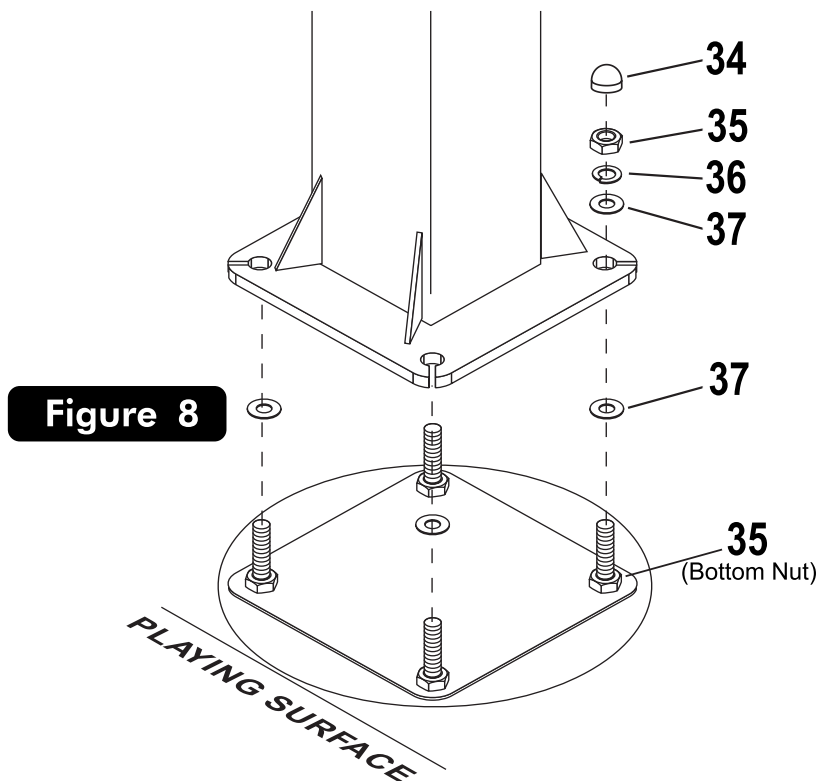

NOTE:

If basketball system needs to be moved, **do not** try to salvage caps. Caps (#34) will be tight, please remove with pliers and discard. New caps will come in new anchor system.

NOTE:

If (#34) caps are missing for any reason please call customer service.

NOTE:

Bottom nuts #35 can be used for leveling system. See **Step 10**.

12. Slide Actuator Handle (#42) onto shaft on the back of Actuator (#16). Line up hole in shaft with hole in Actuator Handle and insert Pull Pin (#41) to secure.
13. To aid in the assembly of the backboard lower the lower board arm (#11), by turning the Actuator Crank, until the lower arm makes contact with the Safety Stop.

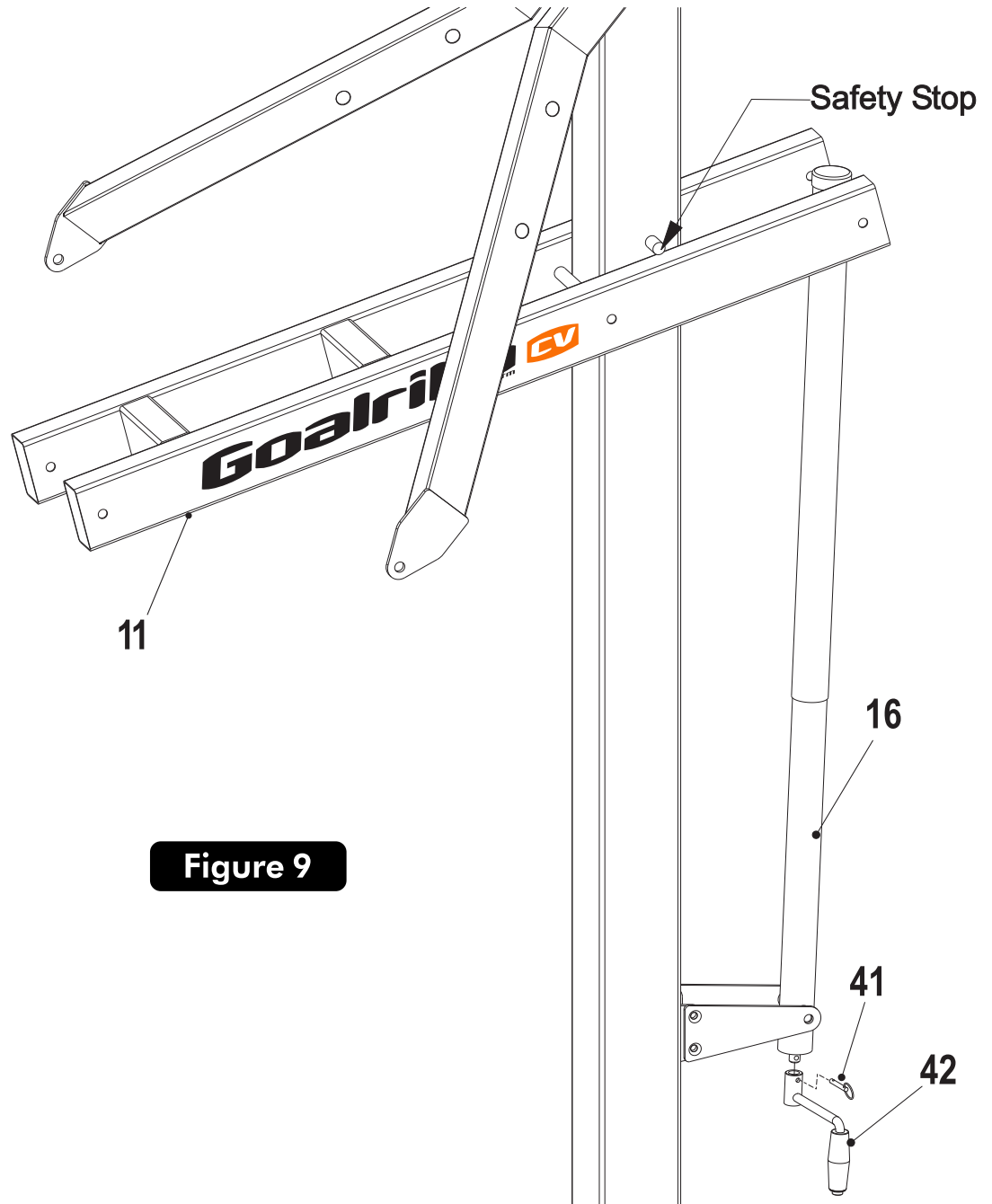
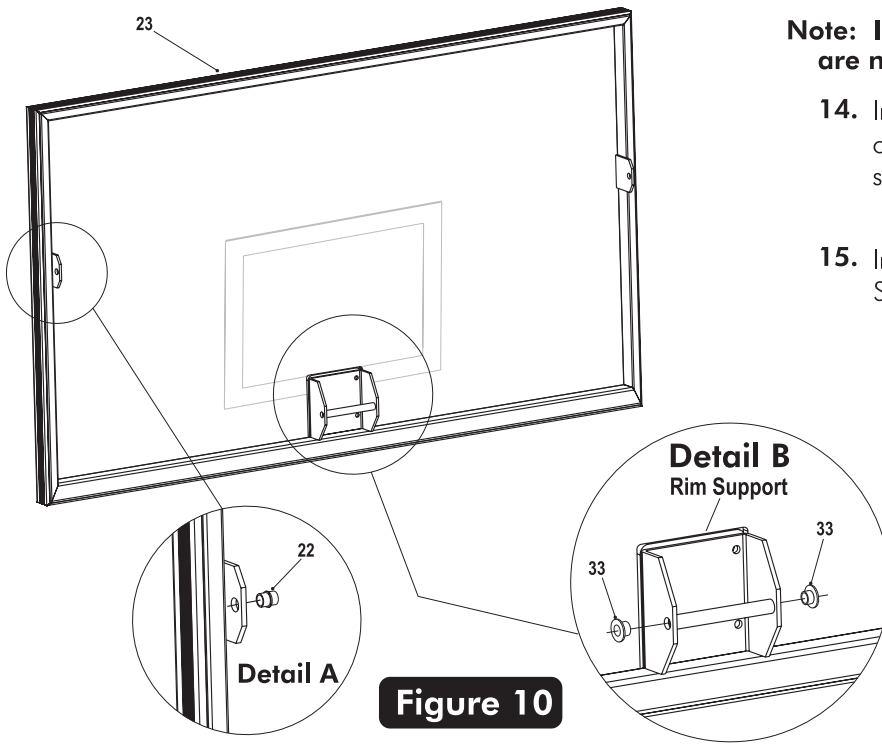

Figure 9



Note: If the Step Bushing (#22) and Board Bushing (#33) are not already pre-installed follow steps 14 and 15.

14. Insert a Two Way Step Bushing (#22) in to the inside of bracket on each side of the Backboard (#23) as shown in Detail A.

15. Insert two Board Bushings (#33) in to the rim support. See Detail B.

Figure 10

CAUTION

ATTACHING BACKBOARD TO BOARD ARMS REQUIRES AT LEAST FIVE CAPABLE ADULTS.

CAUTION

HANDLE BACKBOARD WITH CARE, IT IS A GLASS PRODUCT ALWAYS WEAR SAFETY GLASSES AND GLOVES WHEN HANDLING GLASS.

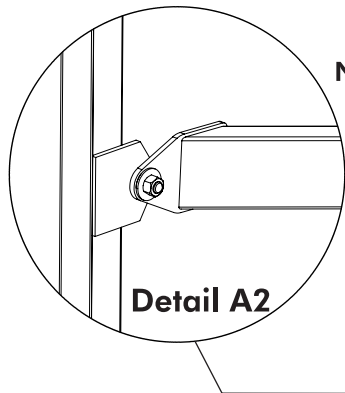

Note: Be sure to install upper board arms to the **INSIDE** of backboard mounting brackets.

16. With at least **four** capable people, raise the backboard assembly up and have the fifth person attach Lower Board Arms to the Rim Support on backboard using one bolt (#8), two washers (#3), two Plastic washers (#5) and one thin locknut (#49). See **Figure 11**.

Note: DO NOT over tighten these bolts. This is a pivot point. Snug is tight enough.

17. Attach Upper Board Arms to the **inside** of upper mounting brackets on the backboard using two bolts (#20), four Washers (#3), four Plastic Washers (#5) and two Locknuts (#49). See **Figure 11 & Detail A2**. **Tighten fasteners but leave loose enough attach Upper Arm Cross Brace on the next step.**

Note: DO NOT over tighten these bolts. This is a pivot point. Snug is tight enough.

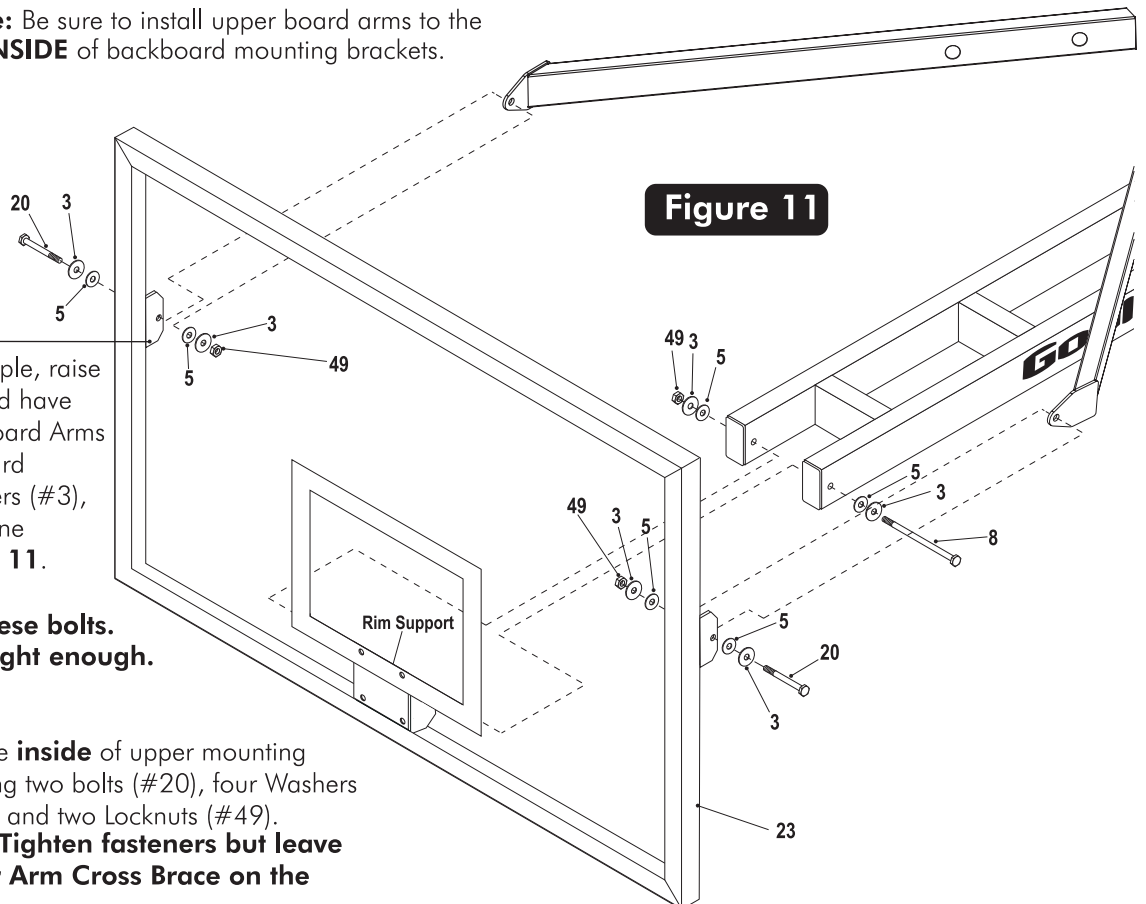
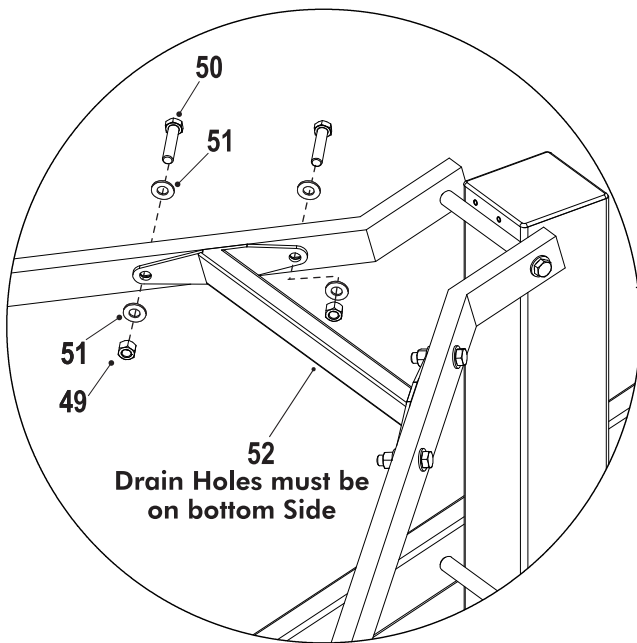

Figure 11



52
Drain Holes must be
on bottom Side

***Backboard not
shown for clarity.**

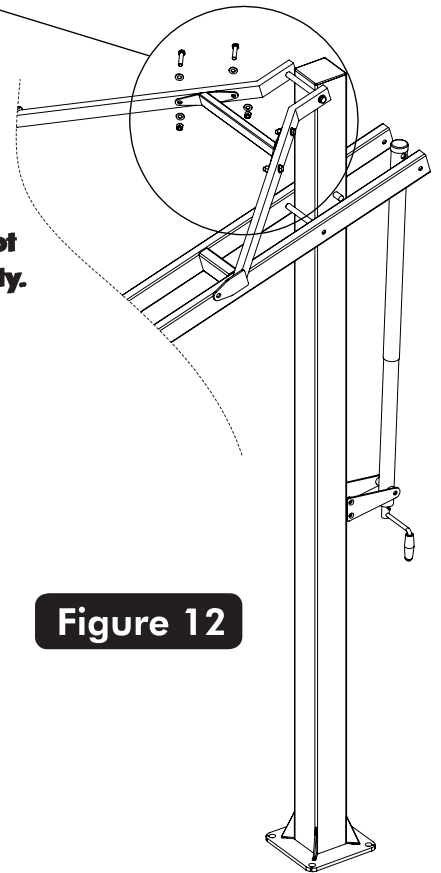

Figure 12

18. With the help of another adult attach the Cross brace (#52) with four Bolts (#50), eight Washers (#51) and four Nuts (#49) as shown in Figure 12 and Detail C.

Make sure that drain holes are on the bottom side of the Cross Brace.

19. Tighten all hardware at this time including hardware that was attached in **step 17**.

Note: DO NOT over tighten these bolts. Snug is tight enough.

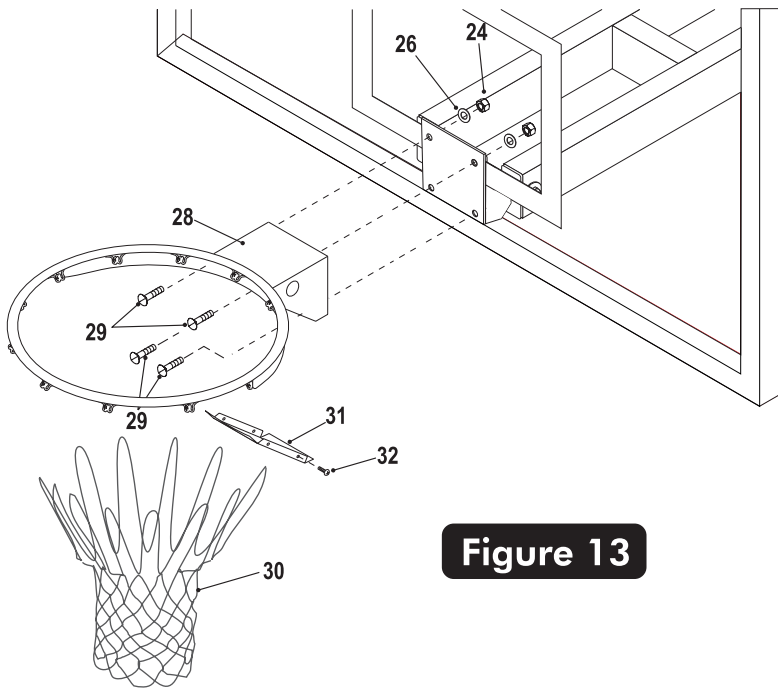

Figure 13

! CAUTION !
INSTALL RIM EXACTLY AS SHOWN. FAILURE TO DO SO COULD DAMAGE GLASS.

20. Mount Goal Assembly (#28) to Backboard as shown in Figure 13, using four bolts (#29), four washers (#26) and four nuts (#24). Tighten Fasteners but leave loose enough to level rim.

21. Place a level across rim assembly and adjust rim until it is level. Finish tightening the four nuts.

! CAUTION !
NEVER USE RIM WITH COVERPLATE REMOVED!

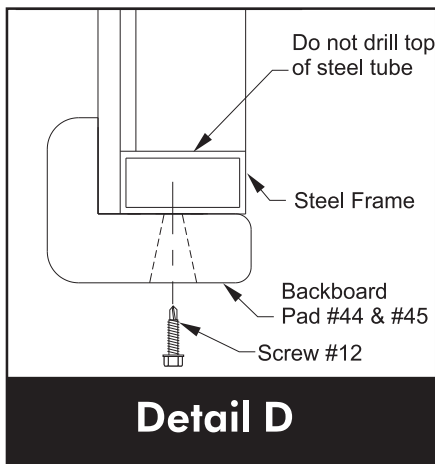

Detail D

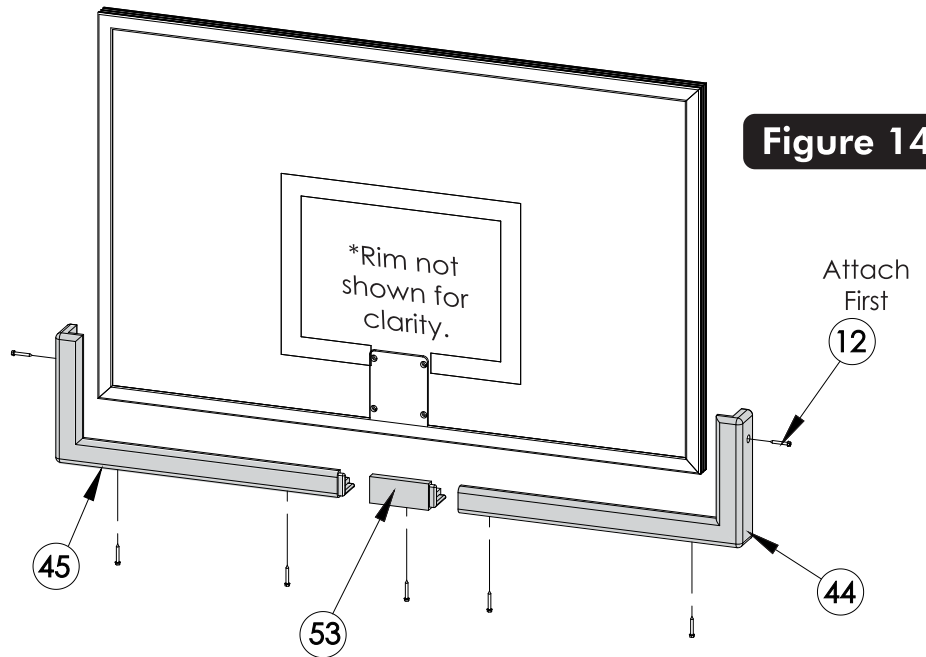

Figure 14

22. Use the Backboard Pads as a Template and mark the hole locations on the backboard frame.

Note: Safety glasses required for Step 23.

23. Drill 9/64 pilot holes through aluminum trim and into Steel backboard frame as shown in **Detail D**. **DO NOT** drill through both sides of tube.

Note: Cordless drill recommended for screw installation. Do not over tighten screws causing Screws to strip.

Note: To install screws, it will be easier if you use a cordless drill with 5/16" socket driver (instead of Phillips head.)

24. Secure Backboard pads using screws provided (#12). Start with the Right Board Pad (#44) secure it by screwing the top (#12) screw all the way in. Next Insert the other two (#12) screws to the pre-drilled holes enough to hold pad but **do not** tighten all the way.

25. Slide Middle Pad (#53) into the (#44) pad and insert screw (#12) to the pre-drilled holes to hold pad in place. **Do not** tighten all the way.

26. Attach Left Board Pad (#45) and secure it by screwing the top (#12) screw all the way in. Next Insert the other two (#12) screws to the pre-drilled holes to hold pad but **do not** tighten all the way. Slide pads together and tighten all screws at this time.

NOTE:

Two adults are recommended for this step, one to level and one to adjust the bottom #35 nuts.

27. If further leveling is required loosen top #35 nuts but do not loosen past the top of #39 "J" Bolt. **DO NOT REMOVE NUTS #35.** Place a level on pole and adjust bottom nuts #35 with a 15/16" open end wrench until pole is level. Tighten top #35 hex nuts. See **Detail E**.

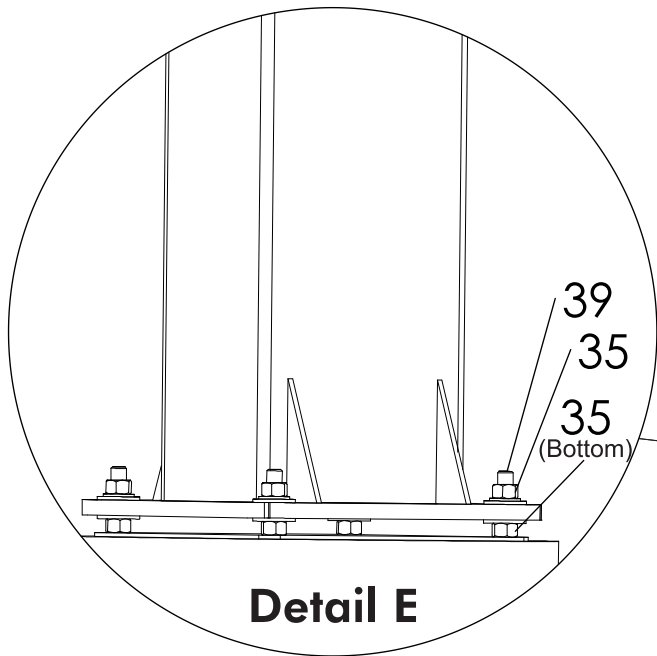

Detail E

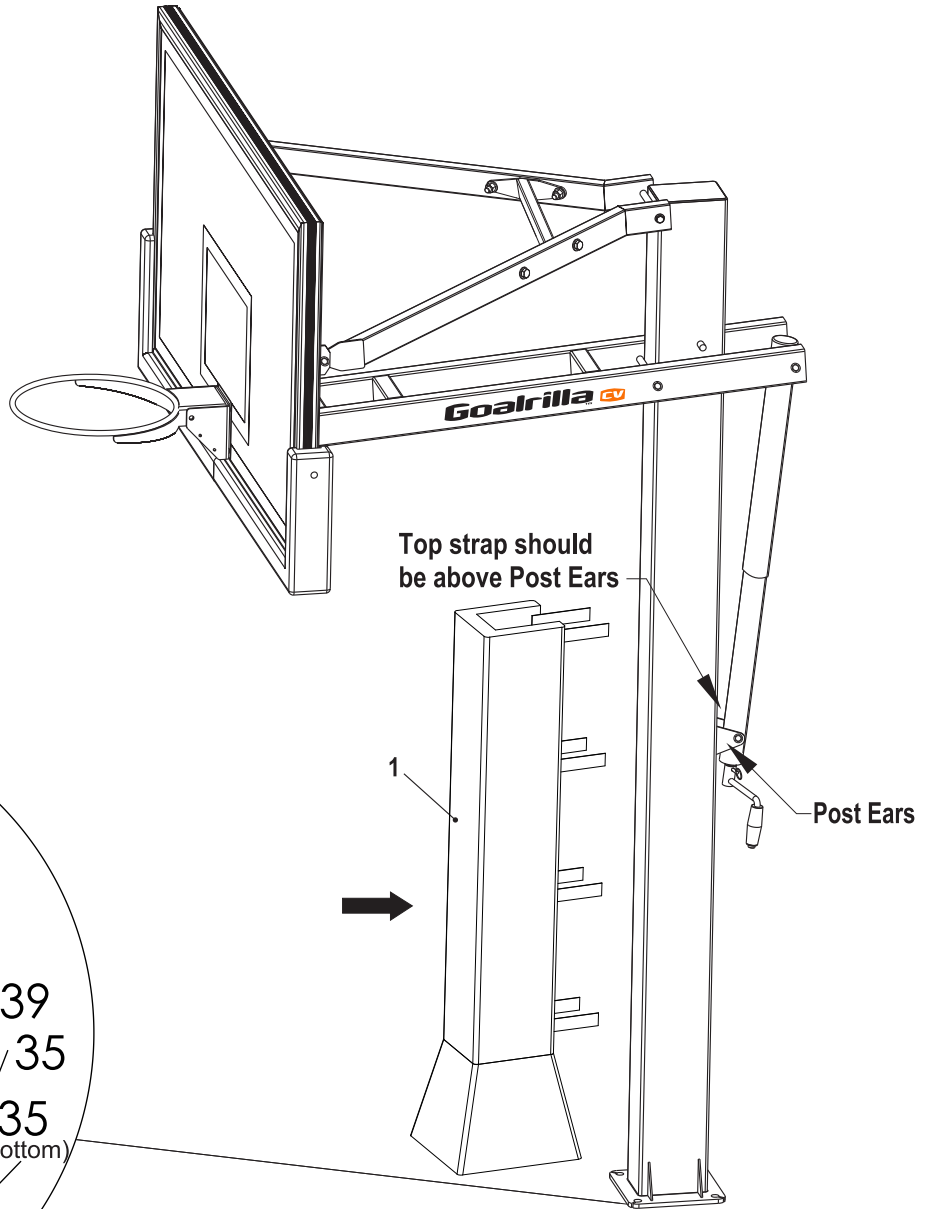

Figure 15

28. Secure Post Pad (#1) to front of pole by wrapping straps around the back pole and sticking to velcro on opposite side of Pad. Top Post Pad straps should be above Post Ears. See **Figure 15**.

29. Raise Backboard to 10 FT. regulation playing height. Measure from top of rim straight down to the playing surface.

30. Using tape - mark the **side** of the steel actuator (#16) just under the plastic actuator sleeve (#15) at this 10 ft rim height. See **Figure 16**.

31. Lower backboard all the way down. Do not force actuator once backboard is in it's lowest position. See **Figure 17**.

32. **Do not** remove adhesive backing from height decal (#17) yet. Carefully place height decal on backside of steel actuator (#16) and line up the 10 ft mark on the tape with the 10 ft mark on the height decal. Decal should fit correctly onto the backside of the steel actuator. (If not , simply trim to fit the top of the actuator decal).

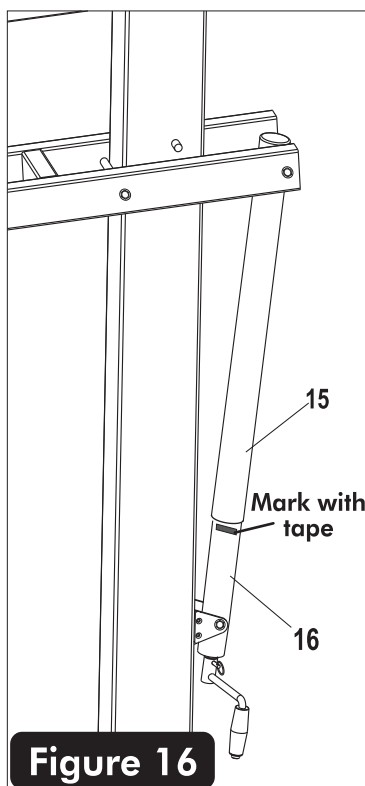

Figure 16

Set at 10 feet

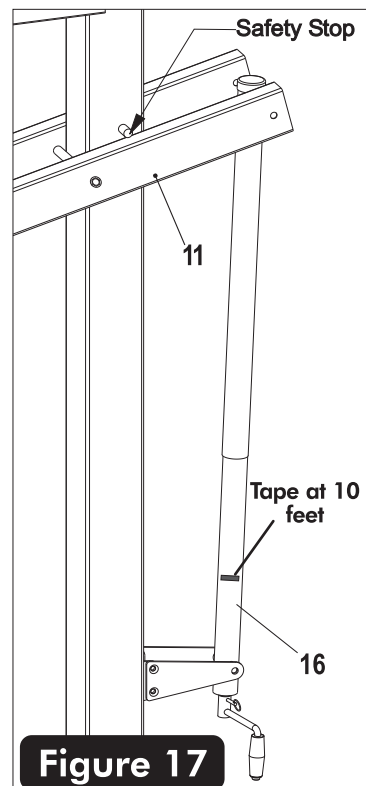

Figure 17

Lowered all the way down

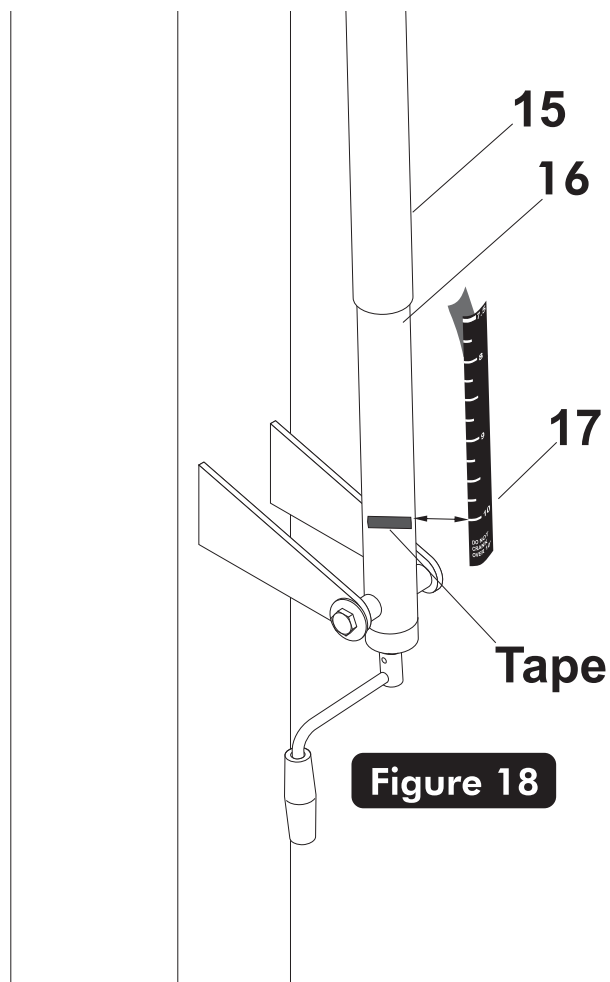

Figure 18

33. Remove the adhesive backing from the Height Decal (#17). Next, carefully align and stick decal to backside of steel actuator (#16) starting at the **10 ft mark first**. Be sure to keep the height decal straight and rub out all air bubbles. See **Figure 18**.

CARE AND MAINTENANCE

BACKBOARD CARE AND MAINTENANCE

Items needed to clean backboard:

- 100% cotton soft cloth, (only)
- Glass cleaner

Clean backboard using only a **100% Cotton** soft cloth and glass cleaner. Clean glass as you would clean household windows. Strong cleansers will damage backboard and void warranty.

RIM

Only hang from the rim briefly to regain balance or avoid injuring others. Release the rim as soon as safely possible. Rims are not warranted for any defects other than workmanship. Torn back plates, damaged springs, bent rings, damaged eye bolts, and torn or distorted rim supports result from hanging on the rim and are not warranted.

The goal should not be cranked over 10'. Adjustments of the goal should be done under adult supervision.

When attempting slam dunk activity you should always wear a mouth guard to avoid dental injury.

MAINTENANCE

To ensure ease of operation, lubricate all pivot points at least every 6 months or as needed with a good lubricant such as WD-40.

RUST

Inspect your pole periodically, if rust should appear, remove loose paint, sand lightly, primer and paint with exterior flat matte finish enamel paint.

LIMITED LIFETIME WARRANTY

This consumer warranty extends to the original consumer purchase of any Escalade® Sports Product (hereinafter referred to as the "Product").

WARRANTY COVERAGE: Escalade® Sports warrants to the original Consumer Purchaser that any Product of its manufacture is free from defects in material and workmanship. THIS WARRANTY IS VOID IF THE PRODUCT HAS BEEN DAMAGED BY ACCIDENT, UNREASONABLE USE, NEGLIGENCE, IMPROPER SERVICE, FAILURE TO FOLLOW INSTRUCTIONS PROVIDED WITH THE PRODUCT OR OTHER CAUSES NOT ARISING OUT OF DEFECTS IN MATERIAL OR WORKMANSHIP.

Subject to proper installation and normal Residential use, Escalade® Sports warrants, subject to the limitations below, to the original retail purchaser all structural components of the Goalrilla™ System to be free of defects in material and workmanship for the duration of ownership by the original retail purchaser.

Merchandise must be shipped prepaid with a copy of proof of purchase to Escalade® Sports factory for examination to determine if the basketball system needs to be repaired or replaced. Any labor costs, travel expenses and any other changes involved in the removal, installation or replacement of the defective/repared parts from/to your Goalrilla™ System will be the purchaser's responsibility. Shipping charges for replaced or warranted merchandise sent back to the customer from Escalade® Sports factory must be prepaid by the customer in advance. If not, the replacement shipment will be sent out collect.

Escalade® Sports reserves the right to examine photographs or physical evidence of merchandise claimed to be defective, and to recover said merchandise, prior to authorization of warranty claims. A "Returned Goods Authorization" number may be required, please call for details prior to the return of any photographs or merchandise.

This limited lifetime warranty is expressly in lieu of all warranties, expressed or implied, including warranties of merchantability or fitness for use. Escalade® Sports does not assume or authorize any person or representative to assume for us, any other liability in connection with the sale of our products.

The remedy of repair or replacement stated above is Escalade® Sports exclusive remedy. Escalade® Sports will not be liable for any other damages or expenses which may incur, including but not limited to incidental or consequential damages. Escalade® Sports assumes no other obligations or liability on the part of the purchaser, and Escalade® Sports neither assumes nor authorizes any other person to assume for it any other liability in connection with the goods sold.

This warranty shall not apply in any manner to parts or accessories not manufactured by Escalade® Sports.

NOT COVERED BY THIS WARRANTY

- Merchandise not intended to be in places of public assembly, such as, but not limited to, schools, parks, public or private recreational facilities.
- Any merchandise subjected to Non-residential abuse, negligence, improper installation, vandalism, acts of God, alteration of product, or any other events beyond the control of Escalade® Sports.
- Paint or rusted parts. If rust should appear, remove loose paint, sand lightly, primer and paint with exterior flat matte finish enamel paint.
- Rims are not warranted for any defects other than workmanship. Torn back plates, damaged springs, bent rings, damaged eyebolts, and torn or distorted rim supports result from hanging on the rim and are not warranted.
- Shipping charges both ways. Note: Any merchandise shipped to Escalade® Sports collect will be refused.
- Dealer service charges, labor charges and travel expenses associated with replacement of repair of warranty item.

WARRANTY DISCLAIMERS: ANY IMPLIED WARRANTIES ARISING OUT OF THIS SALE, INCLUDING BUT NOT LIMITED TO THE IMPLIED WARRANTIES OF MERCHANTABILITY AND FITNESS FOR A PARTICULAR PURPOSE, ARE LIMITED IN DURATION. ESCALADE® SPORTS SHALL NOT BE LIABLE FOR LOSS OF USE OF THE PRODUCT OR OTHER CONSEQUENTIAL OR INCIDENTAL COSTS. EXPENSES OR DAMAGES INCURRED BY THE CONSUMER OF ANY OTHER USE.

Some states do not allow the exclusion or limitation of implied warranties or consequential or incidental damages, so the above limitations or exclusions may not apply to you.

LEGAL REMEDIES: This warranty gives you specific legal rights, and you may also have other rights which may vary from state to state.

WARRANTY GUIDELINES IS REQUIRED FOR ALL WARRANTY CLAIMS

1. Proof of Purchase (original retail purchaser) is required for all warranty claims.
2. Call or write Escalade® Sports to receive a Return Authorization # and determine specific needs.
Phone: 1-888-USA-GOAL / Warranty Dept.
Or Write Escalade® Sports at: Escalade® Sports - P.O. Box 889, Evansville, IN 47706 - Attn: Warranty Dept.
Or E-mail us at: customerservice@escaladesports.com

B3222W-1 AND B3010W-1 PARTS LIST

Key#	Part #	Description	Qty.
1	3M-8926-00	Pole Pad -Universal	1
2	1A-7922-01	Post Assembly	1
3	2B-6093-10	½" Flat Washer	14
4		NOT USED	
5	3M-6245-01	½ X 1-1/4" Plastic Washer	22
6R	1A-7672-01	Upper Board Arm (Right Hand)	1
6L	1A-7673-01	Upper Board Arm (Left Hand)	1
7	1B-6222-10	1/2-13 X 10" Hex Bolt-Grade 5	1
8	1B-6218-10	1/2-13 X 11" Hex Bolt-Grade 5	3
9	3M-6274-00	1" X 2" Tube Plug	2
10	3M-6834-00	1 9/16" X3 5/32 " Tube Plug	4
11	1A-7651-00	Lower Board Arm	1
12	1B-6999-00	#10 X 1 ¾" Phil. Hex Head Screw	7
13	3M-8939-00	Actuator Cap	1
14	8S-6566-01	Pivot Tube	1
15	2M-6160-00	Actuator Sleeve	1
16	4A-7081-00	Actuator	1
17	4L-8126-00	Height Decal	1
18	2B-6094-10	½" Split Lock Washer	2
19	1B-6215-10	1/2-13 x 1" Hex Bolt	2
20	1B-6944-10	1/2-13 X 1 3/4" Hex Bolt	2
21		NOT USED	
22	7B-6439-00	Step Bushing -Two way	2
23	6A-7480-00	Backboard Assembly - 38" X 60"	1
24	2B-6238-10	3/8-16 Locknut	8
25	1B-6936-10	3/8-16 X 1 1/4" Hex Bolt - Grade 5	4
26	2B-6289-10	3/8 X 19mm Flat Washer	12
27		NOT USED	
28	6A-6328-02	Goal Assembly	1
29	1B-6782-10	3/8-16 X 1-3/4" Carriage Bolt	4
30	3F-6010-00	Net	1
31	2S-6421-00	Rim Cover Plate	1
32	1B-6238-01	#8 x ½" Thread Forming Screw	4
33	7B-6391-01	Step Bushing	2
34	3M-9040-01	5/8" Thread Protector	4
35	2B-6097-10	5/8-11 Hex Nut	12
36	2B-6099-10	5/8" Split Lockwasher	4
37	2B-6834-10	5/8" SAE Flat Washer	8
38	2S-6494-00	Anchor Plate	1
39	2B-6096-03	5/8-11 X 18 "J" Bolt	4
40	1S-6152-00	#3 X 40" Rebar	4
41	7B-6255-00	Pull Pin	1
42	4A-6550-00	Actuator Handle	1
43	2L-7249-04	Owners Manual	1
44	3M-8943-00	Backboard Pad- Right	1
45	3M-8944-00	Backboard Pad- Left	1
46	3M-6838-00	Pole Cap	1
47	3M-9091-00	Pole Hole Plug	3
48	2S-6794-00	Post Ear	2
49	2B-6242-10	1/2-13 Nylon Locknut (thin)	10
50	1B-6781-10	1/2-13 X 2 1/4" Hex Bolt	4
51	2B-6302-10	14mm ID X 28mm OD Washer	8
52	1A-7671-01	CV60 Cross Brace for Upper Arms	1
53	3M-8945-00	Backboard Pad- Middle	1

