

M20SP410 NECK FINISH
 DIMENSIONS APPLY TO AVERAGE OF
 HIGH & LOW POINTS ON DIA'S
 MIN. WALL .012
 DIMENSIONS APPLY AFTER DECORATING

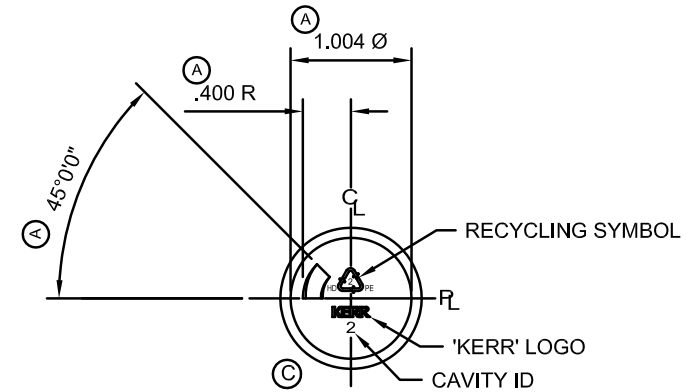
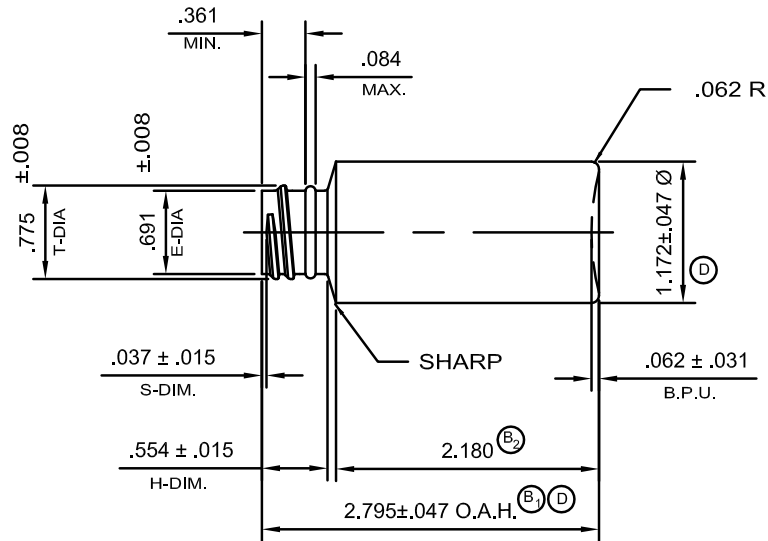
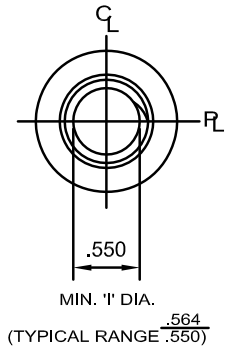

UNLESS OTHERWISE SPECIFIED, DECIMALS $\pm .047$ "		
MATERIAL	H.D.P.E.	
CAPACITY OVERFLOW	36.5cc ± 1.5 cc	1.234 FL. OZ.
V.A.F.P.		FL. OZ.
EST. WT.	.194	FL. OZ.
DISPLACEMENT	5.5 GRS + 5 GR	1.428 FL. OZ.

DISCLAIMER

THIS INFORMATION IS PROVIDED AS A GENERAL GUIDE, INCLUDING DIMENSIONS. IT IS THE CUSTOMER'S RESPONSIBILITIES TO SELECT THE PROPER CONTAINER FOR PRODUCT AND APPLICATION COMPATIBILITY.

DISTRIBUTED BY:



REF NO.:

DWG30687

DESCRIPTION:

1 oz HDPE Cylinder, 20-410